

10/17/2014 11:02:14 AM - P:\IER\11740\200-11740-10003\CAD\SHEETFILES\TREATMENT PLANT\WTP E 9603 LOW VOLTAGE ONE-LINE.DWG - CALZARETTA, TIMOTHY

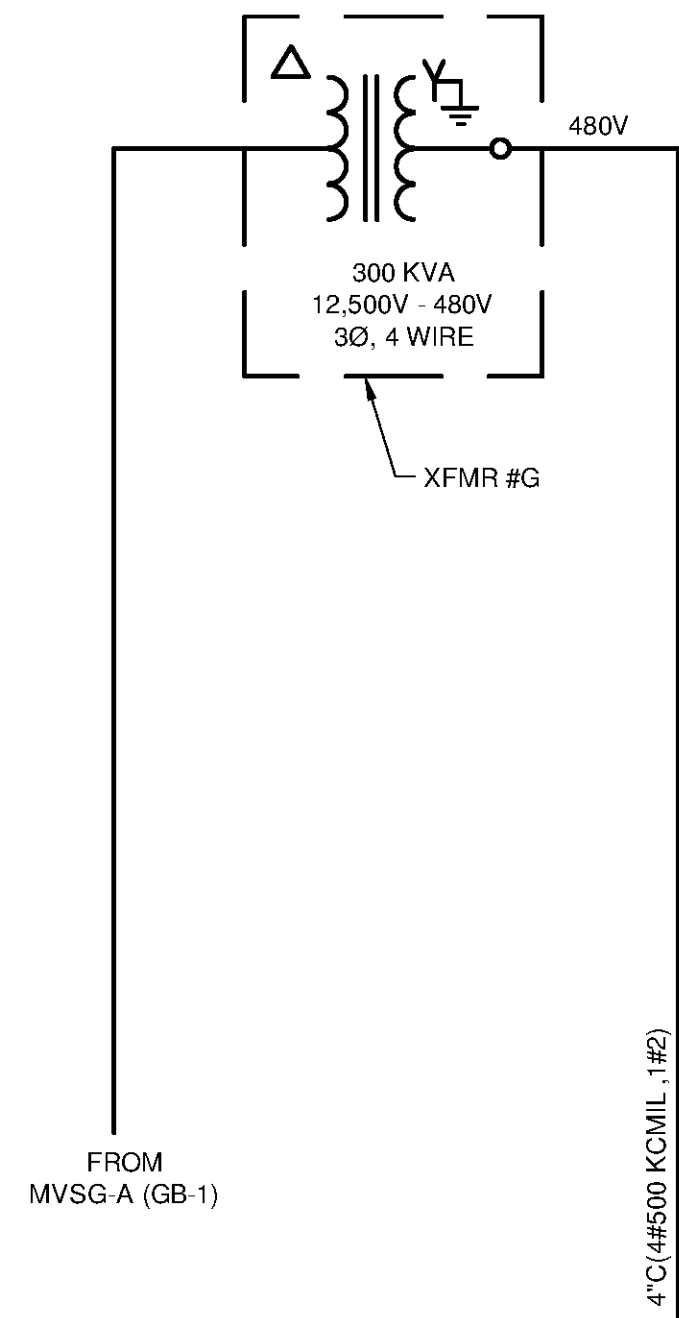

4" C(4#500 KCWIL, #2)

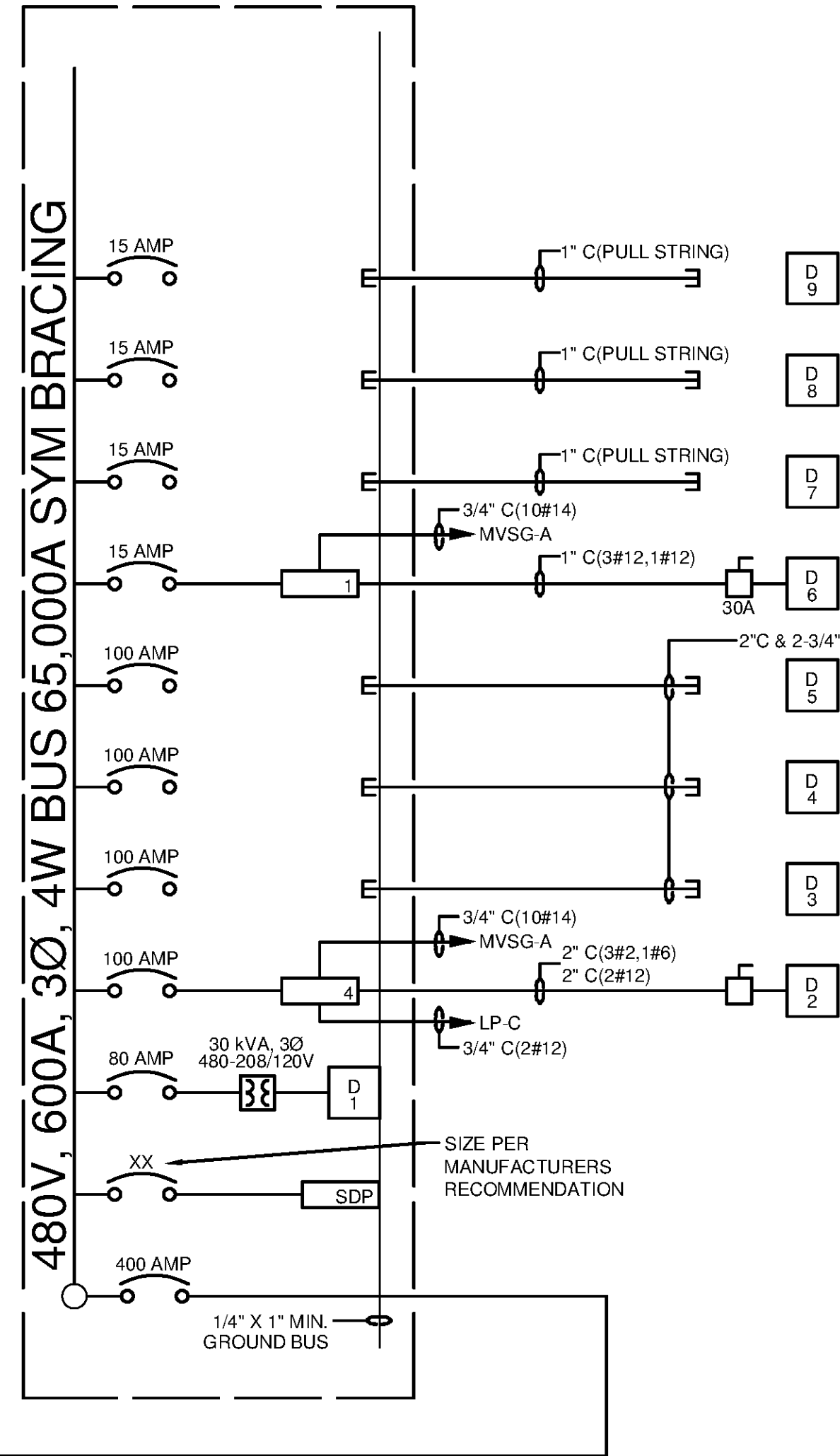

MCC D ONE-LINE
SCALE: N/A

- 5 HP INLINE COOLING WATER PUMP #4 (FUTURE)
- 5 HP INLINE COOLING WATER PUMP #3 (FUTURE)
- 5 HP INLINE COOLING WATER PUMP #2 (FUTURE)
- 5 HP INLINE COOLING WATER PUMP #1
- 50 HP VERTICAL RADIATOR FAN#4 (FUTURE)
- 50 HP VERTICAL RADIATOR FAN#3 (FUTURE)
- 50 HP VERTICAL RADIATOR FAN#2 (FUTURE)
- 50 HP VERTICAL RADIATOR FAN#1
- LP-D (30 KVA) LIGHTING PANEL

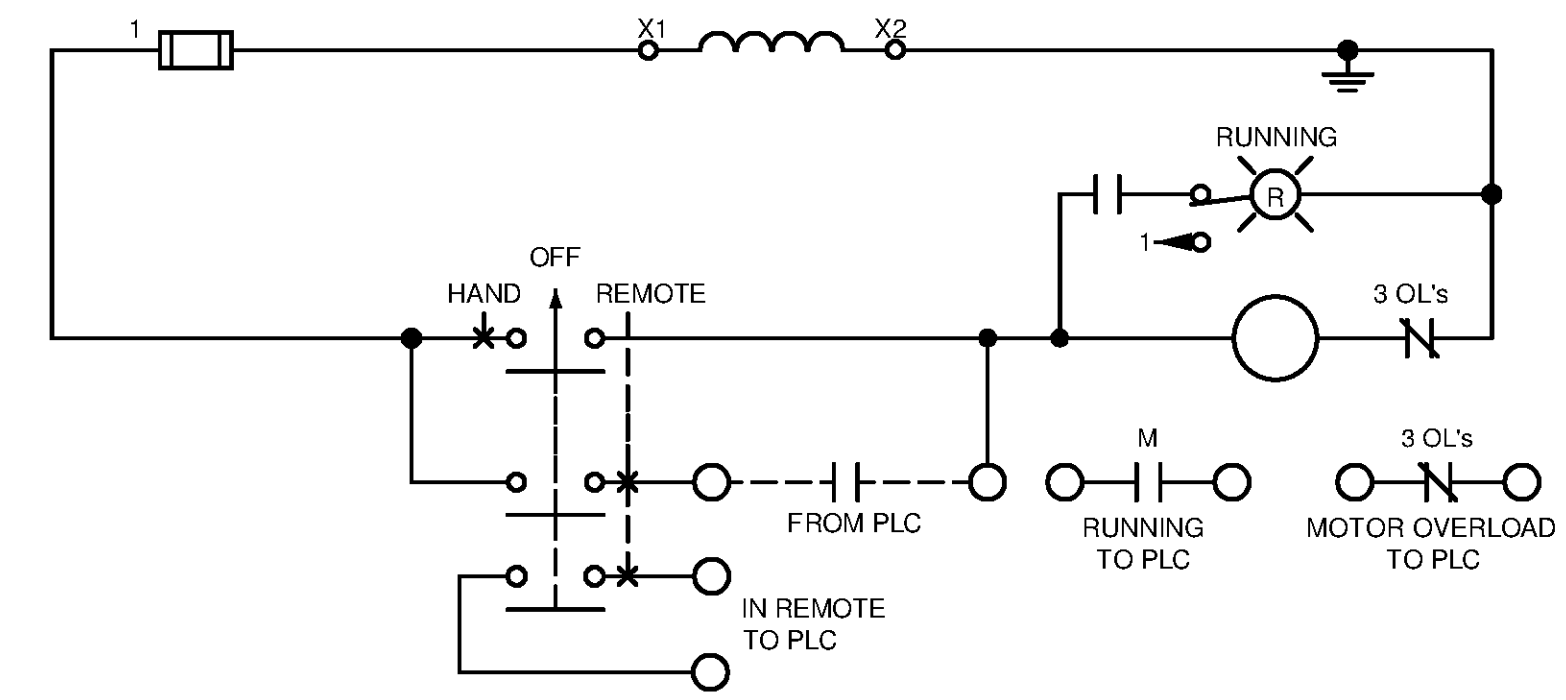

COOLING WATER PUMP WIRING DIAGRAM TYP. GENSETS 1-4
SCALE: N/A

NOTES:
1. CONTROLS AND MONITORING TO BE PROVIDED BY CONTROLLER IN MVSG-A.

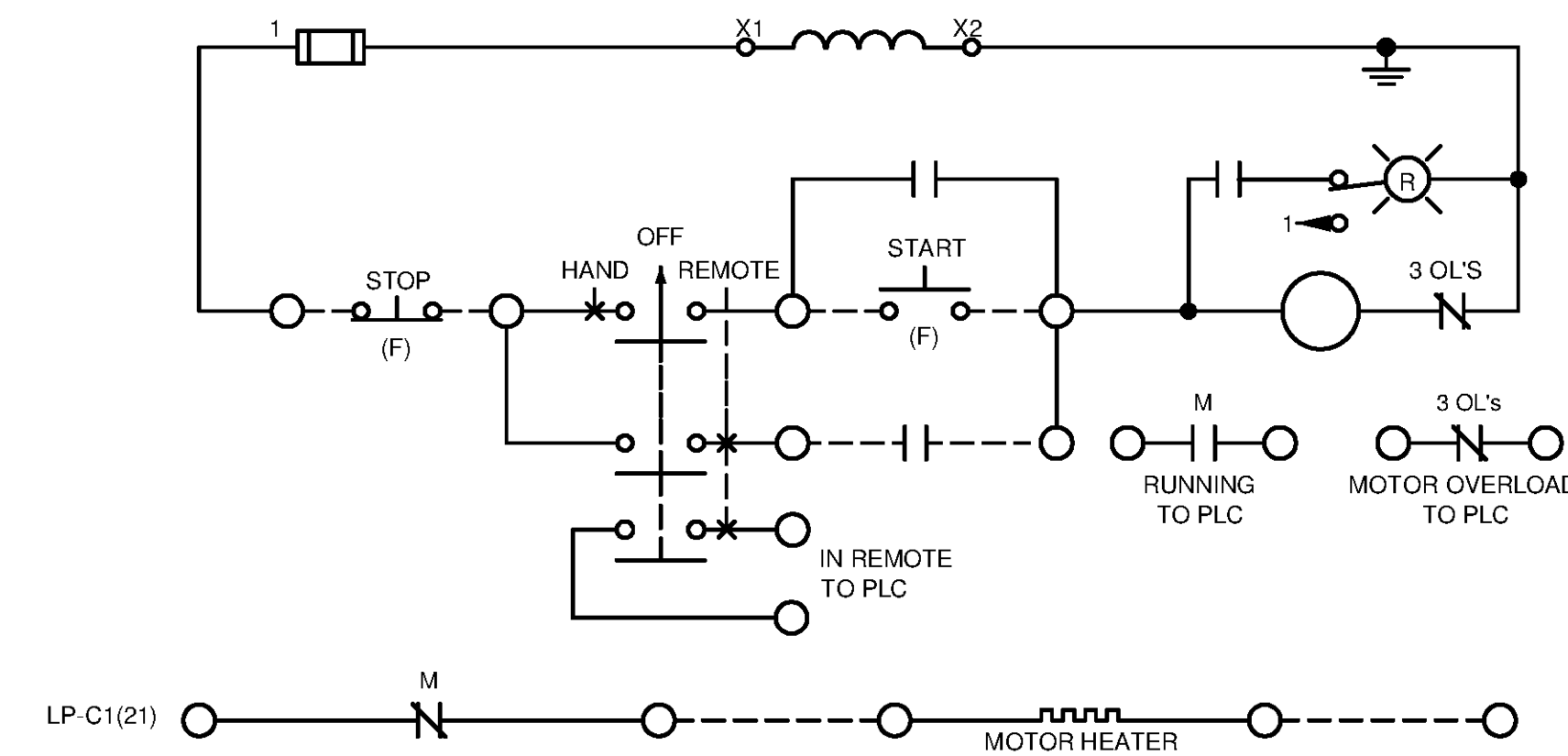

RADIATOR FAN WIRING DIAGRAM TYP. GENSETS 1-4
SCALE: N/A

NOTES:
1. CONTROLS AND MONITORING TO BE PROVIDED BY CONTROLLER IN MVSG-A.



www.tetrattech.com
101 QUALITY CIRCLE, SUITE 140
HUNTSVILLE, ALABAMA 35806
PHONE: (256) 424-4077 FAX: (256) 424-4097

BID SET

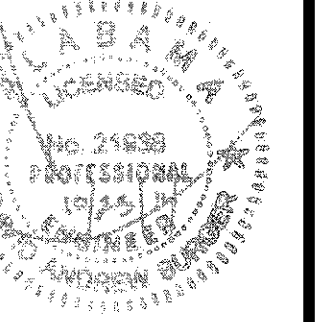

MARK	DATE	DESCRIPTION

HUNTSVILLE UTILITIES
SOUTHEAST WATER TREATMENT PLANT
LOW VOLTAGE ONE-LINE

Project No.: 200-11740-10003
Designed By: CSW
Drawn By: CSW
Checked By: DAB

E-8604

Copyright: Tetra Tech
Bar Measures 1 inch