

10/17/2014 3:50:32 PM P:\SERV\1740200-11740-10003\CAD\SHEETFILES\TREATMENT PLANT\WTP-D-950X STANDARD PROCESS DETAILS.DWG -EVANS, JON

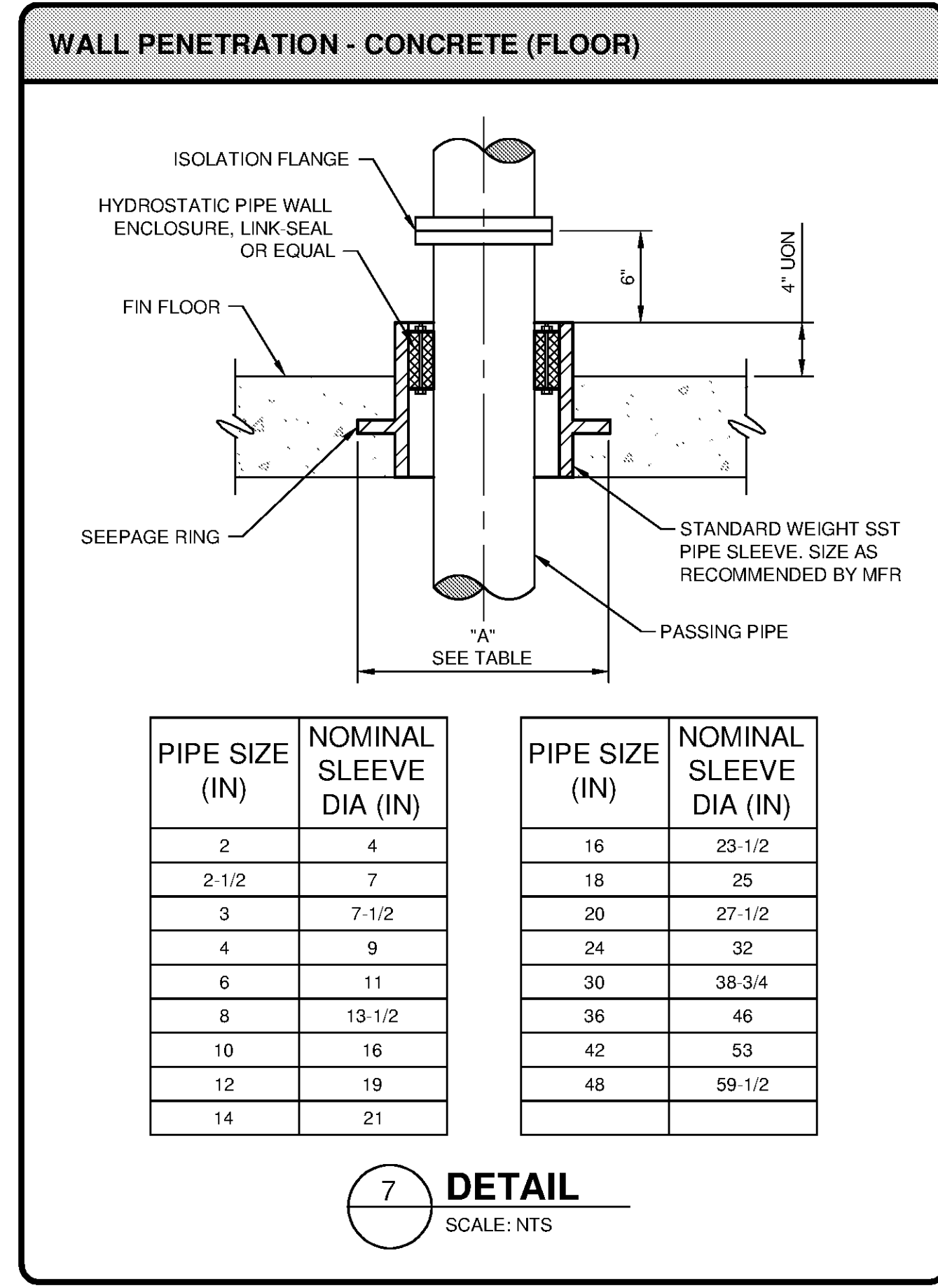
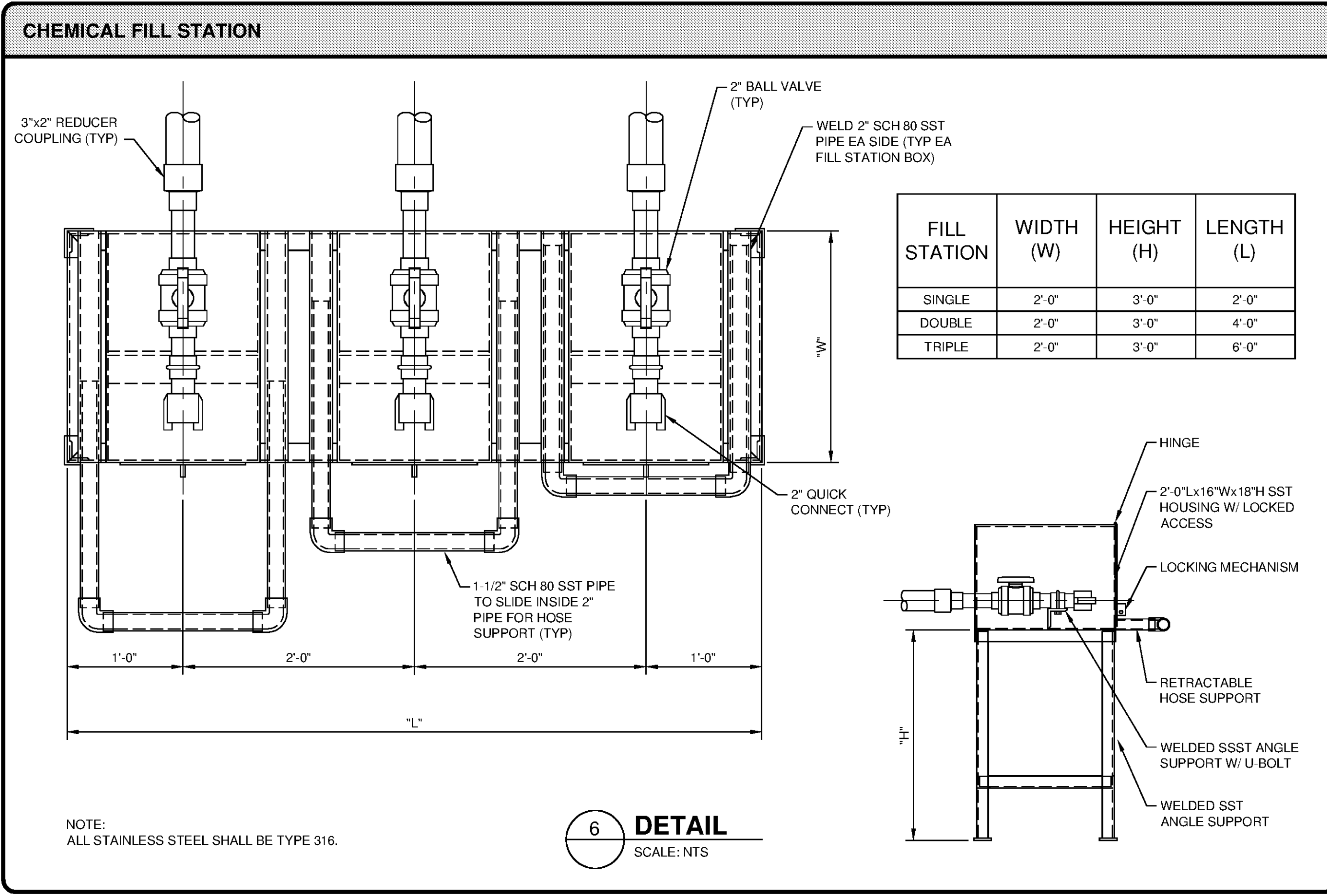
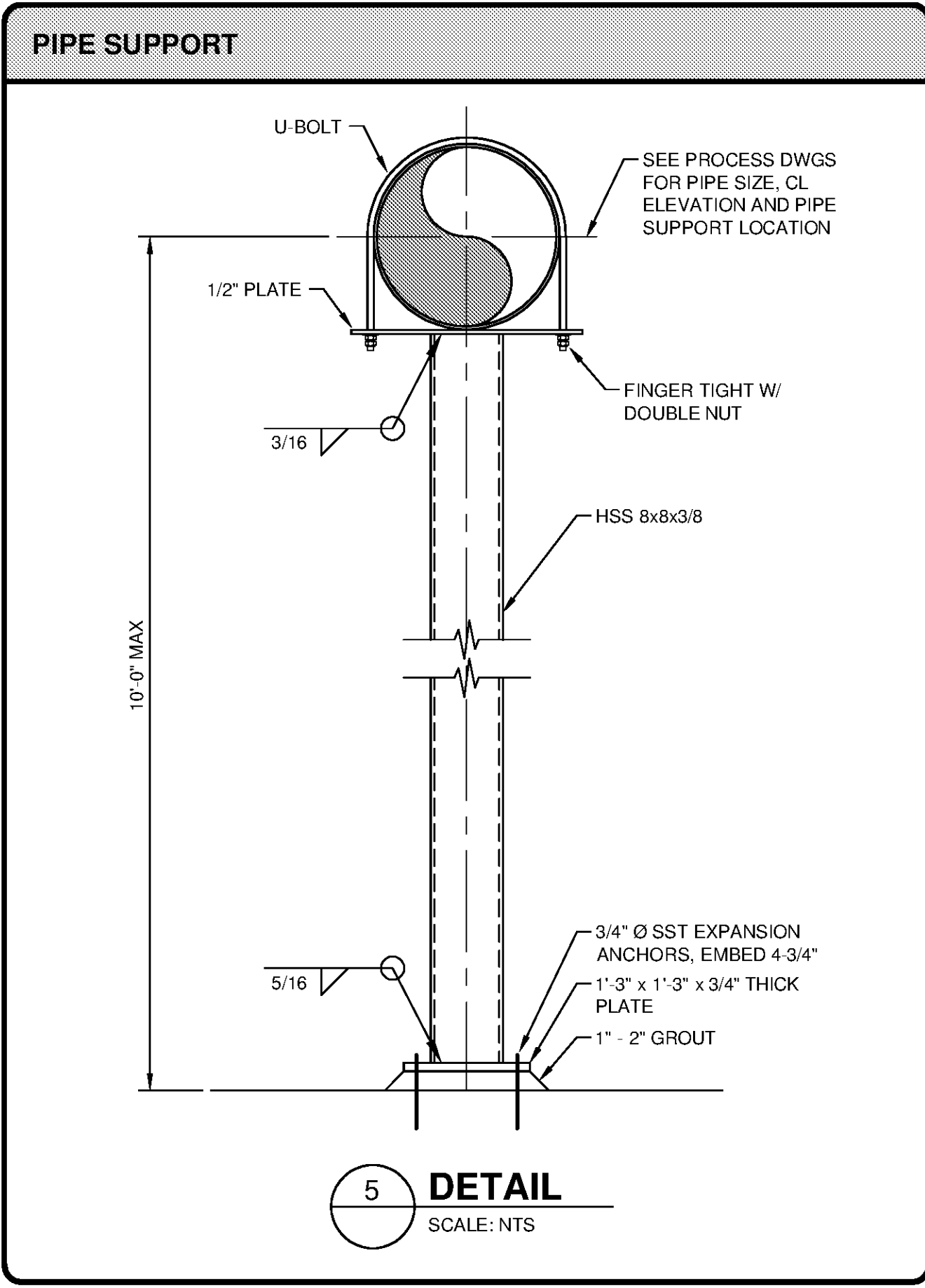
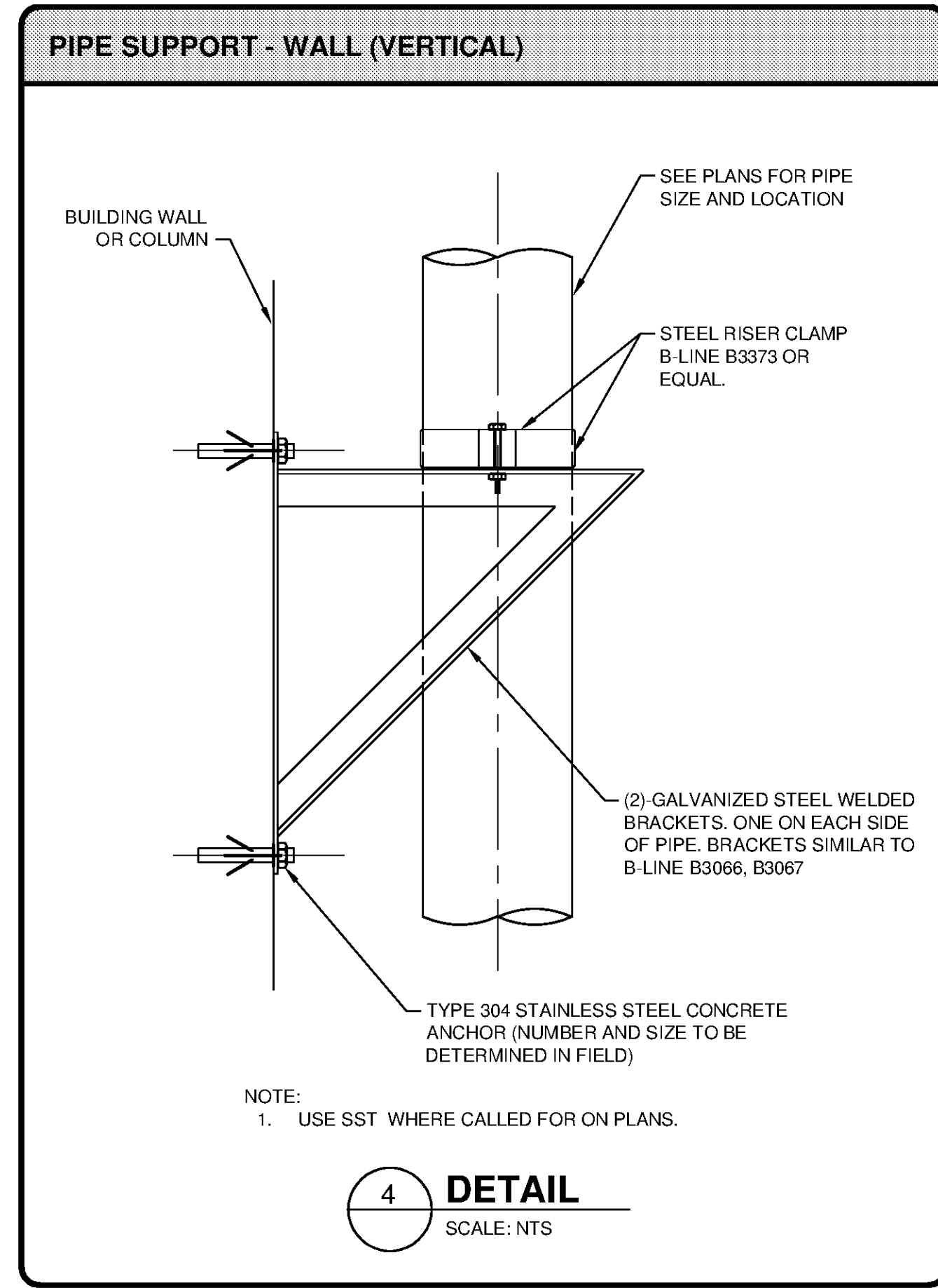
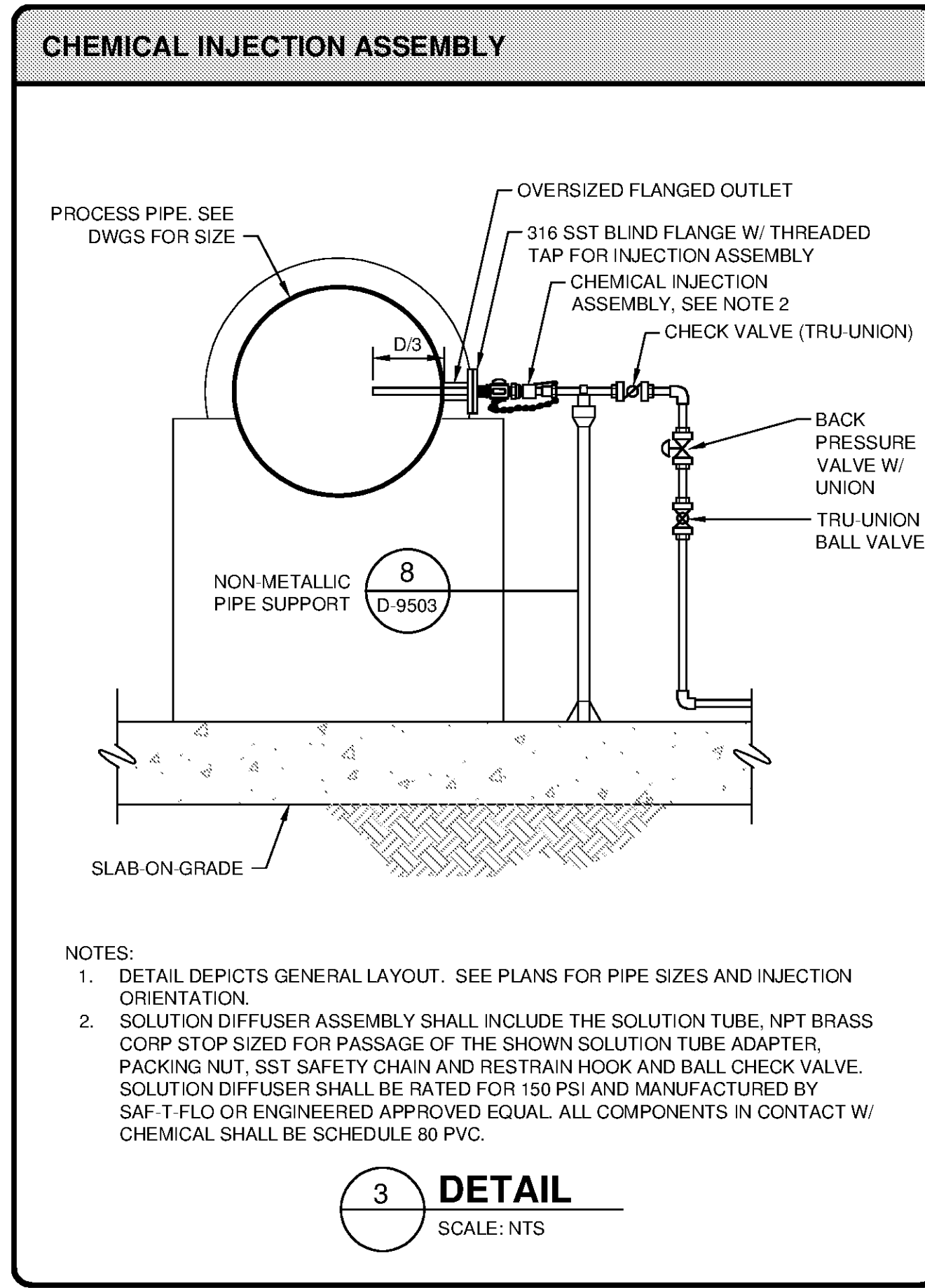
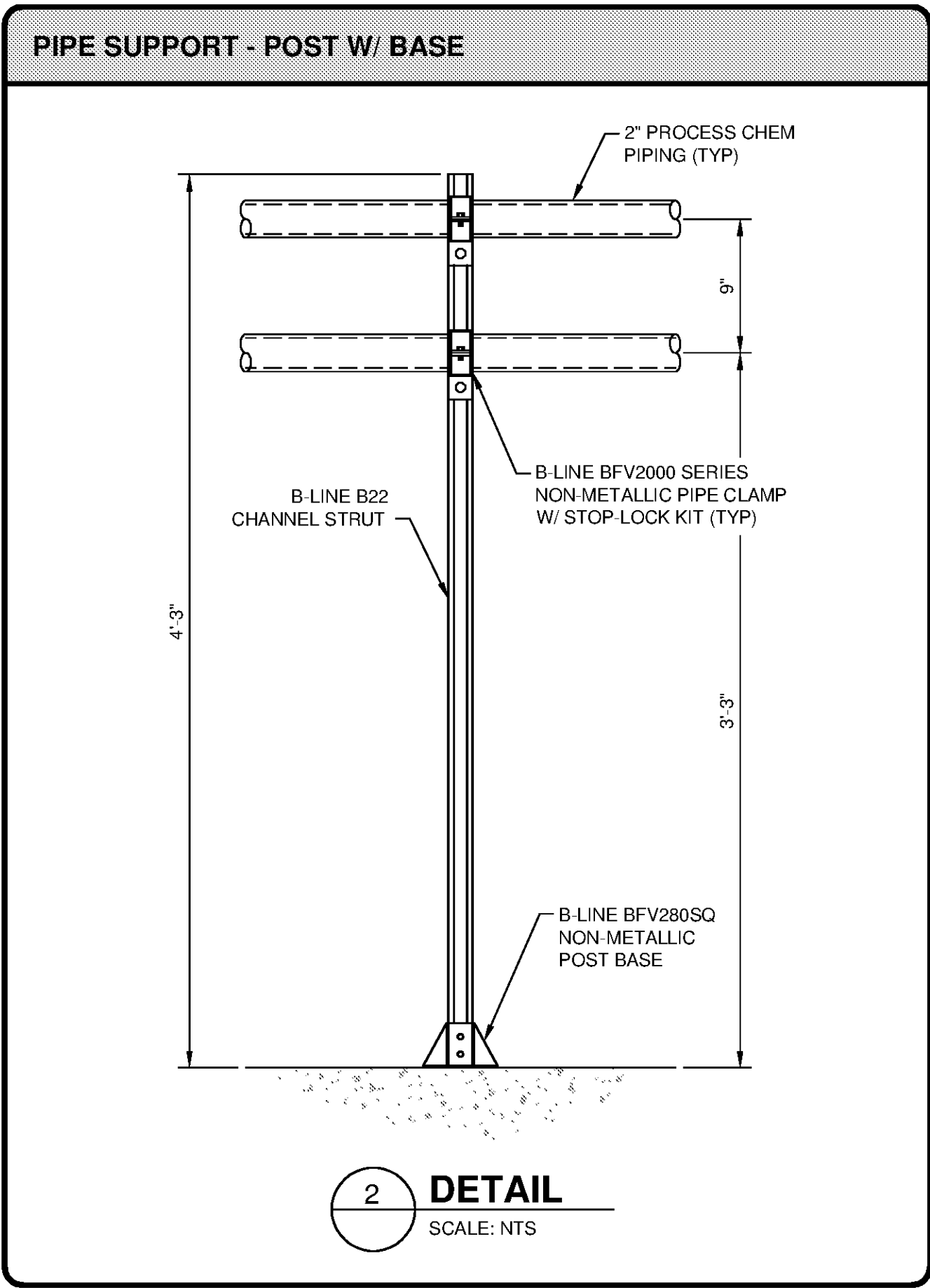
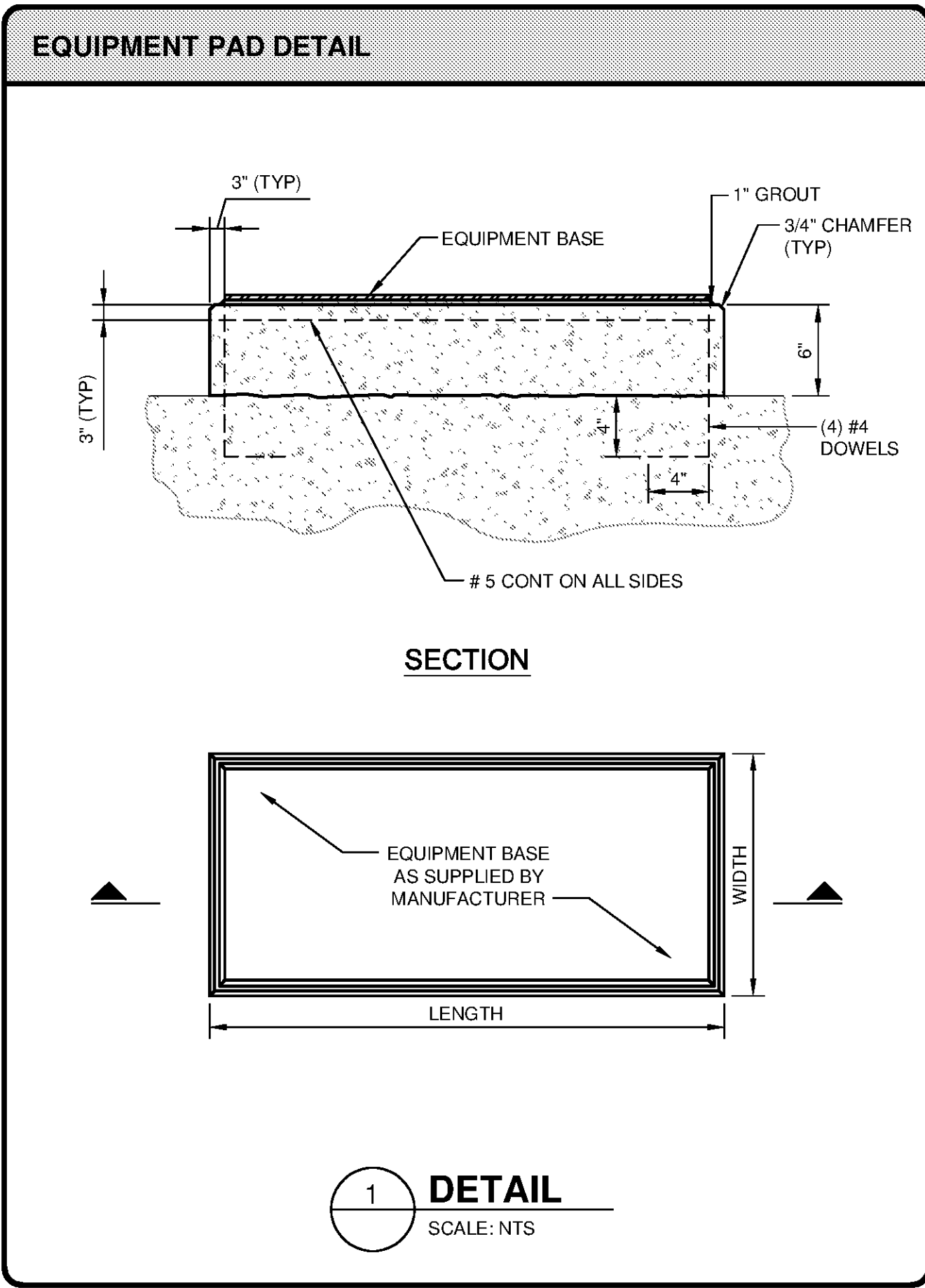

TETRA TECH

BID SET

HUNTSVILLE UTILITIES  
SOUTHEAST WATER TREATMENT PLANT

STANDARD  
PROCESS DETAILS

Project No.: 200-11740-10003  
Designed By: JEC  
Drawn By: JTE  
Checked By: JPT

D-9505

Copyright: Tetra Tech

Bar Measures 1 inch