

14 EXPANSION JOINT AT DECK
SCALE: 1 1/2" = 1'-0"

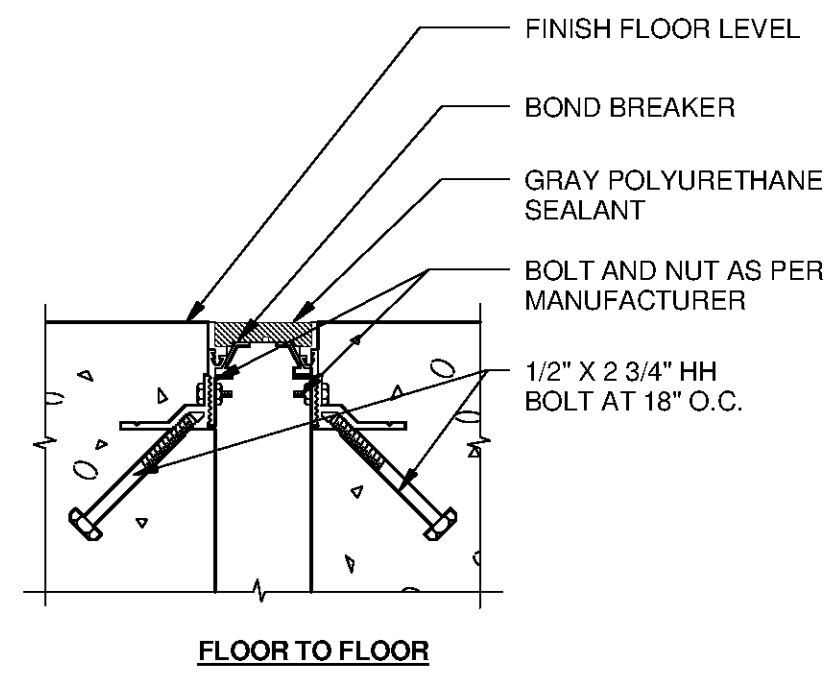

15 EXPANSION JOINT DETAIL AT BASIN
SCALE: 3" = 1'-0"

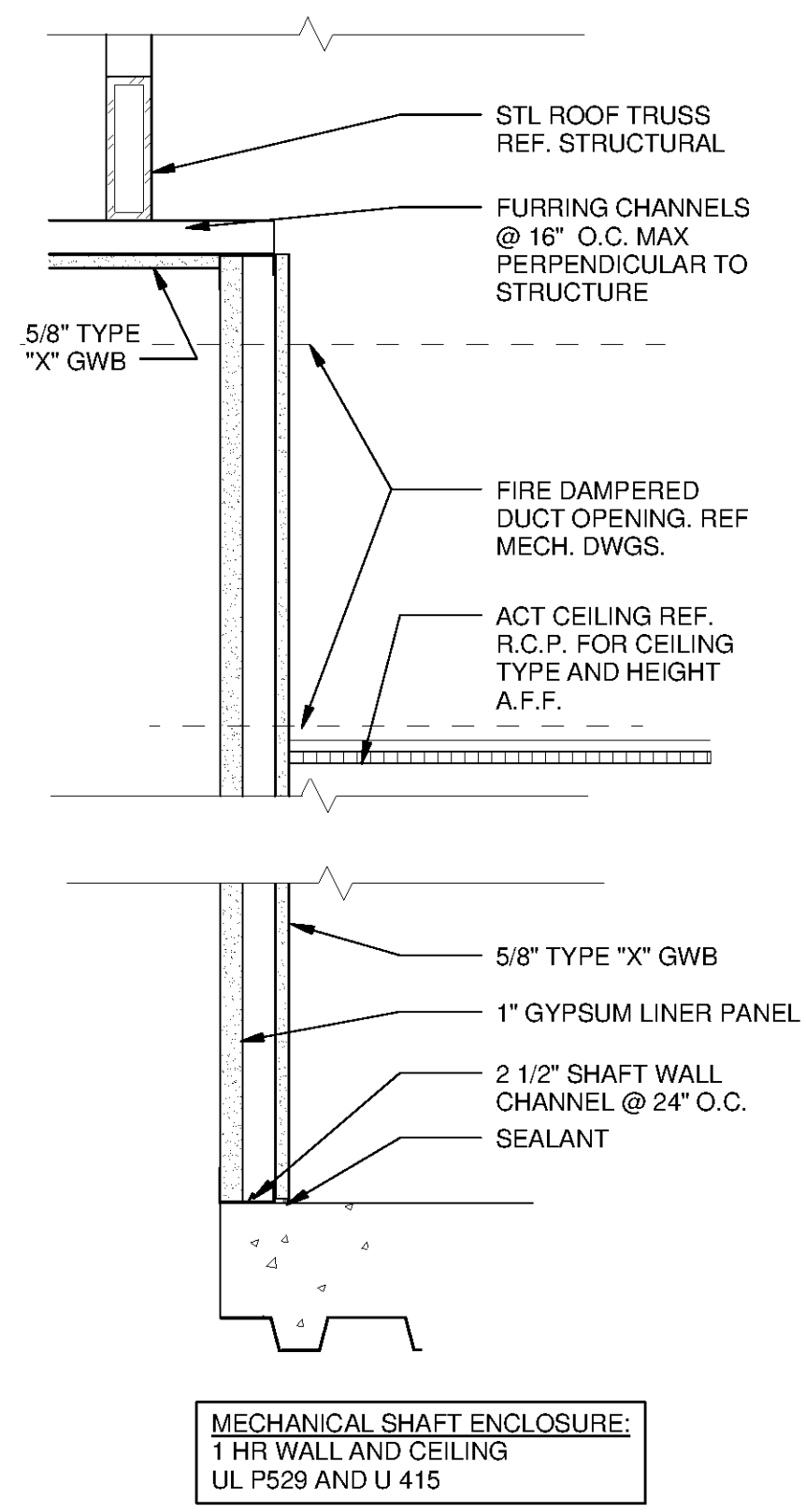

12 WALL TYPE 12
SCALE: 1 1/2" = 1'-0"

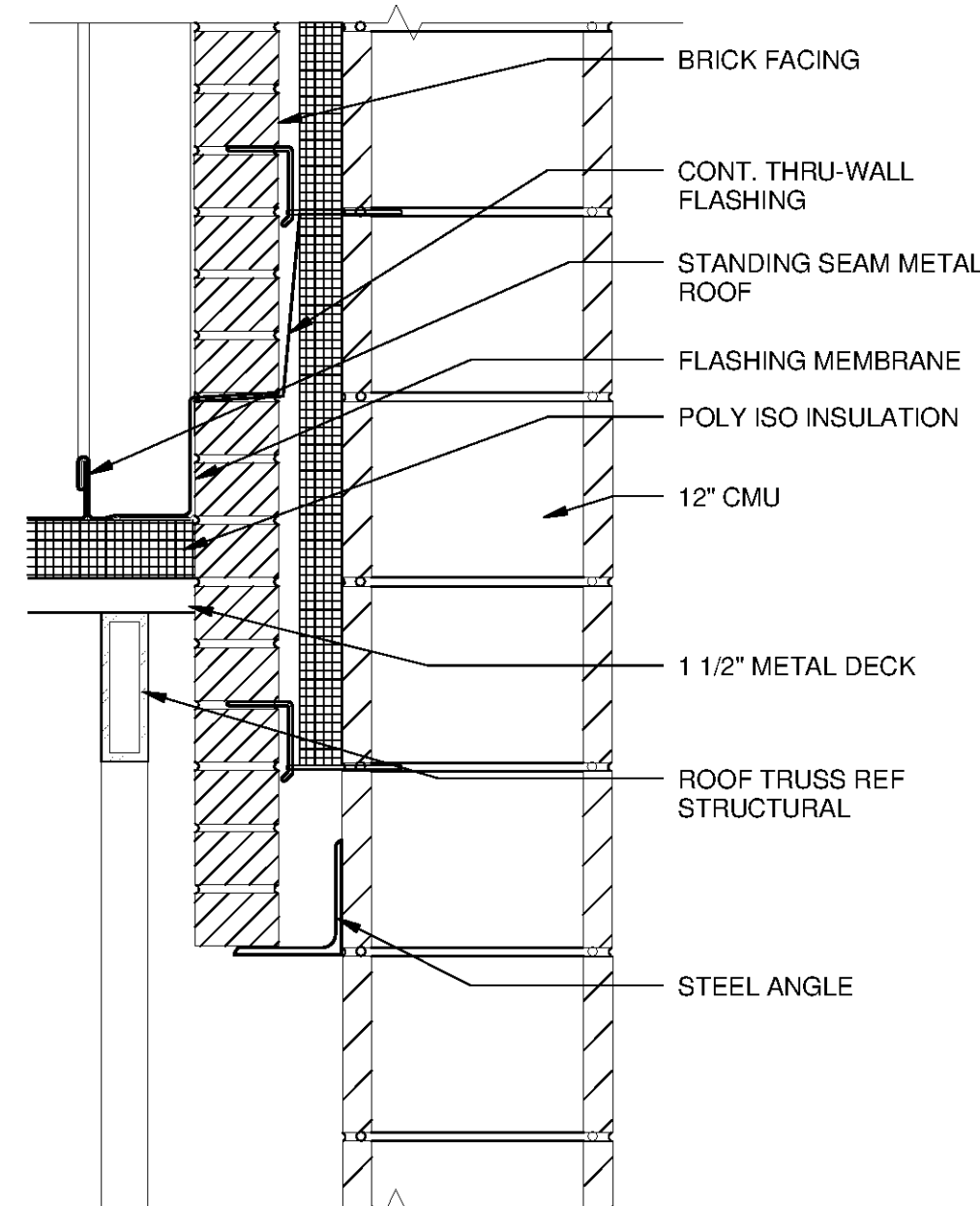

13 RAKE AT UPPER WALL
SCALE: 1 1/2" = 1'-0"

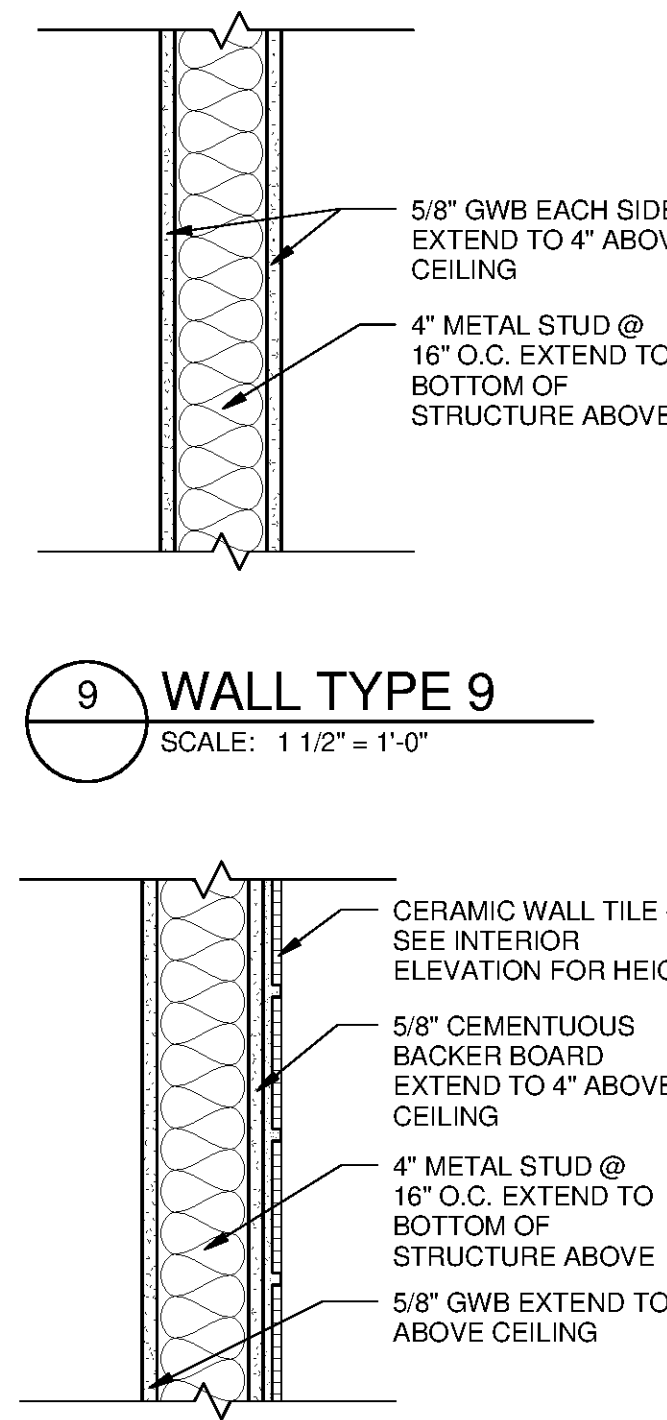

9 WALL TYPE 9
SCALE: 1 1/2" = 1'-0"

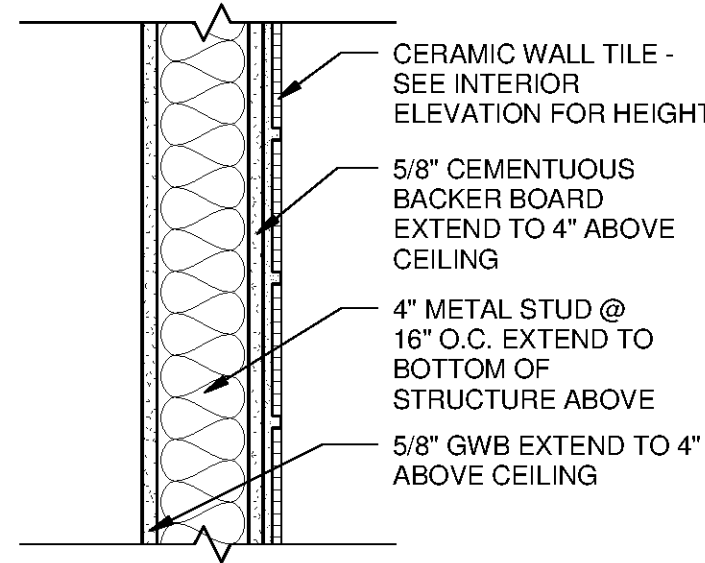

10 WALL TYPE 10
SCALE: 1 1/2" = 1'-0"

EXTERIOR WALL NOTE:

1. REFER TO STRUCTURAL AND ARCHITECTURAL DRAWINGS FOR FOOTING, FOUNDATION AND FLOOR SLAB DETAILS.
2. TOOL JOINTS FLUSH ON CAVITY SIDE OF CMU BACKUP WALL TO RECEIVE AIR INFILTRATION BARRIER.
3. CMU AND CLAY MASONRY SHALL BE FREE OF DEFECTS, TYPICAL.

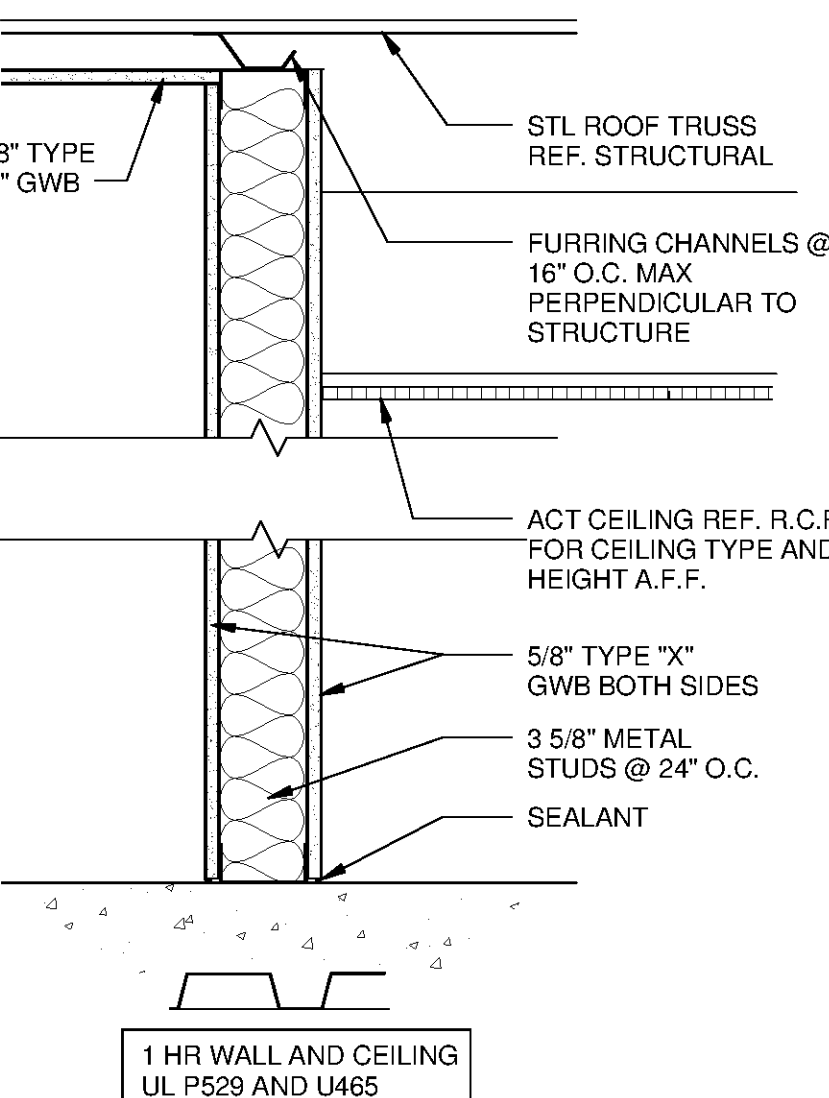

11 WALL TYPE 11
SCALE: 1 1/2" = 1'-0"

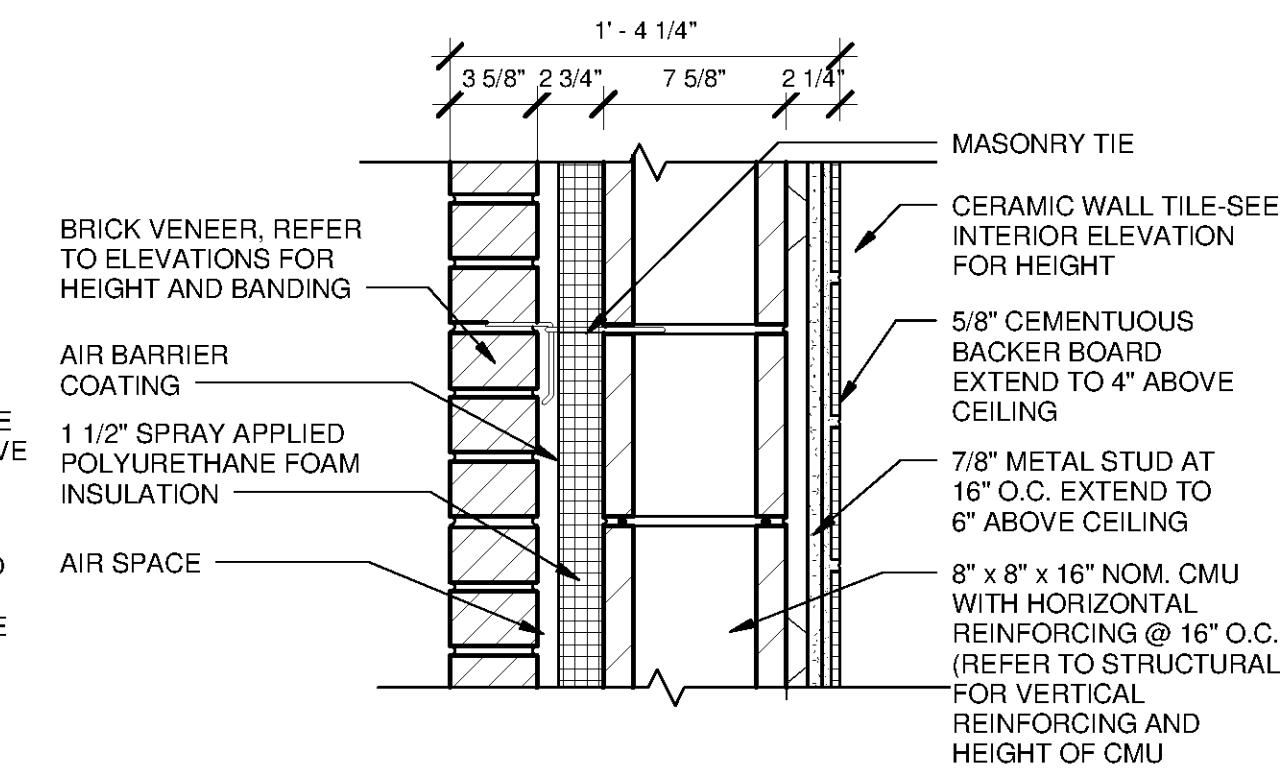

5 WALL TYPE 5
SCALE: 1 1/2" = 1'-0"

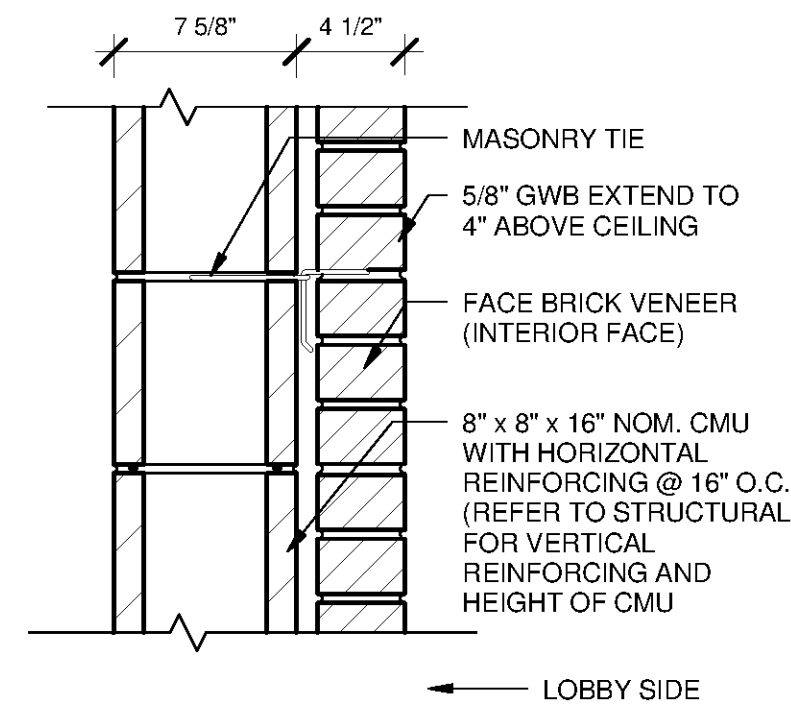

6 WALL TYPE 6
SCALE: 1 1/2" = 1'-0"

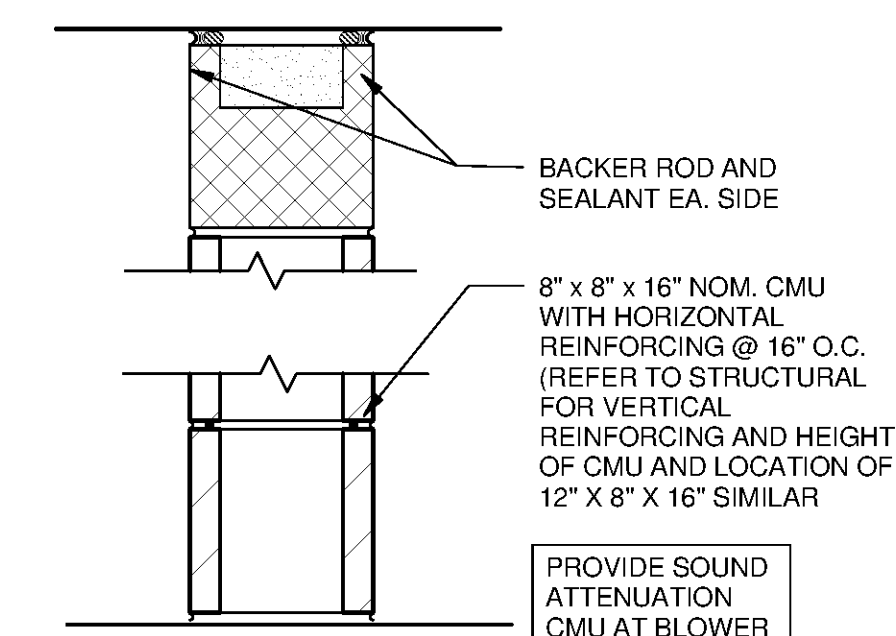

7 WALL TYPE 7
SCALE: 1 1/2" = 1'-0"

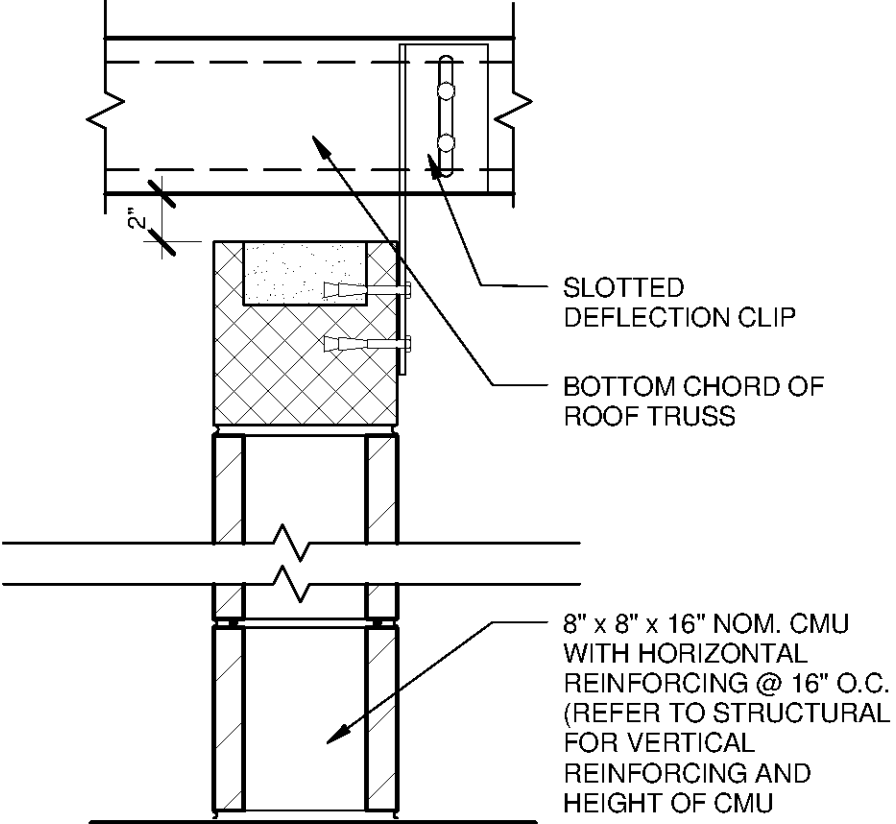

8 WALL TYPE 8
SCALE: 1 1/2" = 1'-0"

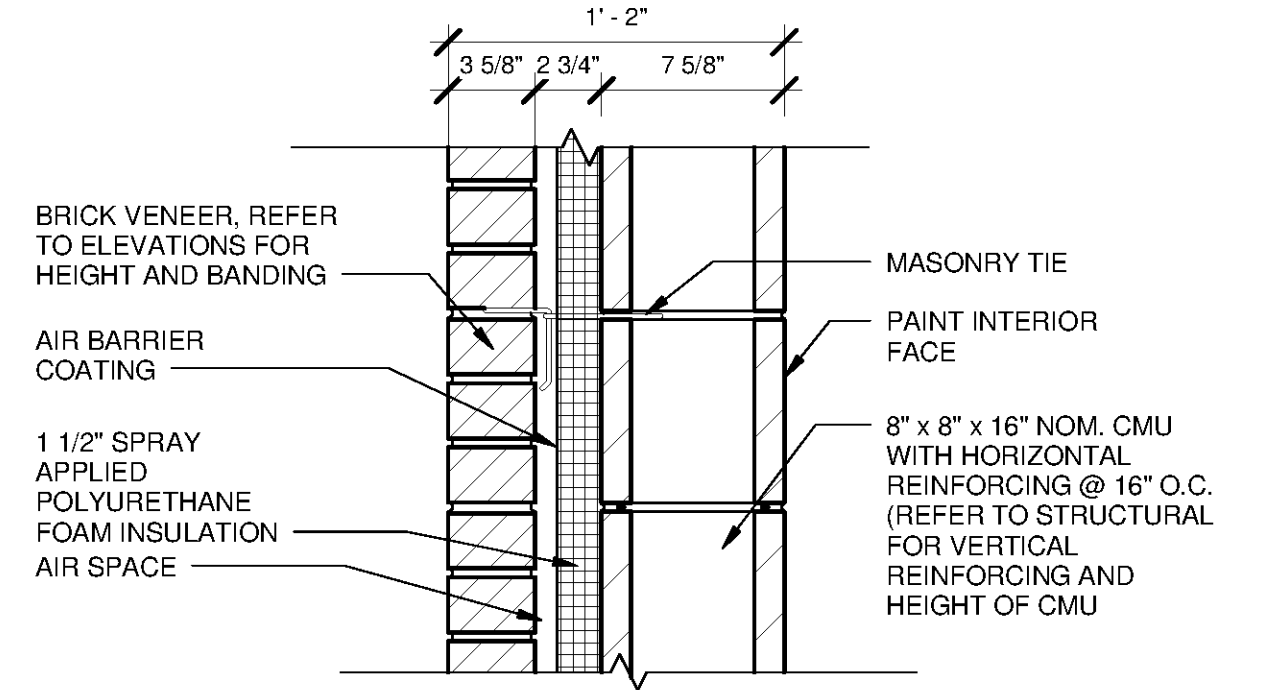

1 WALL TYPE 1
SCALE: 1 1/2" = 1'-0"

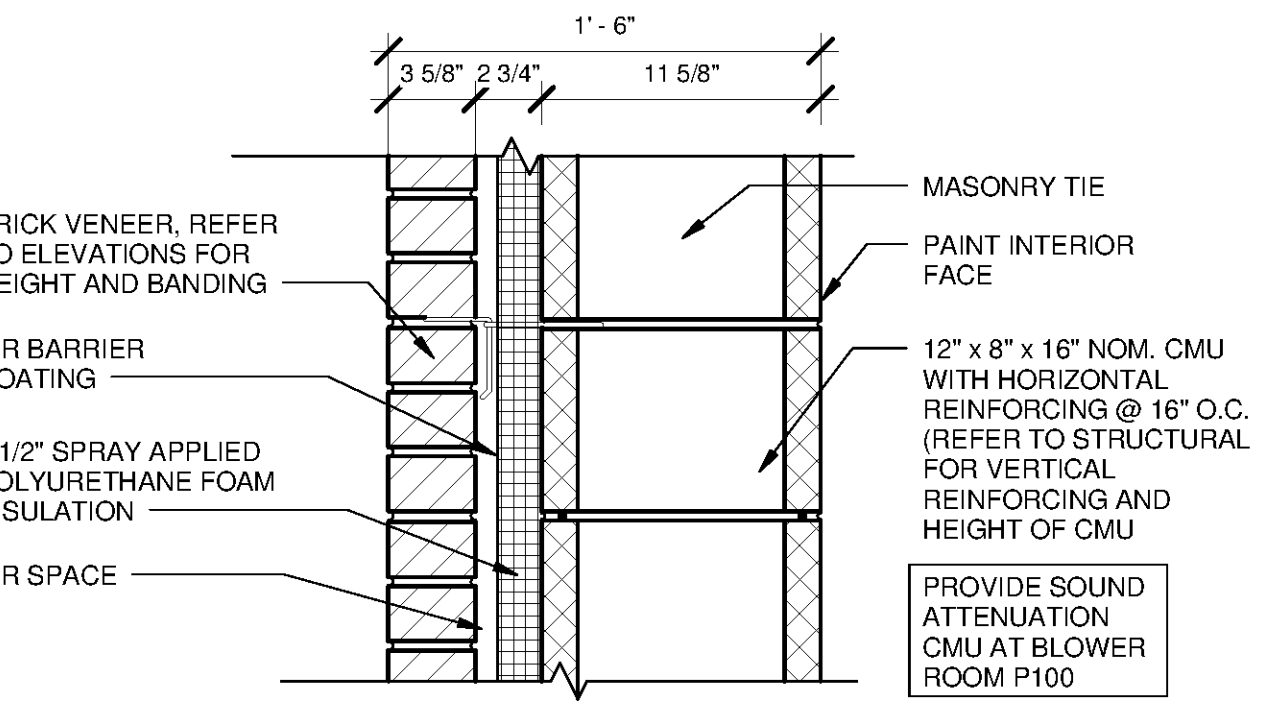

2 WALL TYPE 2
SCALE: 1 1/2" = 1'-0"

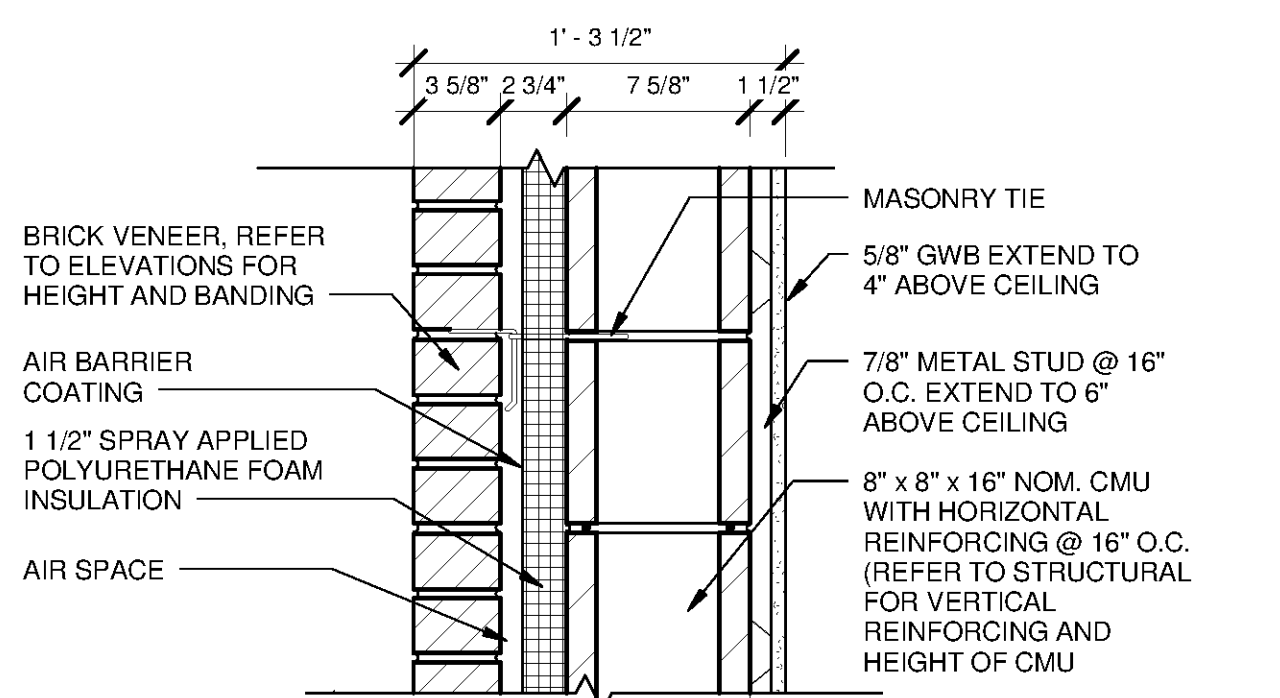

3 WALL TYPE 3
SCALE: 1 1/2" = 1'-0"

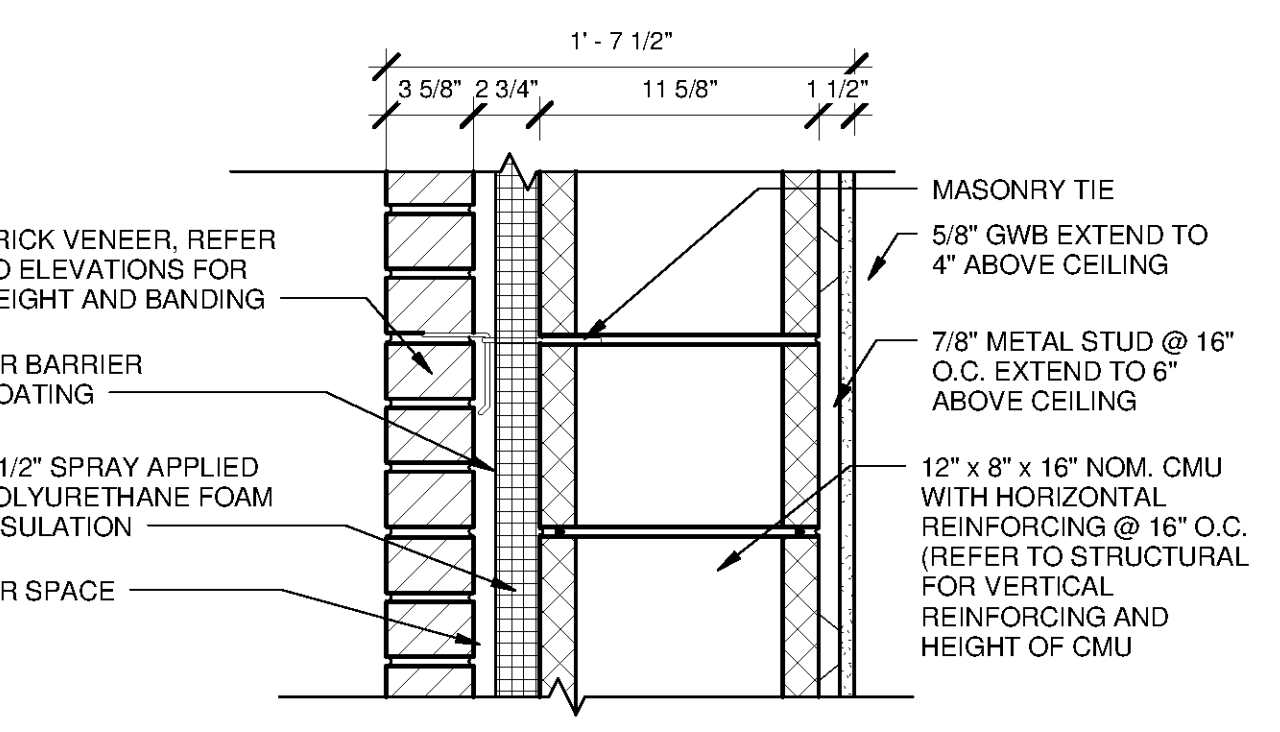

4 WALL TYPE 4
SCALE: 1 1/2" = 1'-0"



BID SET

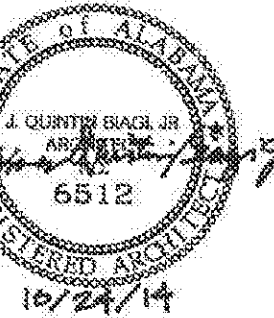

BY: _____
DESCRIPTION: _____
DATE: _____
MARK: _____

HUNTSVILLE UTILITIES
SOUTHEAST WATER TREATMENT PLANT
STANDARD
ARCHITECTURAL DETAILS

Project No.: 200-11740-10003
Designed By: Q.BIAGI
Drawn By: Q.BIAGI
Checked By: D.GALANTE

A-9503

Bar Measures 1 inch