

C:\Users\brent.fox\Documents\WTP-11740-S-GACBAC\_brent.fox.rvt 10/1/2014 4:19:55 PM

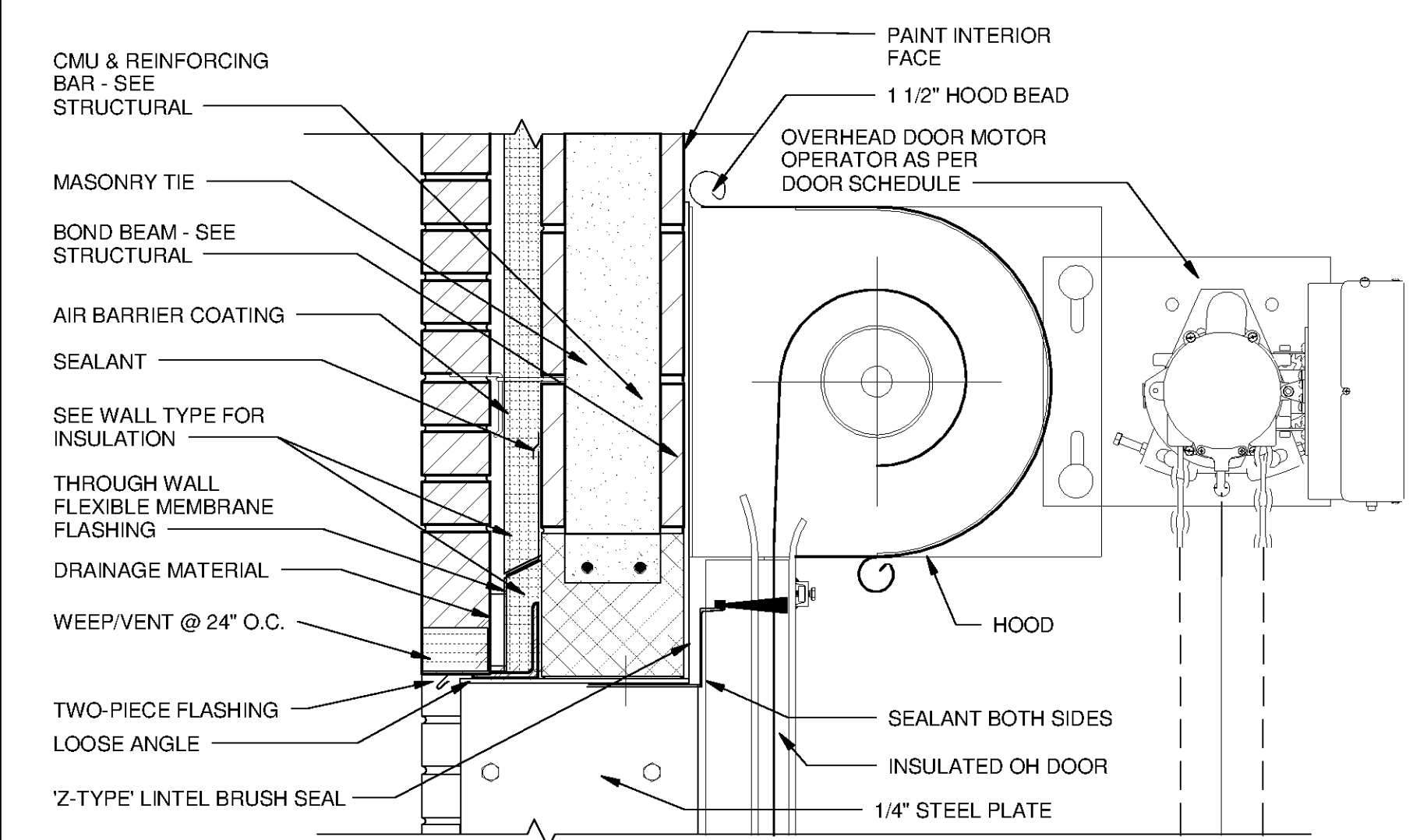

**12 DOOR HEAD TYPE OH.1**  
A-3302 SCALE: 1 1/2" = 1'-0"

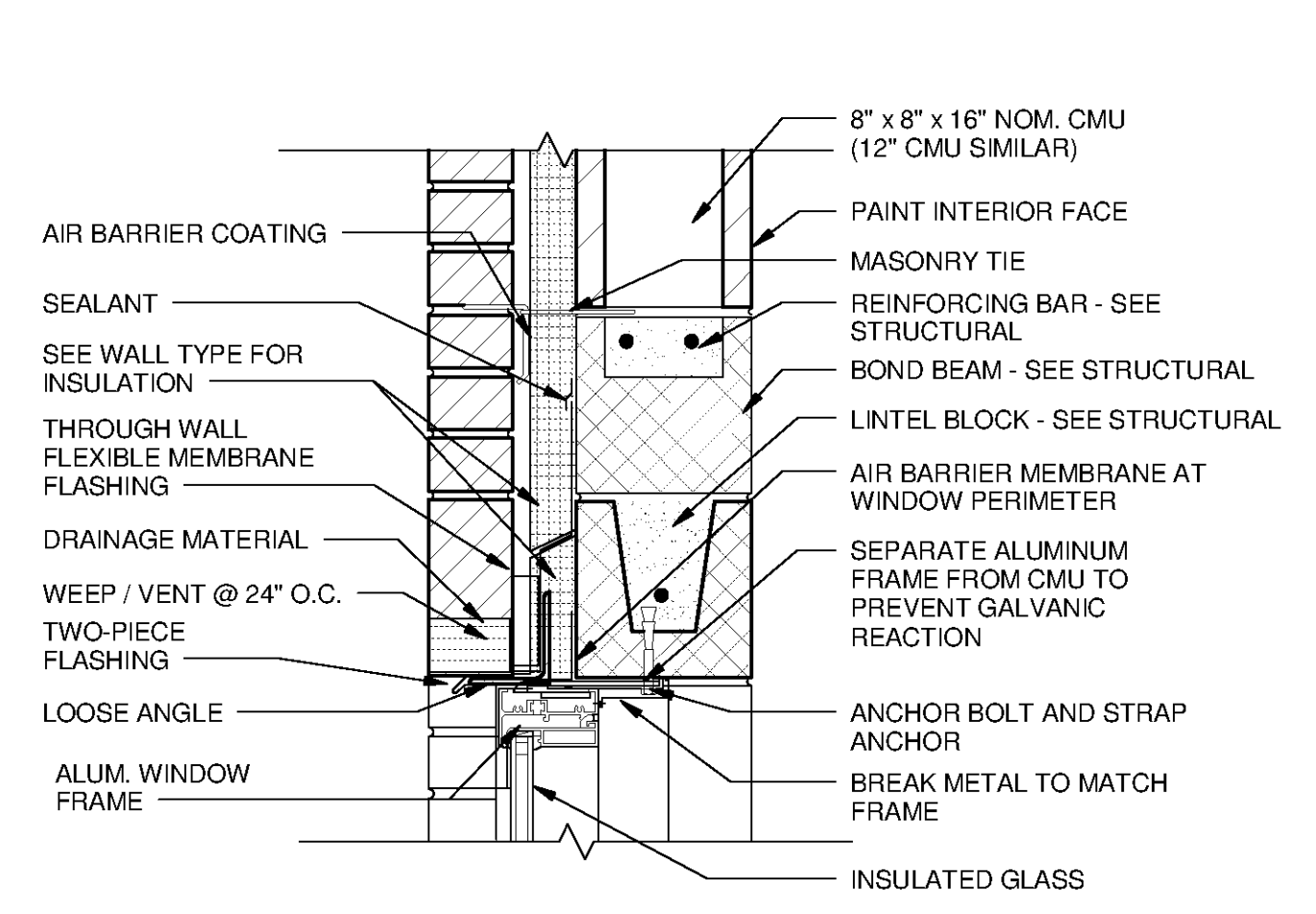

**7 WINDOW HEAD TYPE WH-A**  
SCALE: 1 1/2" = 1'-0"

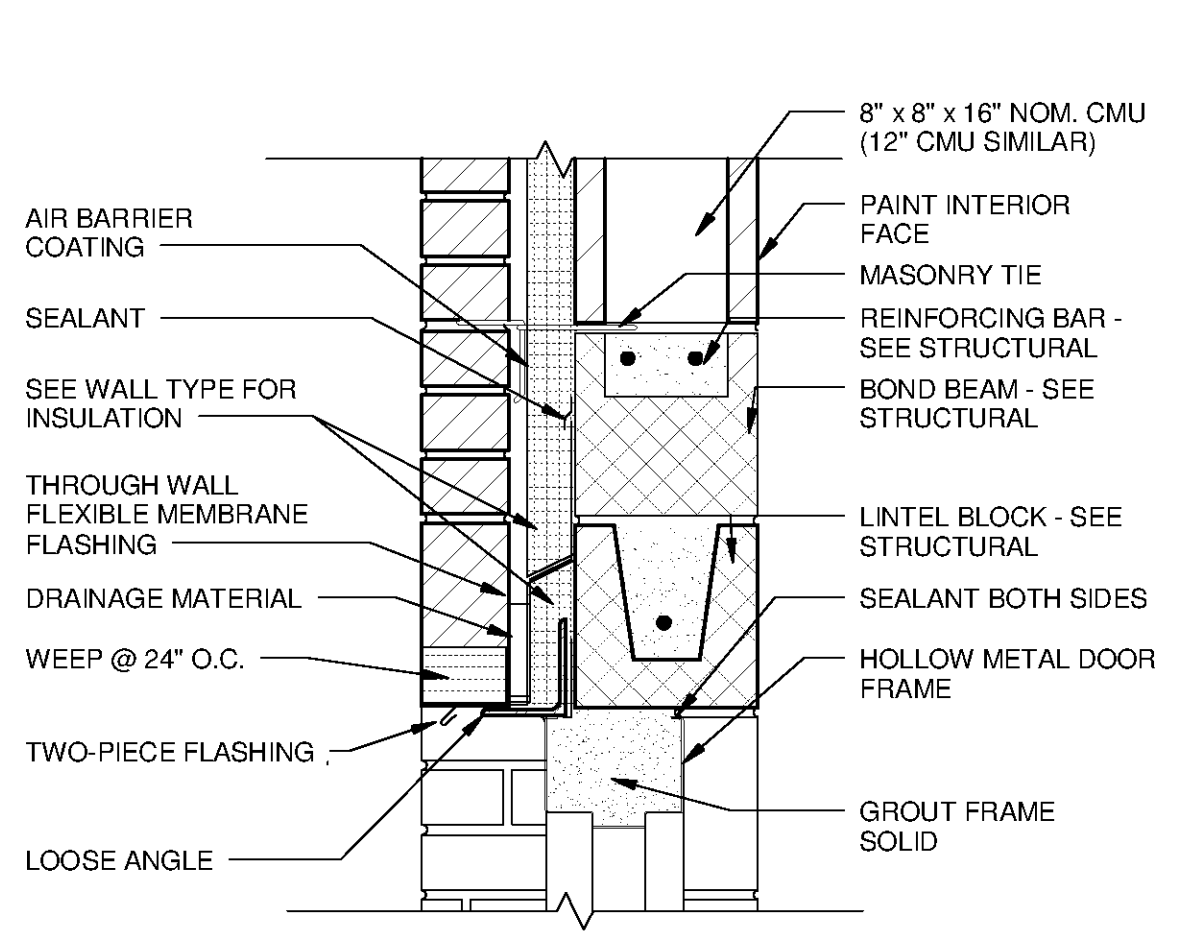

**4 DOOR HEAD TYPE A.1**  
SCALE: 1 1/2" = 1'-0"

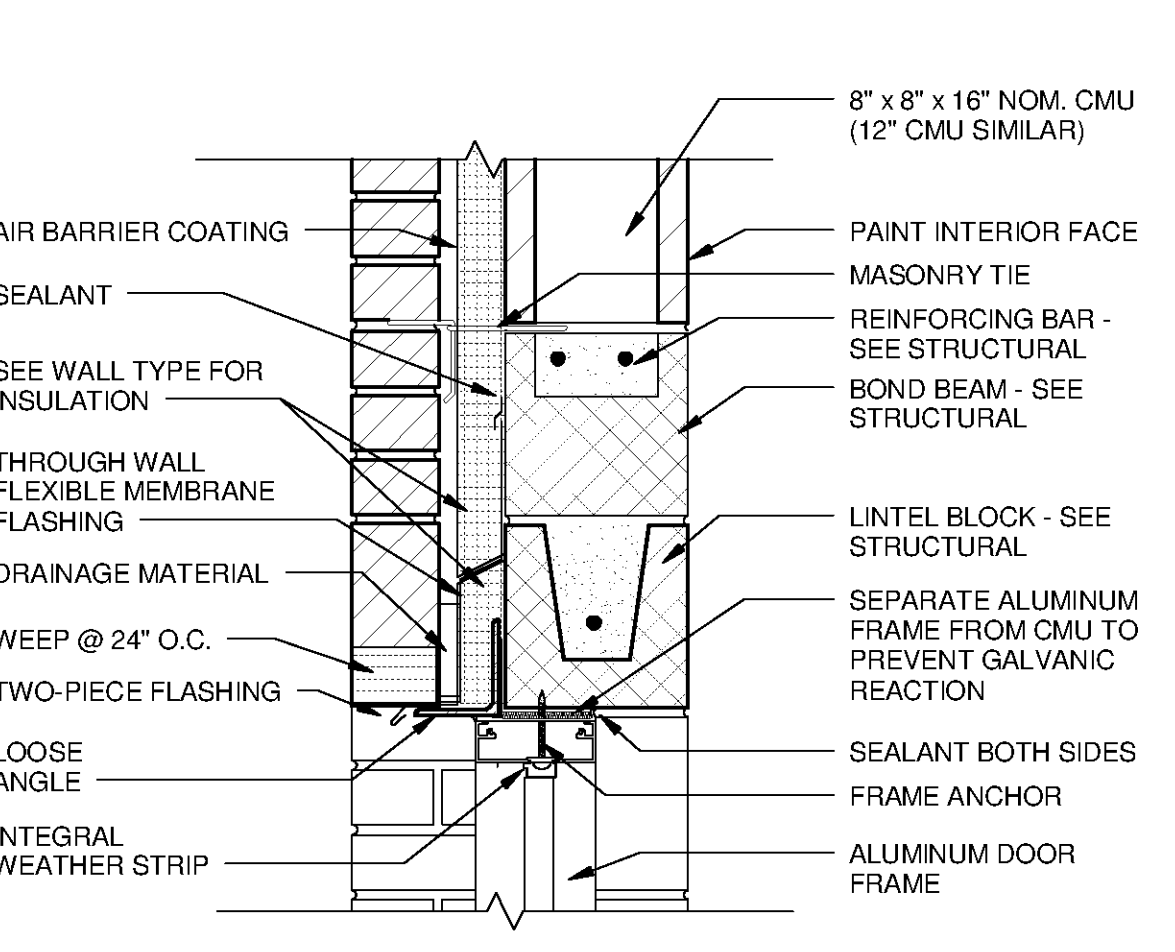

**1 DOOR HEAD TYPE A**  
SCALE: 1 1/2" = 1'-0"

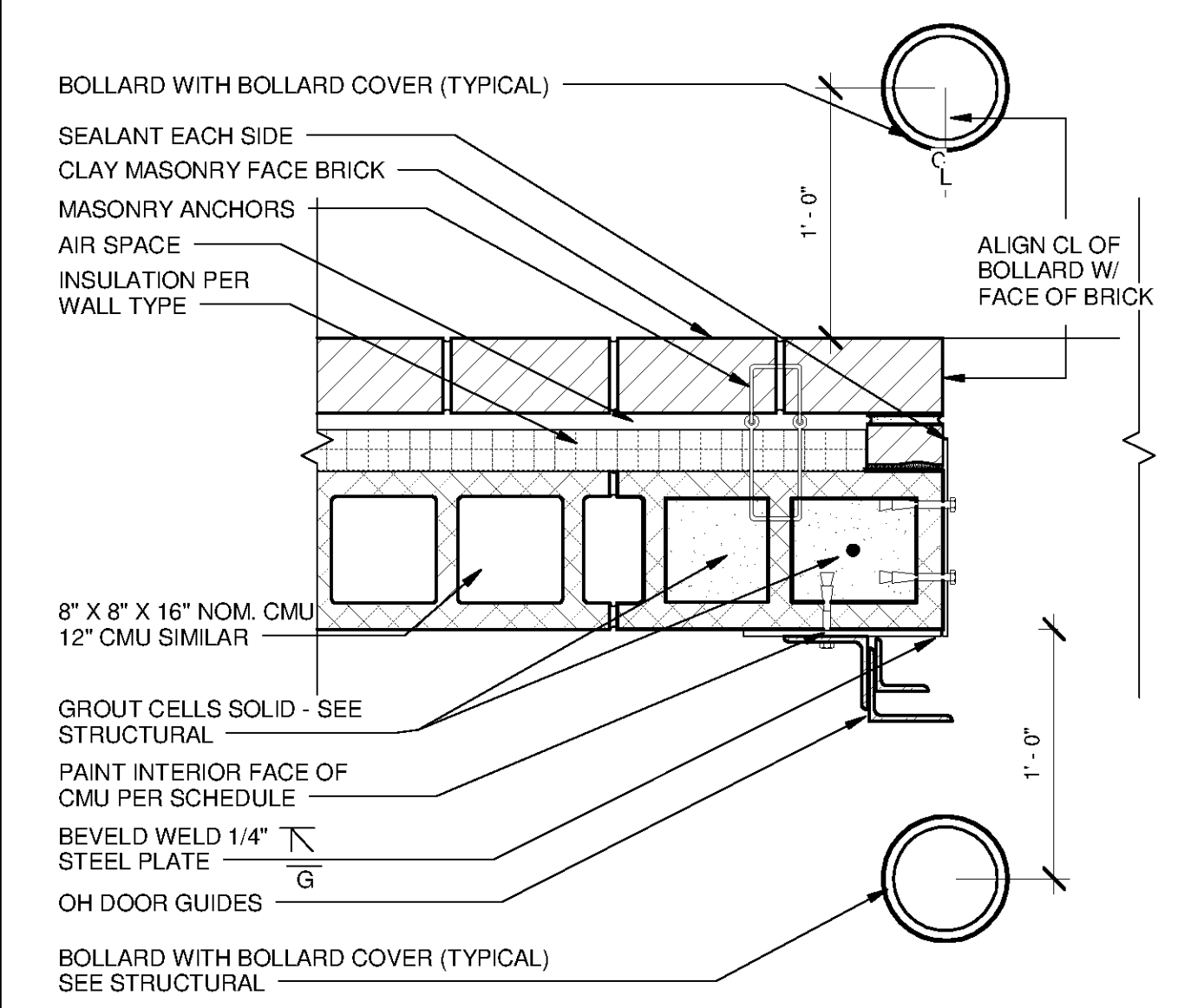

**13 DOOR JAMB TYPE OH.1**  
A-3102 SCALE: 1 1/2" = 1'-0"

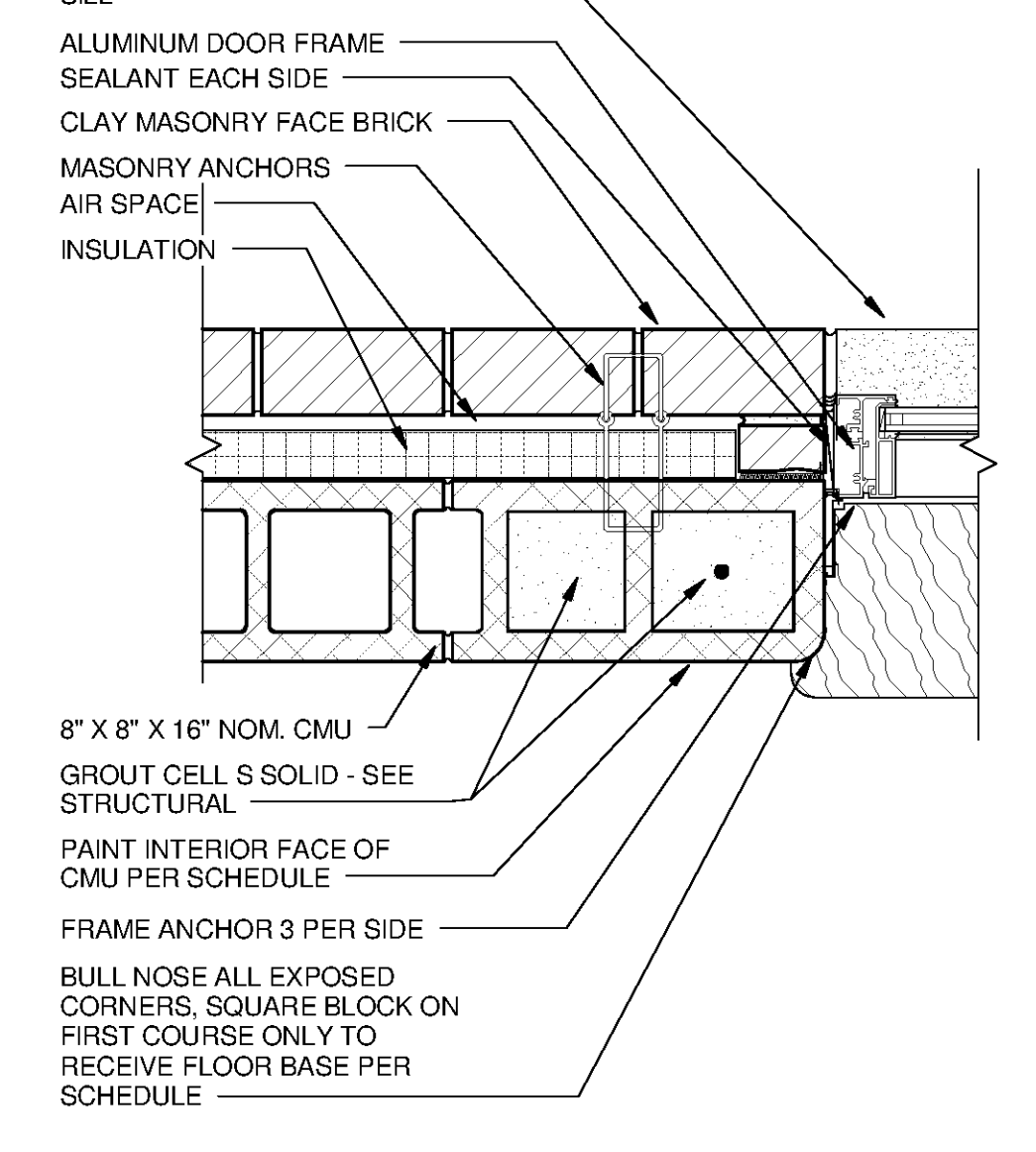

**10 WINDOW JAMB TYPE WJ-A**  
A-3102 SCALE: 1 1/2" = 1'-0"

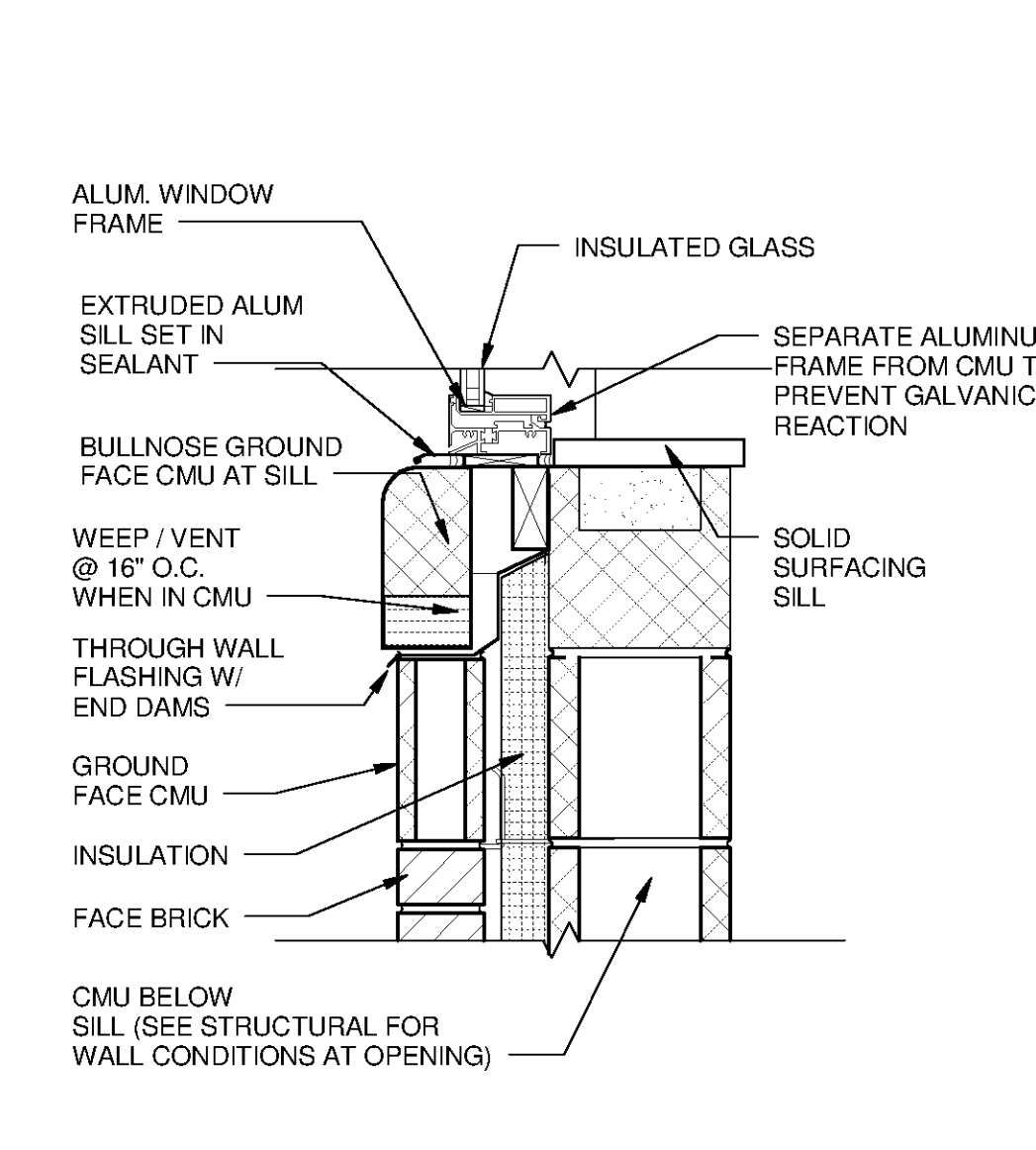

**8 WINDOW SILL TYPE WS-A**  
SCALE: 1 1/2" = 1'-0"

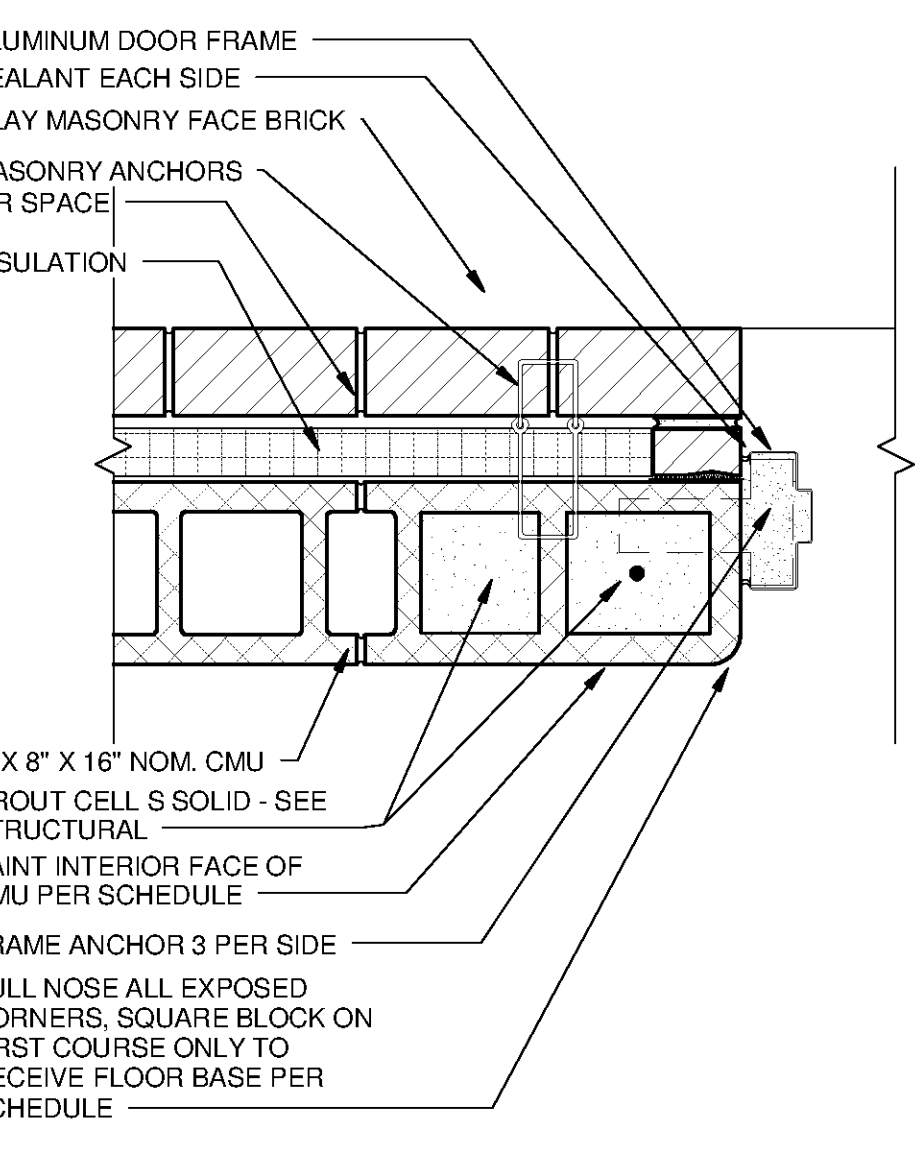

**5 DOOR JAMB TYPE A.1**  
A-3102 SCALE: 1 1/2" = 1'-0"

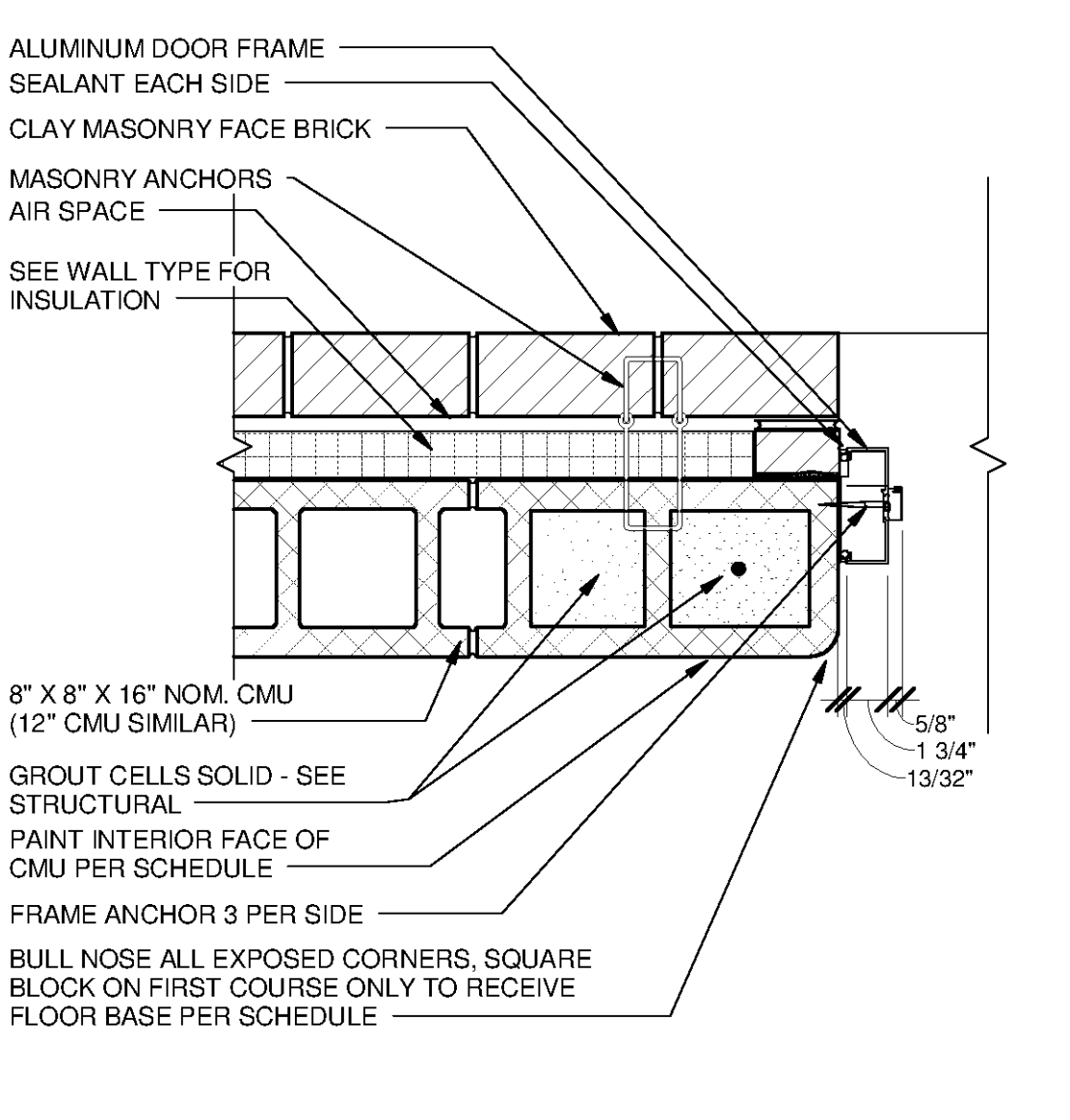

**2 DOOR JAMB TYPE A**  
SCALE: 1 1/2" = 1'-0"

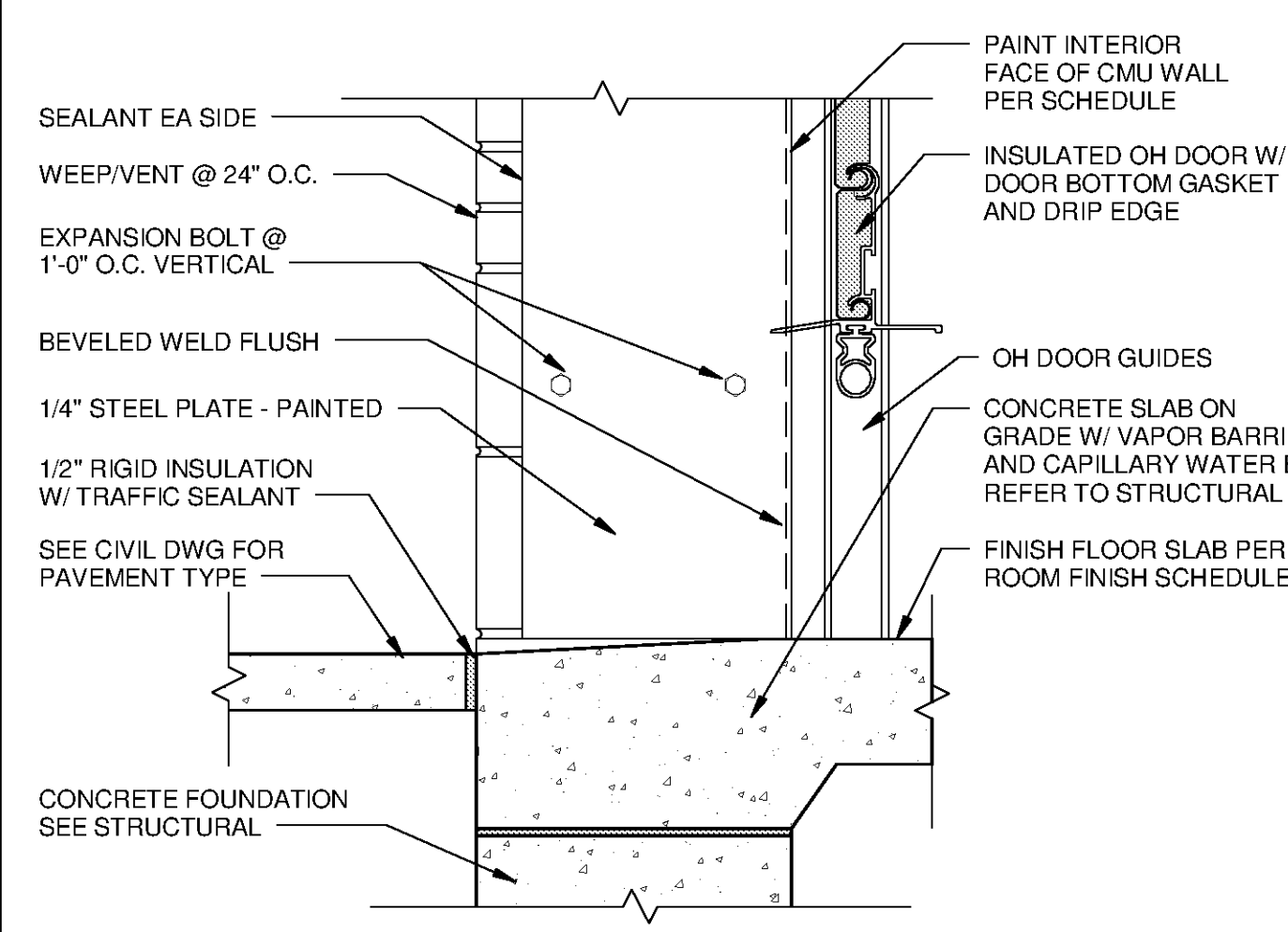

**14 DOOR SILL TYPE OH.1**  
SCALE: 1 1/2" = 1'-0"

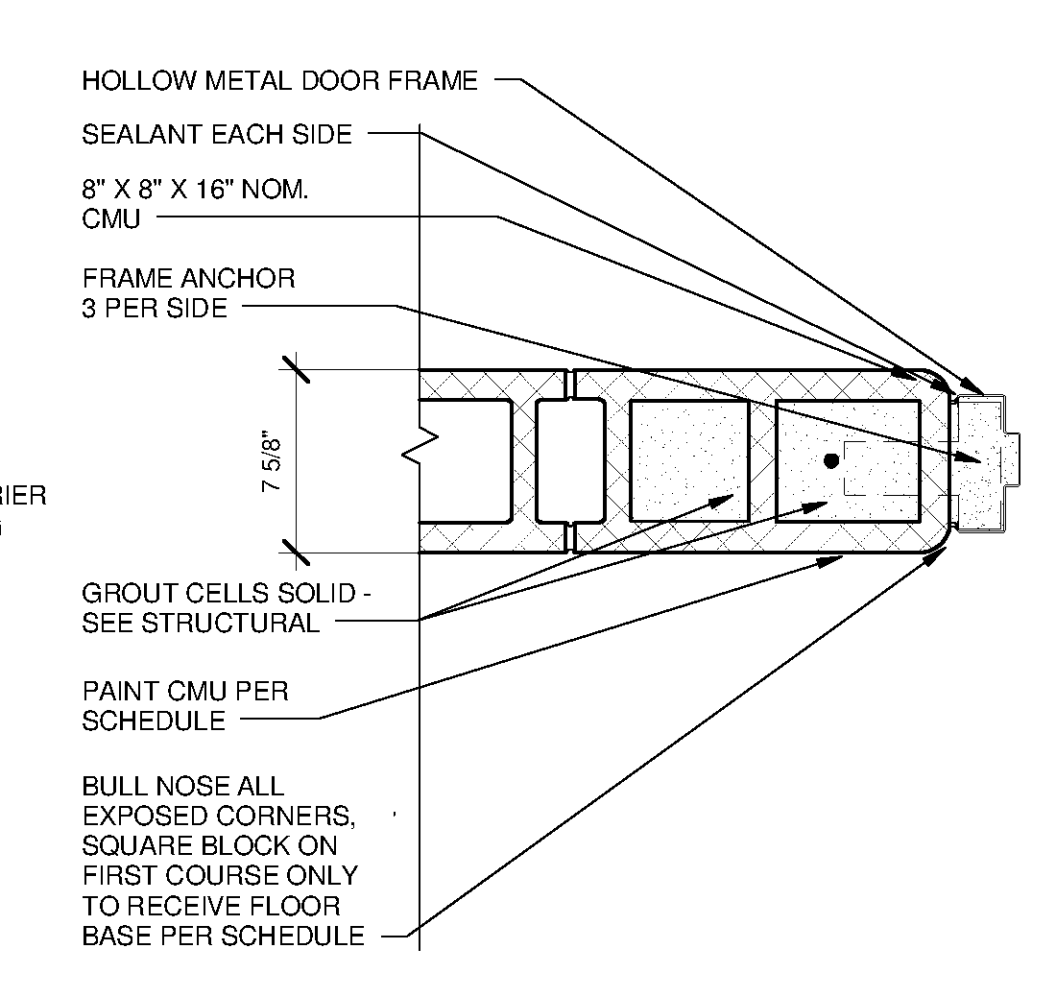

**11 DOOR JAMB TYPE B.1**  
SCALE: 1 1/2" = 1'-0"

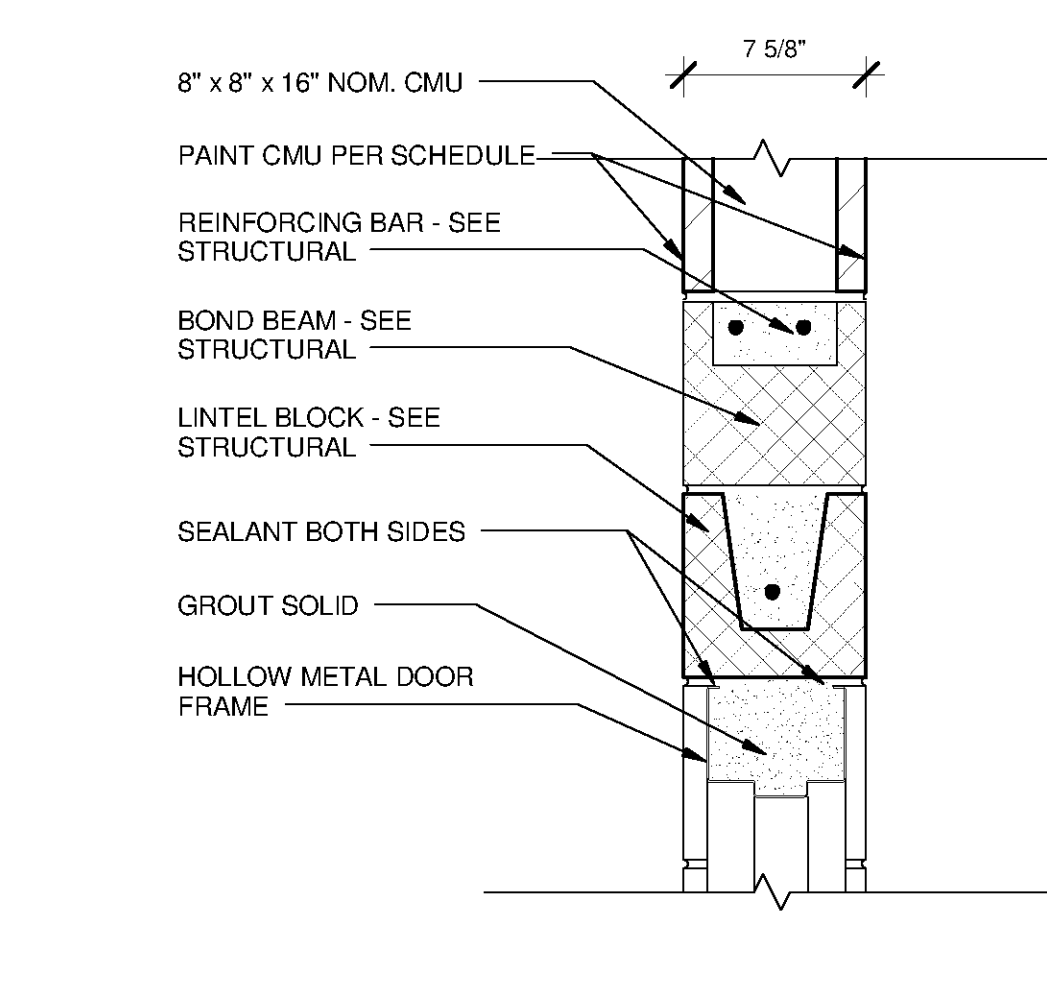

**9 DOOR HEAD TYPE B.1**  
SCALE: 1 1/2" = 1'-0"

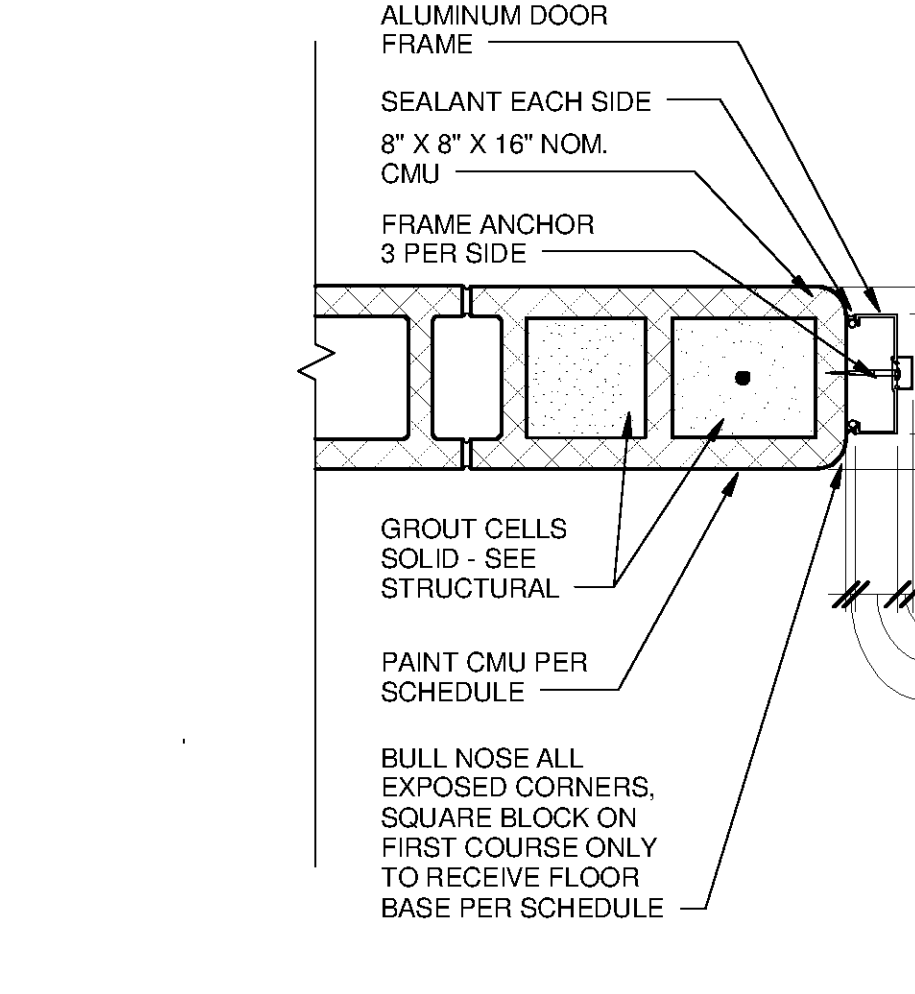

**6 DOOR JAMB TYPE B**  
SCALE: 1 1/2" = 1'-0"

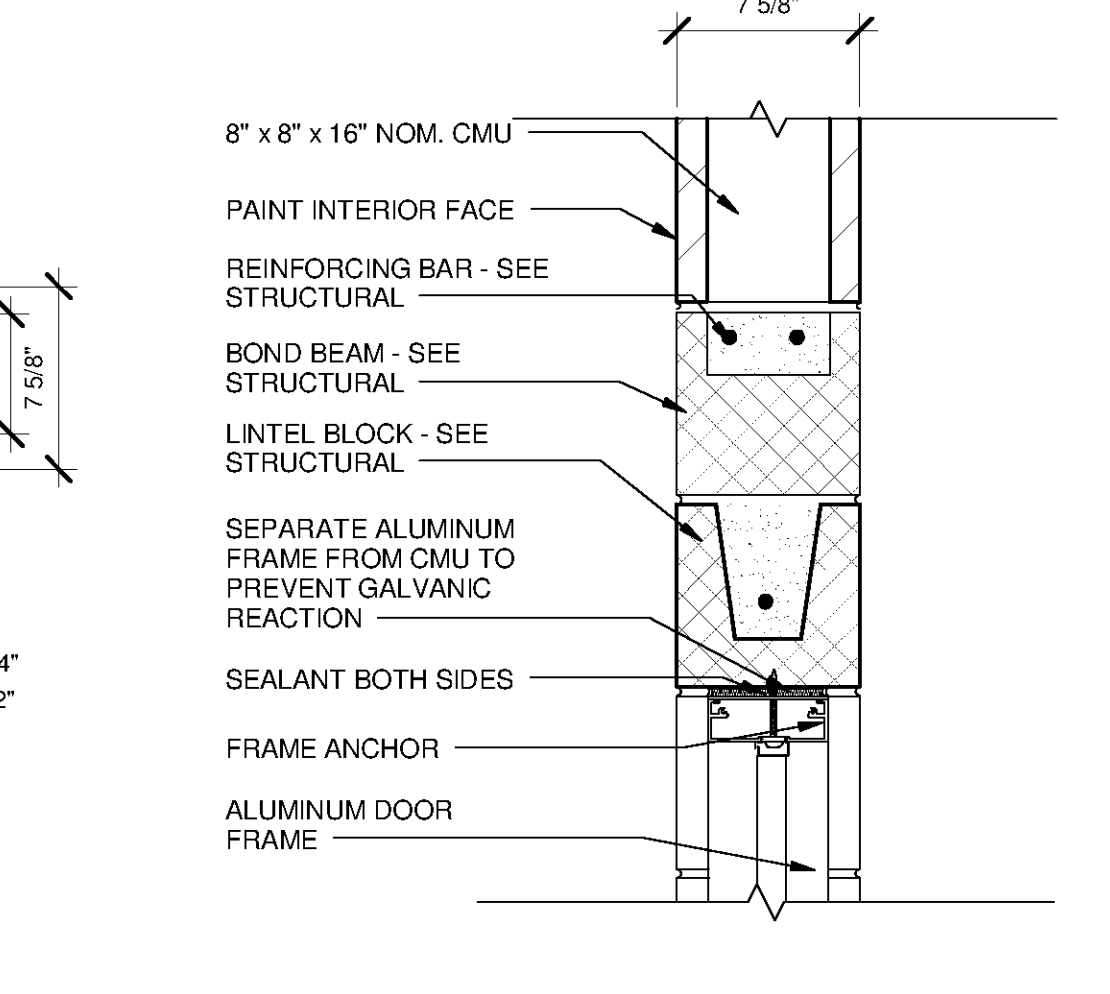

**3 DOOR HEAD TYPE B**  
SCALE: 1 1/2" = 1'-0"

**TETRA TECH**  
www.tetrattech.com  
101 QUALITY CIRCLE, SUITE 140  
HUNTSVILLE, ALABAMA 35806  
PHONE: (256) 424-4077 FAX: (256) 424-4087

**BID SET**  
SEALING  
6512  
10/21/14

MARK	DATE	DESCRIPTION

HUNTSVILLE UTILITIES  
SOUTHEAST WATER TREATMENT PLANT

**STANDARD ARCHITECTURAL DETAILS**

Project No.: 200-11740-10003  
Designed By: Q.BIAGI  
Drawn By: Q.BIAGI  
Checked By: D.GALANTE