

1 CONTROL JOINT SEALANT
SCALE: 1 1/2" = 1'-0"

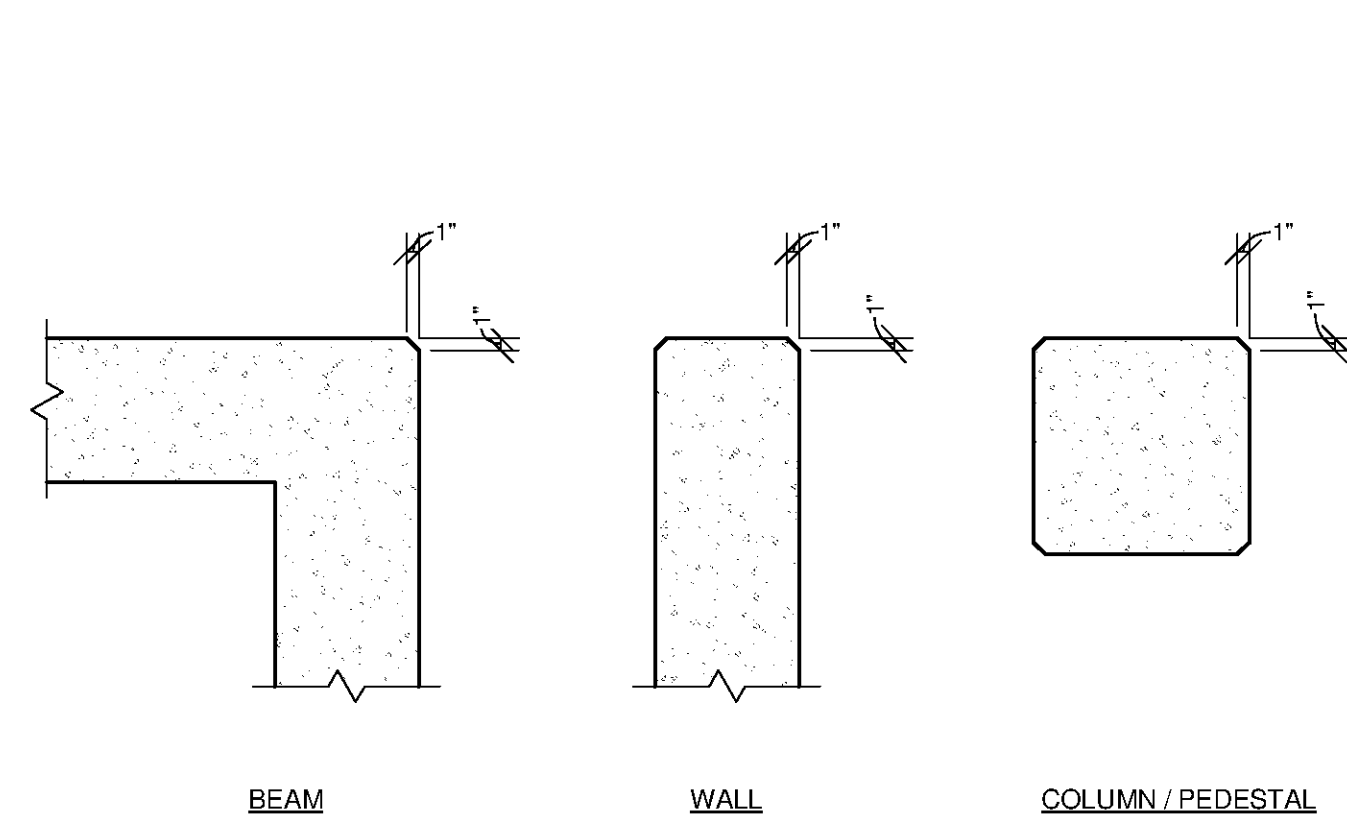

2 CHAMFER DETAILS
SCALE: 3/4" = 1'-0"

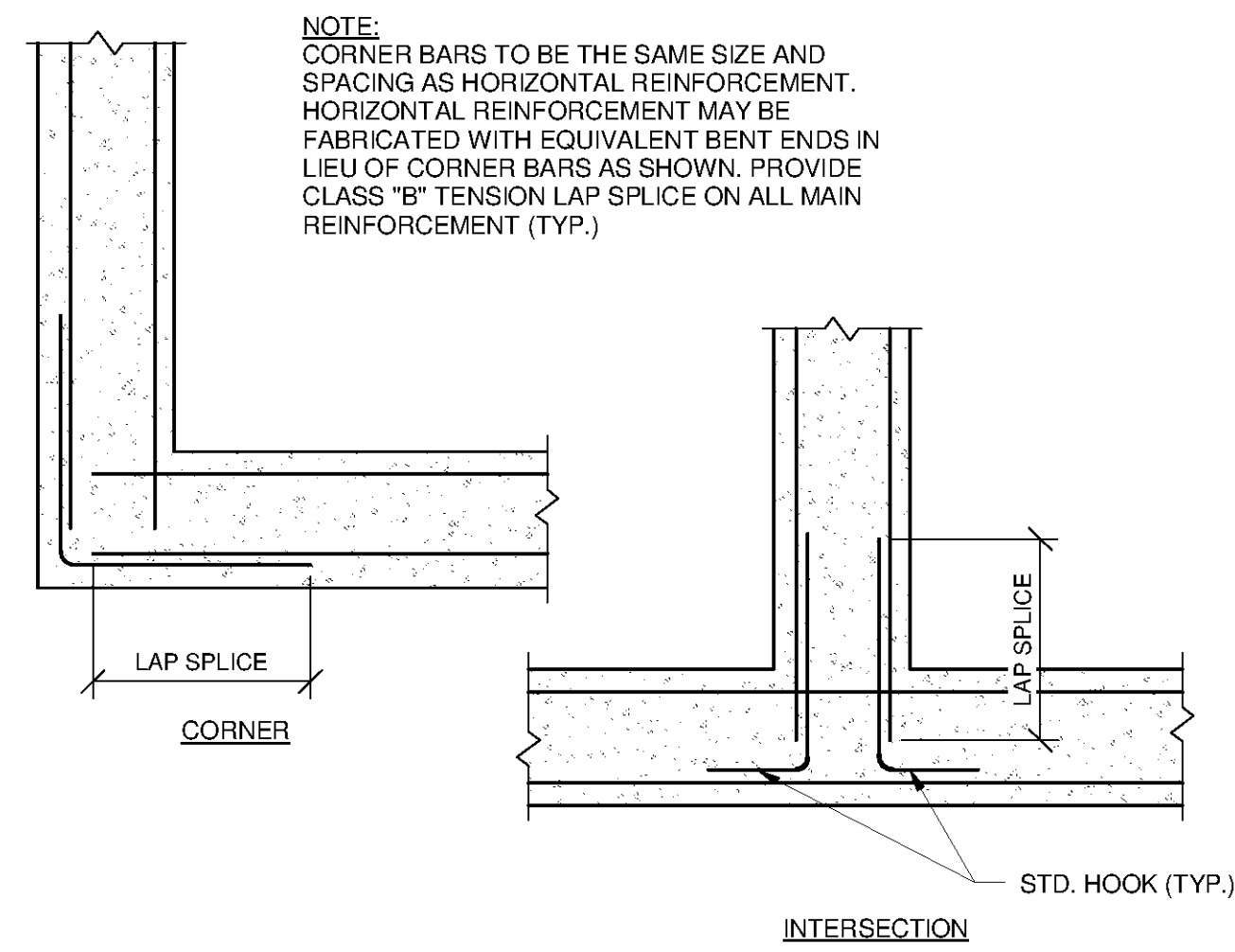

3 WALL CORNERS @ BLDG WALLS
SCALE: 3/4" = 1'-0"

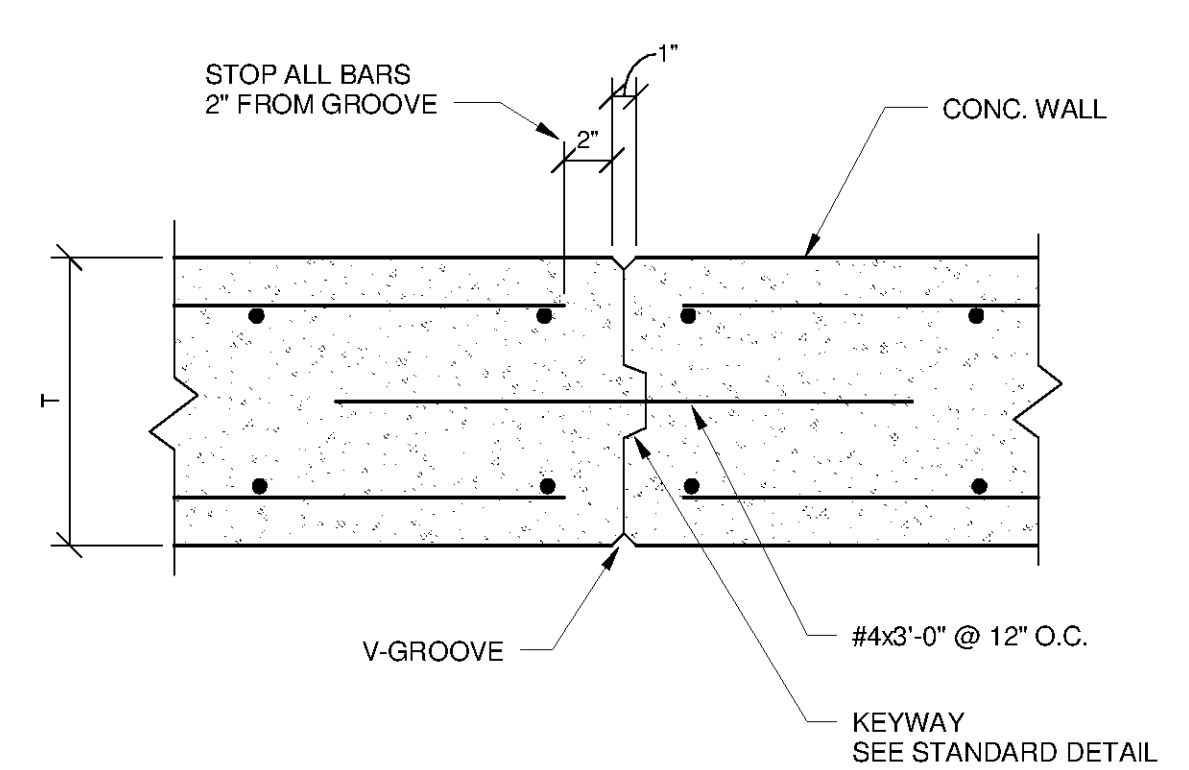

4 CONSTRUCTION JOINT @ BLDG. WALLS
SCALE: 1 1/2" = 1'-0"

NOTE:

1. MAX. CONST. JT. SPACING = 60'-0" O.C.
2. A CONSTRUCTION JT. SHALL BE LOCATED WITHIN 15'-0" OF A WALL CORNER.
3. ADJACENT WALL POURS SHALL BE DELAYED 2 DAYS MIN. TO ALLOW CURING OF PREVIOUS POUR.

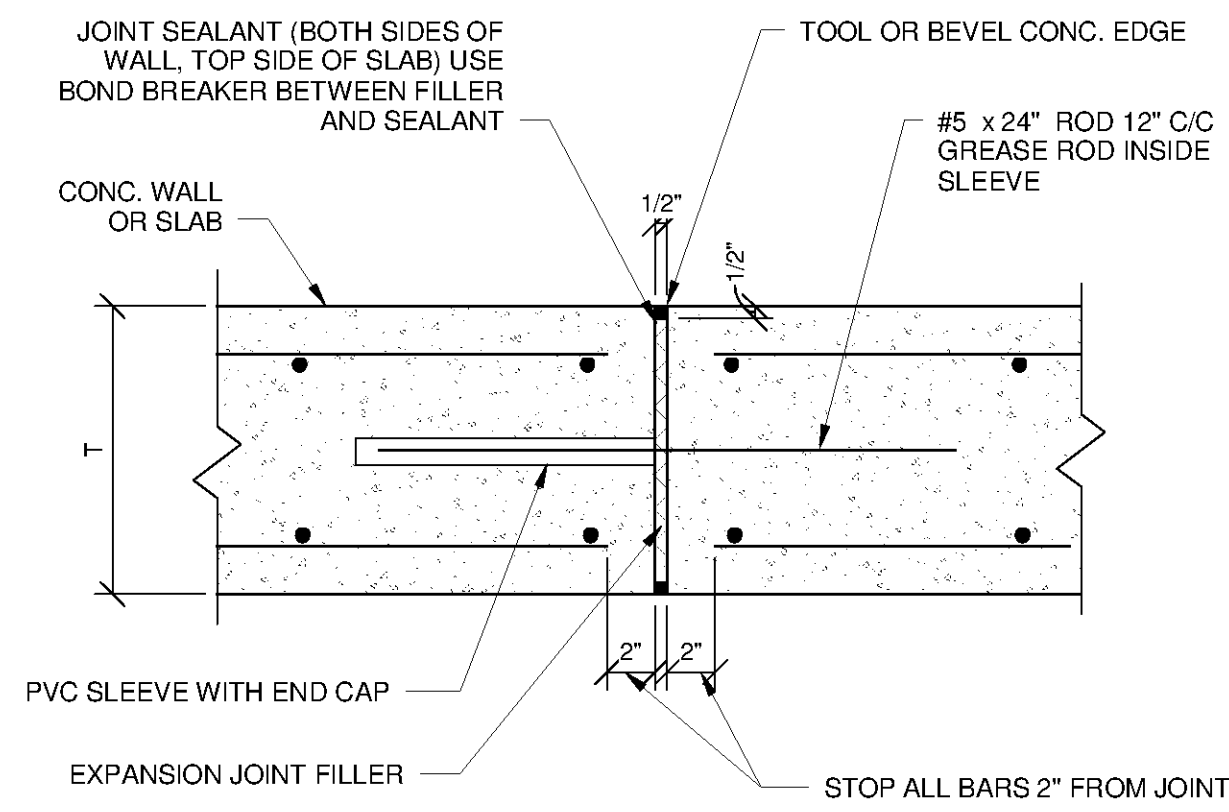

5 EXPANSION JOINT @ BLDG. WALLS
SCALE: 1 1/2" = 1'-0"

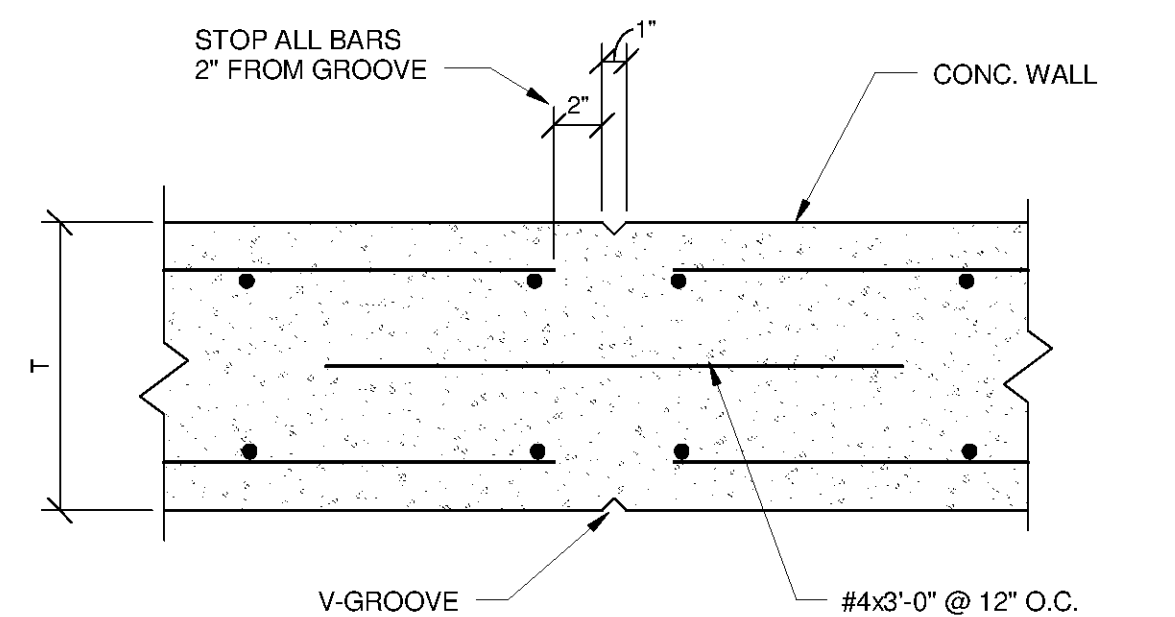

6 CONTROL JOINT @ BLDG WALL
SCALE: 1 1/2" = 1'-0"

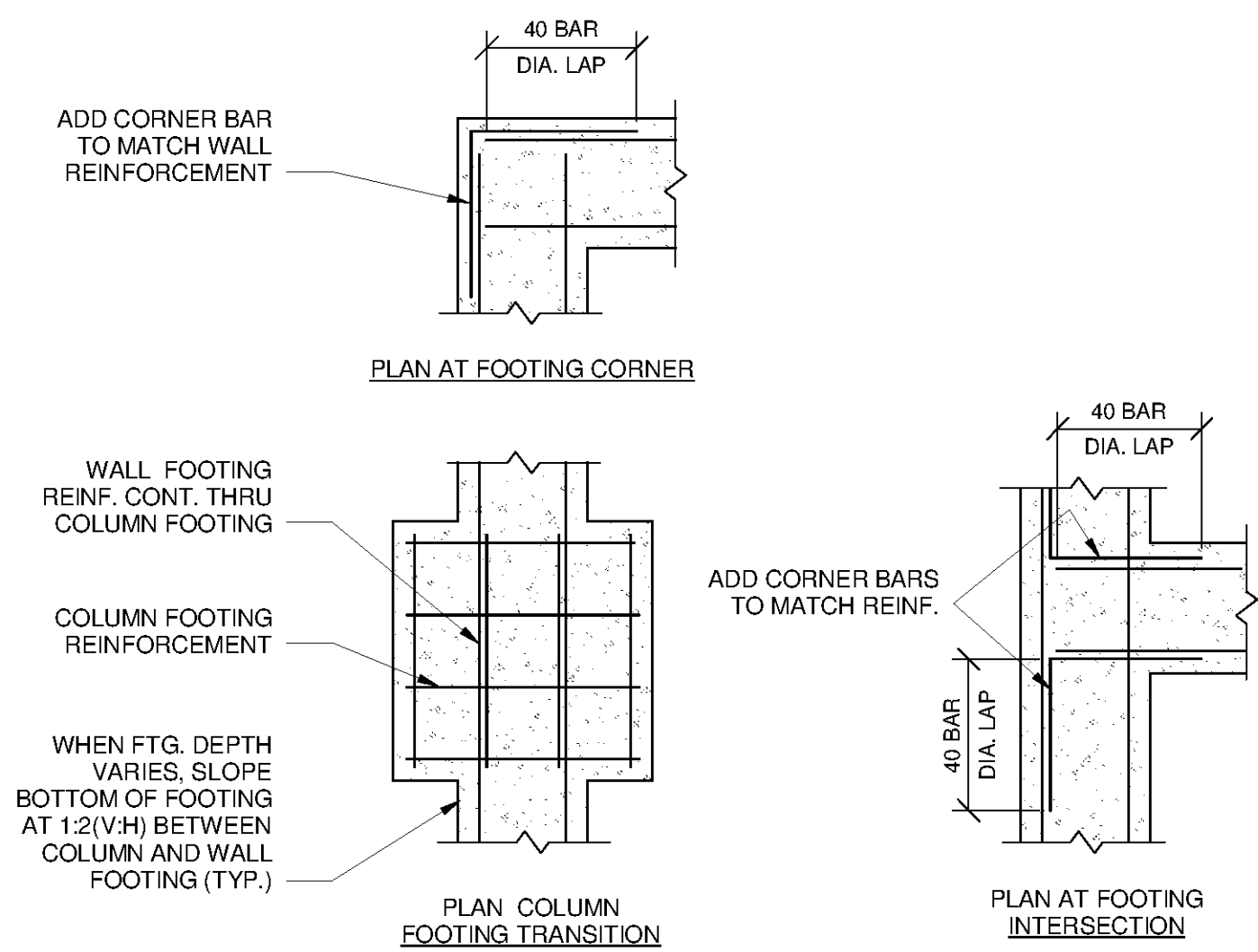

7 TYP. FOOTING INTERSECTIONS
SCALE: 3/4" = 1'-0"

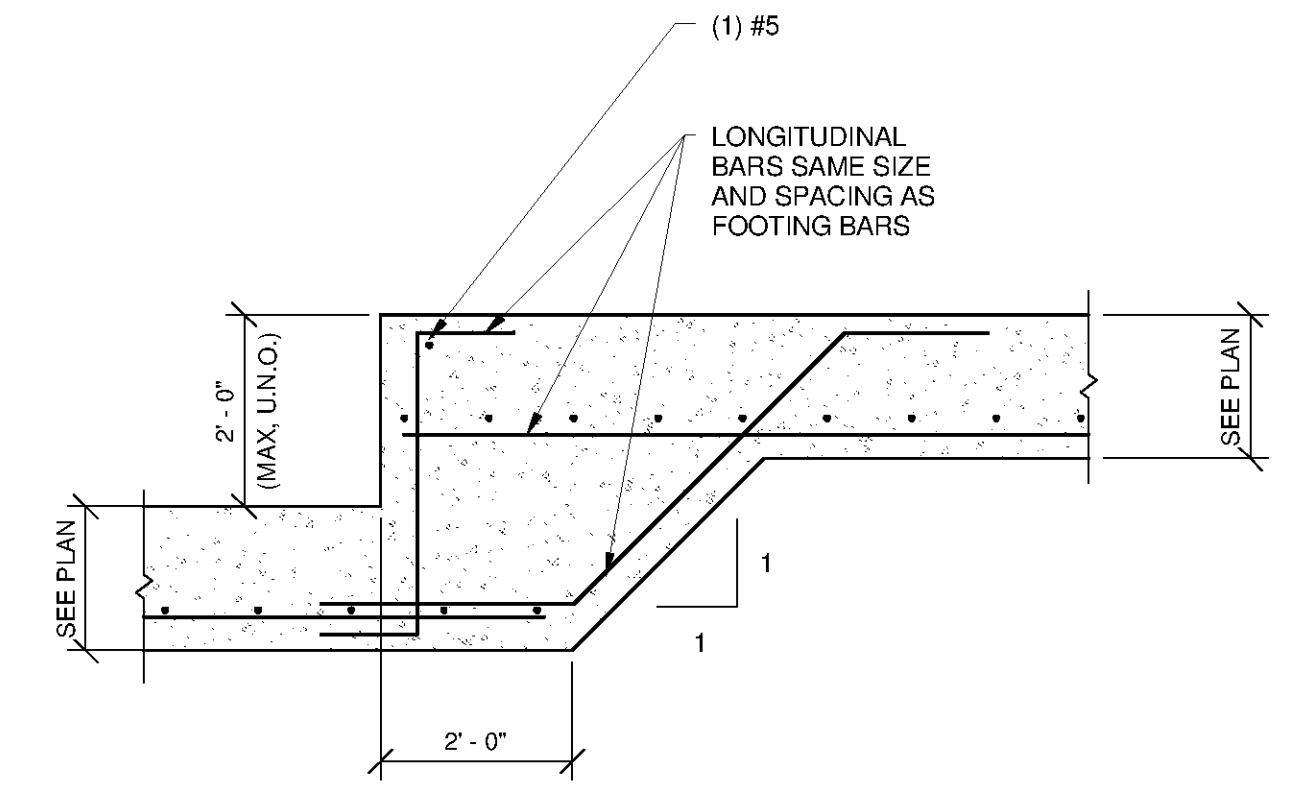

8 STEPPED FOOTING DETAIL
SCALE: 1/2" = 1'-0"

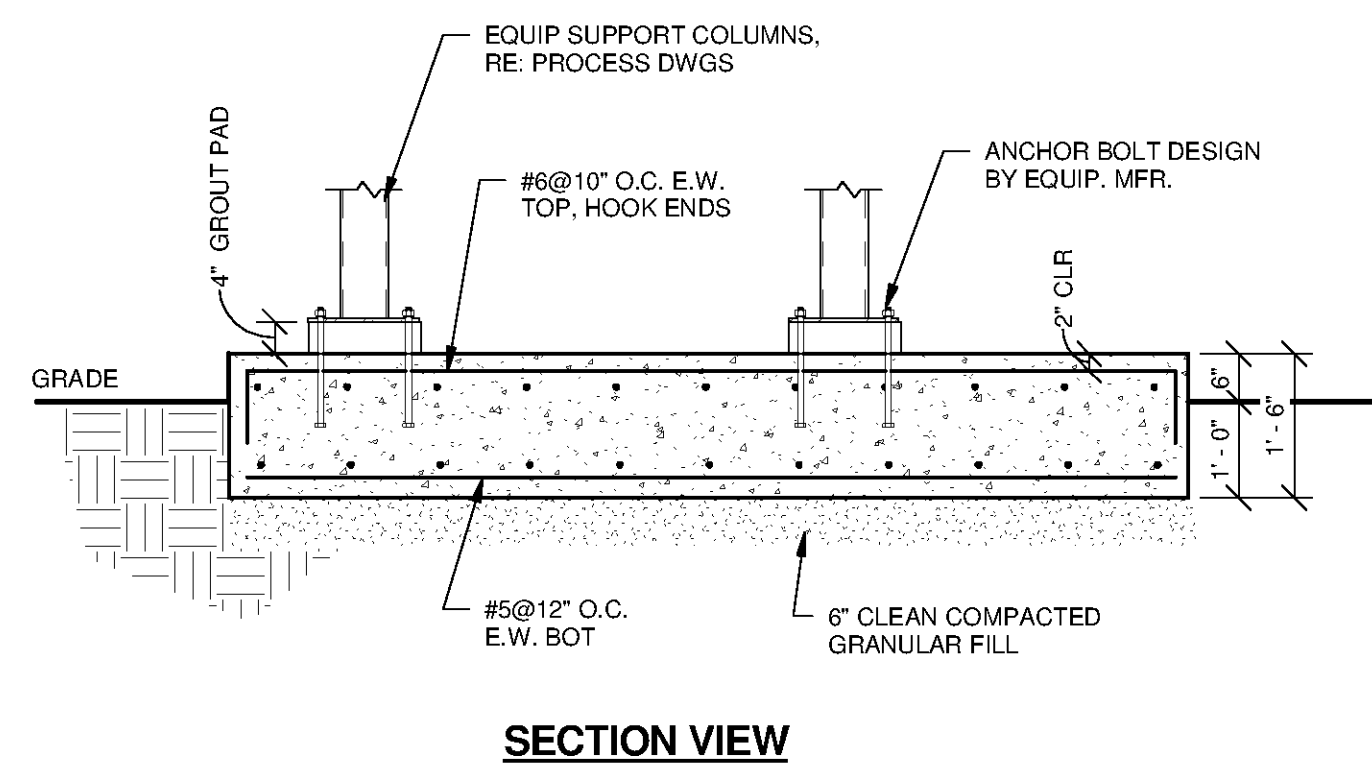
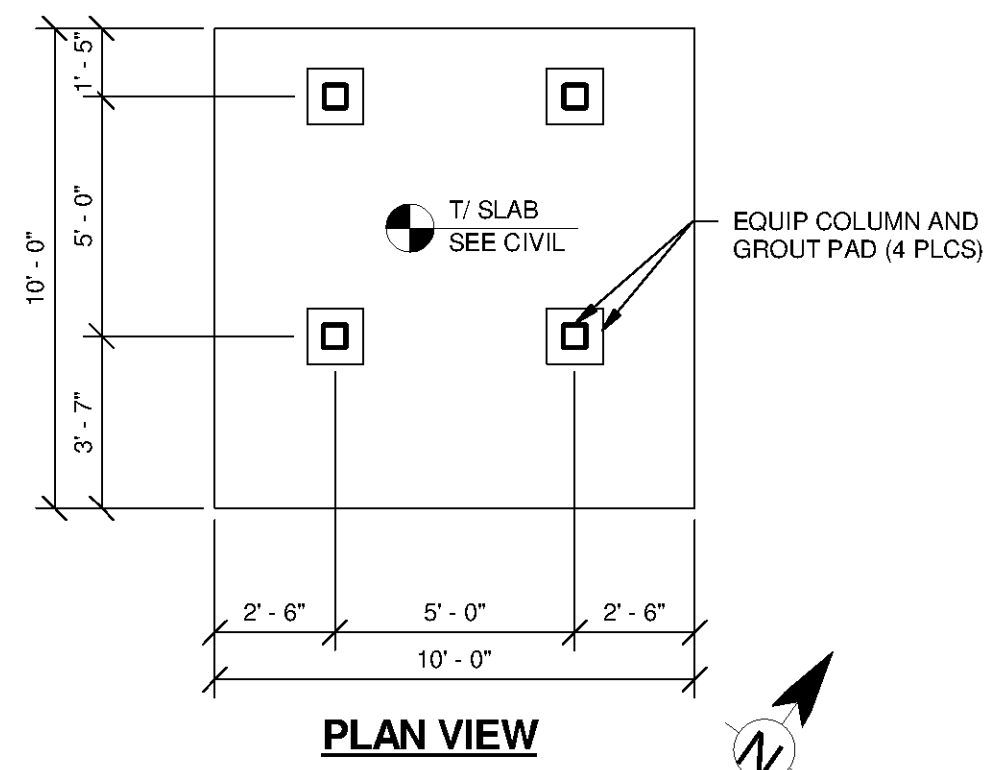

9 PAC EQUIPMENT PAD (1 REQ'D)
SCALE: 1/4" = 1'-0"

| BY | DATE | DESCRIPTION |
|----|------|-------------|
| | | |
| | | |
| | | |
| | | |