

---

**SECTION 01040**

**Project Coordination**

**PART 1 – GENERAL**

**1.01 SCOPE**

- A. Management of the Project shall be with a logical method of construction planning, inspection, scheduling and cost value documentation.
- B. The work under this Section includes all surface and subsurface condition inspections and coordination by the Contractor necessary for the proper and complete performance of the Work.
- C. This Section applies to the work of every division and every section of these Specifications.
- D. The Contractor shall become thoroughly familiar with the requirements of the Contract Documents, as well as jobsite conditions and the work of separate contractors (if any), and shall make any adjustments necessary to maintain the Project schedule.
- E. Close coordination will be required by the Contractor with the City, Engineer, other authorities having jurisdiction, separate contractors (if any), and others having an interest in the Project. Through close coordination, the Contractor will ensure that all work on the site, access to and from the site, and the general conduct of the operations is maintained in a safe and efficient manner, and that disruption and inconvenience to existing streets and property are minimized.

**1.02 SITE CONDITIONS**

- A. Inspection:
  - 1. Prior to performing any work under a section, the Contractor shall carefully inspect the installed work of other trades and verify that all such work is complete to the point where the work under that section may properly commence.
  - 2. The Contractor shall verify that all materials, equipment, and products to be installed under a section may be installed in strict accordance with the original design and pertinent reviewed shop drawings.

3. Observation of the Work by the Engineer or others shall not be interpreted as relieving the Contractor of its responsibility for the coordination of all Work, superintendence of the Work, or scheduling and direction of the Work.
- B. Discrepancies:
  1. In the event of discrepancy, immediately notify the Engineer.

### **1.03 EXISTING FACILITIES**

- A. The existing services shall remain in FULL operation while new construction is in progress.
- B. The Contractor shall coordinate the work with the City so that the construction will not restrain or hinder the operation of the existing wastewater facilities. If, at any time, any portion of the wastewater facilities is out of service, the Contractor must obtain prior approval from the City as to the date, time, and length of time that portion of the wastewater facilities is out of service.
- C. Connections to the existing facilities or alteration of existing facilities will be made at times when the piping or facility involved is not in use, or at times, established by the City, when the use of piping or facility can be conveniently interrupted for the period needed to make the connection or alteration.
- D. After having coordinated the work with the City, the Contractor shall notify the Engineer of the time, time limits, and methods of each connection or alteration and have the approval of the Engineer before any work is undertaken on the connections or alterations.
- E. Before any roadway or facilities are blocked off, the City's approval shall be obtained to coordinate operations for these facilities, and any signage, plating, bypass pumping, sinking of bypass conduits, ramping, or any other temporary accommodation work shall be implemented by the contractor as directed by the City.

### **1.04 COORDINATION**

- A. Carefully coordinate work with all other trades and subcontractors to insure proper and adequate interface of the work of other trades and subcontractors with the work of every section of these Specifications.
- B. The Contractor shall coordinate operations with all utility companies in or adjacent to the area of Contractor's work. The Contractor shall require said

utility companies to identify/ field verify location of each of their respective utility and provide drawings as necessary to locate them.

- C. The Contractor shall so schedule the Contractor's Work that the Contractor does not interrupt the operation of any existing facility, including water mains and sewers. In the event certain tie-ins or other operations make it necessary to interrupt the operation of existing facilities, the City will be notified and such work will be done at a time and in a manner acceptable to the City /Engineer.

END OF SECTION

[This page intentionally left blank]



---

**SECTION 01055**

**CONSTRUCTION STAKING**

**PART 1 GENERAL**

**1.01 SCOPE**

- A. Construction staking shall include all of the surveying work required to layout the Work and control the location of the finished Project. The Contractor shall have the full responsibility for constructing the Project to the correct horizontal and vertical alignment, as shown on the Drawings, as specified, or as ordered by the Engineer.
- B. The Contractor shall assume all costs associated with rectifying work constructed in the wrong location.

**1.02 QUALITY ASSURANCE**

- A. The Contractor shall hire, at the Contractor's own expense, a Surveyor with current registration in the State of Georgia, acceptable to the Owner, to provide project construction staking and confirmation of the vertical and horizontal alignment.
- B. Any deviations from the Drawings shall be confirmed by the Engineer prior to construction of that portion of the Project.

**1.03 SUBMITTALS**

- A. Submit name and address of Registered Surveyor to Engineer.
- B. On request of Engineer, submit documentation to verify accuracy of construction staking.
- C. Submit record drawings in accordance with PART 3 of the Section.

**PART 2 PRODUCTS**

**(NOT USED)**

**PART 3 EXECUTION**

**3.01 PROJECT CONDITIONS**

- A. The Drawings provide the location of principal components of the Project. The

Engineer may order changes to the location of some of the components of the Project or provide clarification to questions regarding the correct alignment.

- B. The Engineer will provide the following:
1. One vertical control point on the Project site with its elevation shown on the Drawings.
  2. A minimum of two horizontal control points on the Project site with their coordinates shown on the Drawings.

### **3.02 GENERAL**

- A. From the information shown on the Drawings and the information to be provided as indicated in paragraph 3.01 above, the Contractor shall:
1. Be responsible for establishing GPS control coordinate control system, setting reference points and/or offsets, establishment of baselines, and all other layout, staking, and all other surveying required for the construction of the Project.
    - a. The horizontal position of all points shall be referenced to the North American datum of 1983 (1986 adjustment) in the Georgia State Plane West 1002 Coordinate System.
    - b. The vertical position of all points shall be referenced to the North American Vertical datum of 1988.
    - c. All coordinate values shall be delivered as grid coordinates in US Survey Feet.
    - d. The minimum data accuracy required for all record drawings shall be +/- 0.10 USFT (one tenth of one foot).
  2. Safeguard all reference points, stakes, grade marks, horizontal and vertical control points, and shall bear the cost of re-establishing same if disturbed.
  3. Stake out the limits of construction to ensure that the Work does not deviate from the indicated limits.
  4. Stake out the pipeline horizontal and vertical alignment.
  5. Be responsible for all damage done to reference points, baselines, center lines and temporary bench marks, and shall be responsible for the cost of re-establishment of reference points, baselines, center lines and temporary bench marks as a result of the operations.

6. Maintain a complete, accurate log of all control and survey work as it progresses.

- B. Baselines shall be defined as the line to which the location of the Work is referenced, i.e., edge of pavement, road centerline, property line, right-of-way or survey line.

### **3.03 STAKING PRECISION**

- A. The precision of construction staking shall match the precision of components location. Staking of utilities shall be done in accordance with standard accepted practice for the type of utility.
- B. The precision of construction staking required shall be such that the location of the sanitary and/or storm sewers can be established for construction and verified by the Engineer. Where the location of components/appurtenances of the sanitary or storm sewer ( i.e. manholes, drain inlets, etc.) are not dimensioned, the establishment of the location of these components shall be based upon scaling these locations if drawings are not provided with relation to readily identifiable land marks, i.e. survey reference points, power poles, manholes etc.
- C. Paved Surfaces: The Contractor shall establish a reference point for establishing and verifying the paving subgrade and finished grade elevations. Any variance with grades shall be identified by the Contractor and confirmed by the Engineer prior to constructing the base.
- D. The Contractor's attention is directed to Section 01040, Paragraph 3.06.

### **3.04 RECORD DRAWINGS**

- A. Sanitary and Storm Sewers
  - 1. The Contractor shall submit record drawings which show the final installed location of the sewer and storm drain and survey data for all installed sanitary and storm sewer pipe and service connections. Survey data shall consist of final coordinates for all manholes, catch basins, tunnel and casing limits, CIP/pipe bursting delineations, service connections and invert elevations for all manholes, catch basins and other structures.
- B. The record drawings shall also indicate the horizontal and vertical location,

dimensions and materials of all utilities encountered during excavation.

- C. 2 full size hard copies of record drawings shall be furnished to the Engineer for review. Each record drawing shall be stamped with the name of the Contractor, signed and dated by the Contractor's Project Manager and signed, sealed and dated by the Surveyor. Also provide 2 compact disks containing signed and sealed PDFs of the final record drawings.
- D. The Contractor's attention is directed to GC-28.4 and GC-38.5 relative to maintenance and submittal of Record Drawings.

**+ + + END OF SECTION 01055 + + +**

**REGULATORY REQUIREMENTS**

**PART 1 GENERAL**

**1.01 SCOPE**

- A. Permits and Responsibilities: The Contractor shall be responsible for complying with all applicable federal, state, county and municipal laws, codes and regulations, in connection with the prosecution of the Work and for obtaining any and all permits including but not limited to NPDES permits for storm water discharges from the Work site.
- B. Permits and applications for this project are identified in Part 3 of this Section.
- C. The Contractor shall take proper safety and health precautions to protect the Work, the workers, the public and the property of others. Contractor shall comply with all requirements of the permitting authority, whether permits were obtained by the Contractor or not.

**PART 2 PRODUCTS**

**(NOT USED)**

**PART 3 EXECUTION**

**3.01 NPDES PERMITS FOR STORM WATER DISCHARGES**

- A. The Contractor shall comply with the provisions of the Authorization to Discharge under the National Pollutant Discharge Elimination System, Storm Water Discharges Associated with Construction Activity for Infrastructure Construction Projects, Georgia Environmental Protection Division General Permit No. GAR 100002, including but not limited to filing permit applications, filing Notice of Intent (NOI), filing Notice of Termination (NOT), performing inspections and monitoring and performing record keeping as required.

**3.02 GDOT ENCROACHMENT PERMITS**

- A. Portions of this project may be constructed within right of ways under the jurisdiction of Georgia Department of Transportation (GDOT).
- B. The Contractor will submit permit applications to GDOT for Right of Way Encroachment for installation of pipelines and appurtenances and connections to existing pipelines for the above areas.

**3.03 CITY LANE CLOSURE PERMITS**

- A. The City/Engineer, in conjunction with the Contractor, will submit permit applications to the City’s Department of Public Works, Office of Transportation for all lane/road closures required for completion of the project. Refer to Section 01550, Traffic Regulation.

**3.04 OTHER PERMITS**

- A. The Contractor shall submit applications for and obtain all other permits required in conjunction with completion of the Work of the Contact.

**3.05 GENERAL**

- A. The Contractor shall pay for all remaining permits, fees and licenses required for construction of the project. Payment for all permits, fees and licenses required for construction shall be reimbursed to the Contractor under Allowance Item entitled Special Permit Requirements.
- B. The Contractor shall examine all permits and agreements and conform to the requirements contained therein, including the purchase of additional bonds or insurance as specified therein, and such requirements are hereby made a part of these Contract Documents as though the same were set forth herein. Failure to examine the permit and agreement applications will not relieve the Contractor from compliance with the requirements stated therein.

**+ + + END OF SECTION 01060 + + +**

**SECTION 01091**

**CODES AND STANDARDS**

**PART 1 GENERAL**

**1.01 DESCRIPTION**

- A. Whenever reference is made to conforming to the standards of any technical society, organization, body, code or standard, it shall be construed to mean the latest standard, code, specification or tentative specification adopted and published at the time of advertisement for Bids. This shall include the furnishing of materials, testing of materials, fabrication and installation practices. In those cases where the Contractor's quality standards establish more stringent quality requirements, the more stringent requirement shall prevail. Such standards are made a part hereof to the extent which is indicated or intended.
- B. The inclusion of an organization under one category does not preclude that organization's standards from applying to another category.
- C. In addition, all work shall comply with the applicable requirements of local codes, utilities and other authorities having jurisdiction.
- D. All material and equipment, for which a UL Standard, an AGA or NSF approval or an ASME requirement is established, shall be so approved and labeled or stamped. The label or stamp shall be conspicuous and not covered, painted, or otherwise obscured from visual inspection.
- E. The standards which apply to this Project are not necessarily restricted to those organizations which are listed in Article 1.02.

**1.02 STANDARD ORGANIZATIONS**

- A. Piping and Valves:

ACPA	American Concrete Pipe Association
ANSI	American National Standards Institute
API	American Petroleum Institute
ASME	American Society of Mechanical Engineers
AWWA	American Water Works Association
CISPI	Cast Iron Soil Pipe Institute
DIPRA	Ductile Iron Pipe Research Association
FCI	Fluid Controls Institute
MSS	Manufacturers Standardization Society

NCPI National Clay Pipe Institute  
NSF National Sanitation Foundation  
PPI Plastic Pipe Institute  
Uni-Bell PVC Pipe Association

B. Materials:

AASHTO American Association of State Highway and Transportation  
Officials  
ANSI American National Standards Institute  
ASTM American Society for Testing and Materials

C. Painting and Surface Preparation:

NACE National Association of Corrosion Engineers  
SSPC Steel Structures Painting Council

D. Aluminum:

AA Aluminum Association  
AAMA American Architectural Manufacturers Association

E. Steel and Concrete:

ACI American Concrete Institute  
AISC American Institute of Steel Construction, Inc.  
AISI American Iron and Steel Institute  
CRSI Concrete Reinforcing Steel Institute  
NRMA National Ready-Mix Association  
PCA Portland Cement Association  
PCI Pre-stressed Concrete Institute

F. Welding:

ASME American Society of Mechanical Engineers  
AWS American Welding Society

G. Government and Technical Organizations:

APHA American Public Health Association  
APWA American Public Works Association  
ASA American Standards Association  
ASAE American Society of Agricultural Engineers  
ASCE American Society of Civil Engineers  
ASQC American Society of Quality Control  
ASSE American Society of Sanitary Engineers



CFR	Code of Federal Regulations
CSI	Construction Specifications Institute
EPA	Environmental Protection Agency
FS	Federal Specifications
IAI	International Association of Identification
ISEA	Industrial Safety Equipment Association
ISO	International Organization for Standardization
ITE	Institute of Traffic Engineers
MUTCD	Manual of Uniform Traffic Control Devices
NBFU	National Board of Fire Underwriters
NFPA	National Fluid Power Association
NBS	National Bureau of Standards
NISO	National Information Standards Organization
OSHA	Occupational Safety and Health Administration
SPI	Society of the Plastics Industry, Inc.
USDC	United States Department of Commerce
WEF	Water Environment Federation

H. Roadways:

AREMA	American Railway Engineering and Maintenance-of-Way Association
GDOT	Georgia Department of Transportation

I. Plumbing:

AGA	American Gas Association
PDI	Plumbing Drainage Institute
SPC	SBCC Standard Plumbing Code

J. Equipment:

AFBMA	Anti-Friction Bearing Manufacturers Association, Inc.
AGMA	American Gear Manufacturers Association
CEMA	Conveyor Equipment Manufacturers Association
DEMA	Diesel Engine Manufacturers Association
OPEI	Outdoor Power Equipment Institute, Inc.
PTI	Power Tool Institute, Inc.
RIA	Robotic Industries Association
SAMA	Scientific Apparatus Makers Association

**1.03 SYMBOLS**

Symbols and material legends shall be as scheduled on the Drawings.

**PART 2 PRODUCTS**

**(NOT USED)**

**PART 3 EXECUTION**

**(NOT USED)**

**+ + + END OF SECTION 01091 + + +**

---

**SECTION 01200****Measurement and Payment****PART 1 – GENERAL****1.01 SCOPE**

- A. Work includes furnishing all plant, labor, equipment, tools, materials, and performing all operations required to complete the Work satisfactorily, in-place, as specified and as indicated on the Drawings.
- B. All costs of required items of work and incidentals necessary for the satisfactory completion of the Work shall be considered as included in the Total Bid. The cost of work not directly covered by the pay items shall be considered incidental to the contract and no additional compensation shall be allowed.
- C. The Contractor shall take no advantage of any apparent error or omission on the Drawings or Specifications, and the Engineer shall be permitted to make corrections and interpretations as may be deemed necessary for fulfillment of the intent of the Contract Documents.

**1.02 UNIT PRICE ITEMS**

- A. Payment for all work shall be in accordance with the unit price bid items in the Bid Schedule and shall be full compensation for all labor, materials, and equipment required to furnish, install, construct, and test the Work covered under the unit price bid item. Work for which there is no price schedule item will be considered incidental to the Work and no additional compensation shall be allowed.
- B. Payment will be made only for the actual quantities of work performed in compliance with the Drawings and Specifications. The Contractor will be paid an amount equal to the approved quantity times applicable unit price. Any unused balance of the unit price work shall revert to the City upon completion of the project.
- C. All unit price work shall be considered as part of the Work to be performed within the time limits specified elsewhere for Substantial Completion and Project Completion. No increase in contract time will be allowed for increases in quantities of unit price work performed beyond the quantities shown in the Bid Schedule, unless it can be demonstrated that the additional Work performed under the unit price item is on the critical path of the Project Schedule.

**1.03 MEASUREMENT OF QUANTITIES**

A. The basis of payment will be the unit prices and/or lump sum amounts included in the Contractor’s bid. The distances stated for pipeline and manhole rehabilitation work are the City’s best estimate of work to be performed by this contract. Payment for pipeline rehabilitation, pipe replacement or any other items of work for which payment will be made on a linear foot or vertical foot basis will be based on the Contractor’s measurement, contingent on verification by City inspectors. Nothing in this Section shall be construed as providing for additional payment beyond the bid items. Prices will include, but not limited to all labor, equipment and materials necessary for a complete installation in accordance with the Contract Documents. All incidental work necessary for a complete and operable project shall be included in the price bid. No payment will be made for partially completed bid items.

B. Measurement Devices

1. Scales shall be inspected, tested, and certified by the applicable Weights and Measures Departments within the past year and shall be of sufficient size and capacity to accommodate the conveying vehicle.
2. Metering devices shall be inspected, tested, and certified by the applicable department within the past year.
3. Volume shall be determined by cubic dimension by multiplying mean length by mean width by mean height or thickness.
4. Area shall be determined by square dimension by multiplying mean length by mean width or height.
5. Linear measurement shall be measured by linear dimension, along the item centerline or mean chord.
6. Stipulated price measurement shall include items measured by number, weight, volume, area, length, or combination thereof as appropriate

<b>Item</b>	<b>Description</b>	<b>Method of Measurement</b>
AC	Acre	Field Measure
AL	Allowance	
CY	Cubic Yard	Field Measure within limits specified or shown, or measured in vehicle by volume, as specified
DAY	Calendar Day	
EA	Each	Field Count
GAL	Gallon	Field Measure
HR	Hour	
LB	Pound(s)	Weight Measure by Scale
LF	Linear Foot	Field Measure
LS	Lump Sum	Unit is one; no measurement will be

<b>Item</b>	<b>Description</b>	<b>Method of Measurement</b>
SF	Square Foot	made
SY	Square Yard	
TON	Ton	Weight Measure by Scale (2,000 lb)
VF	Vertical Foot	Field Measure

**PART 2 – BID ITEMS**

**2.01 GENERAL CONDITIONS**

- A. Mobilization/Demobilization (Not to Exceed 3% of Bid Total) – Bid Item 1-A-1000: Contractor will be paid a lump sum amount for all costs associated with the mobilizations and demobilizations of equipment, and project management as directed by the Engineer for the project. The first payment will be remitted for mobilization up to a maximum of 50% the amount bid upon Engineer’s verification that the Contractor has fully provided all necessary personnel, such as labor, equipment, materials, field offices, parking areas, staging areas, safety signage, public outreach, project signs (four each) per Special Conditions Section SC-14 and Section 01351, magnetic vehicle signs and yard signs per Section 01580, administrative items, etc. necessary to commence the Work. The remaining 50% will be remitted at the mid-point of the project.

Project Management shall include incidental cost associated but not limited to the General Conditions, and Special Conditions, Project Controls, Submittals, Quality Assurance-Quality Control, Temporary Facilities & Construction Operations, Project Identification and Signs, Transportation and Handling, Storage and Protection, Record Documents, Retrieval Systems for Manholes, Site Preparation, Permits, Safety & Security, police officers, and overhead. The remainder of the amount bid will be remitted based on a percentage of liner installed on a monthly basis and upon satisfactory demobilization and restoration of the various project areas upon completion of the Work, provision of all project record documentation and any other close-out type of documentation required.

The Contractor will be paid for providing, implementing and utilizing the project control tools as specified in Special Conditions Section SC-16 and Section 01350. The payment shall include qualified personnel to operate the specified tools, software licenses, training sessions, training manuals, and consulting services for setup and implementation as required and specified.

The maximum amount for this item shall not exceed 3% of the total bid. The payment shall be on a LUMP SUM (LS) basis, which includes furnishing all

materials, labor, and incidentals necessary to complete the work prorated throughout the life of the project.

- B. Work Zone Staging and Traffic Control, Various Functional Classifications (Per Link) – Bid Items 1-D-1405: The Measurement for payment will be per link. Payment will constitute full compensation for all costs for furnishing, installing, maintaining and removing work zone staging and temporary traffic control per each link of roadway based upon the current functional classification of the affected roadway as defined by the Federal Highway Administration. The term affected roadway shall be defined as the limits of physical construction activity and shall not include peripheral signage or other traffic control related activities which may be required. A link is defined as a section roadway between two nodes or intersections. In the event a single work zone spans one or more intersections, the average link length will be used to determine the eligible quantity of work zones for payment. The unit price bid shall include, but not be limited to furnishing, installation, maintenance and removing all traffic control devices, temporary signage, temporary pavement markings and shall include flagging, permits and other means necessary for safe guidance and protection of vehicular and pedestrian traffic through the Work Zone to complete the entire scope of work which is located within or requires traffic control of the designated roadway link based upon the functional classification and site conditions. No additional payment will be remitted for multiple work zone staging or traffic control setups. An initial payment not to exceed 50% of the unit price bid will be remitted for satisfactory establishment, staging and traffic implementation upon completion of pre-construction survey services and provision of corresponding CCTV files. The remaining payment will be remitted upon completion of all work on the affected link including provision of post construction CCTV files. Separate payment will not be made for the provision of uniformed traffic control officers required as part of a permit. If police officers are not required by a permit, but are requested by the City, separate payment will be made. All traffic control measures and plans shall conform to the requirements of the Manual on Uniform Traffic Control Devices (MUTCD), Part 6 (Temporary Traffic Control), latest edition, as published by the US DOT / FHWA. The above referenced bid items are applicable to work within roadways with the following functional classifications:

- 17- Collector Street
- 16- Minor Arterial Street
- 14- Urban Principal Arterial
- 12- Urban Freeway and Expressway
- 11- Interstate Principal Arterial

Functional Classification Maps for the Atlanta Metro Counties are available through Georgia's Department of Transportation (GDOT)

website at [http://www.dot.state.ga.us/DOT/plan-prog/transportation\\_data/function\\_class\\_maps/index.shtml](http://www.dot.state.ga.us/DOT/plan-prog/transportation_data/function_class_maps/index.shtml). In the event that a functional classification assignment conflict exists between the drawings and the GDOT, the GDOT classification shall preside. The contractor shall submit proposed traffic control plans to the Engineer at least 48 hours before the work begins for authorization. Payment may be withheld at the discretion of the Engineer if plans are not submitted for authorization in a timely manner. Traffic control for roadways with “local” or “rural” functional classifications are considered incidental to the work and the cost shall be included in the unit price for the work performed (including provision of uniformed traffic control officers if required). No separate payment will be made for traffic control roadways with functional classification other than those stated herein, unless otherwise authorized by the Engineer for exceptional circumstances.

## 2.02 SITEWORK - GENERAL

- A. Clearing, Disposal & Grading for Access Route - Bid Item 2-H-2910: Measurement for payment will be per linear foot (LF). Payment will constitute full compensation for all costs associated with clearing, disposal, rough grading and geotextile underlayment for grading and preparation work necessary to install a 10 foot wide, 6 inch deep construction access route in accordance with Section 02112 – Route Clearing, when authorized by the Engineer. The payment shall be made per linear feet of access route measured along the centerline of site access route from the point of commencement of construction to the furthest point of required access. Payment shall include, but not be limited to furnishing arborist tree survey, site plan, arborist tree removal permit, construction layout, clearing, grubbing, debris removal, grading, geotextile underlayment, labor, equipment and materials for the establishment of erosion control (except those erosion control items paid for elsewhere). Clearing shall also include removal of all interfering or objectionable material in the site access way, temporary drainage, and grading as necessary to facilitate equipment access to the work site. Payment will not be remitted for light clearing, disposal and grading of vegetative areas comprised of trees, brush or shrubs less than 6 inch caliper as this is considered light brush typically displaced with construction equipment.
- B. Unsuitable Soil Haul Off & Replace - Bid Item 2-H-3020: All soil determined to be unsuitable for backfill shall be removed and replaced. Soil shall be determined to be unsuitable by the Engineer in accordance with Specification Section 02200 – Earthwork in non paved areas. All costs for removal, hauling and disposal of the unsuitable material, as well as the cost for hauling and placing imported fill material shall be included in the unit price. Payment will be made on the basis of cubic yards (CY) removed with

replacement amount not to exceed the minimum backfill limits indicated on GC-2/ Detail 14, trench type I for flexible or rigid pipe installation. Payment will not be remitted for removal and replacement of unsuitable soil beyond the aforementioned trench limits regardless of the actual excavation/ trench dimension unless prior written authorization is provided by the Engineer.

- C. Additional Pipe Bedding Material - Bid Item 2-H-3025: Measurement for payment will be per cubic yard (CY) installed. Payment will constitute full compensation for all costs associated with additional pipe bedding material. Additional pipe bedding material is classified as bedding material needed to stabilize the base of a trench in addition to the pipe bedding specified in the Section 02200 and Drawing Details, provided that the trench excavation is properly de-watered per Specification Section 02140. The cost to install additional bedding, including all labor, equipment and materials, shall be included in the unit cost bid.
- D. Surface Stone, In-Place for Access Route - Bid Item 2-H-3900: Measurement for payment will be per ton of surge stone (4-inch to 6-inch size rip-rap) acceptably placed in accordance with Section 02112 – Route Clearing. Payment will constitute full compensation for all costs for all blading, finish grading, surge stone, and compaction work required to provide a stone surfaced route competent to support the weight of all vehicles and equipment required to perform the sewer rehabilitation work.. Stone tonnage shall be measured by load delivery tickets containing a printout of the net stone weight from a certified scale. Each delivery ticket shall be initialed and dated by the City Inspector on the date of placement. A copy of all applicable delivery tickets shall accompany each request for payment of this item. Payment under this item shall include full compensation for this work.
- E. Surface Stone and Filter Fabric, Removal from Access Route – Bid Item 2-H-3910: Measurement for payment will be per linear foot (LF). Payment will constitute full compensation for all costs associated with removal of the surge stone and filter fabric installed to access sewer rehabilitation site(s). The unit price shall include all costs associated with the removal and storage of stone and filter fabric, as well as backfill, compaction, grading and grassing to restore the site. The Contractor shall include all costs for transportation of stone and/or filter fabric, and/or disposal of debris resulting from the removal and site restoration. Surge stone and filter fabric shall only be removed by the Contractor when the road encroaches on private property outside of the sewer easement, or when directed by the Engineer.
- F. Tree Protection Fence - Bid Item 2-M-3010: Measurement for payment will be per linear foot (LF) for tree protection fence suitably installed and maintained per Section 02112. Payment will constitute full compensation for all costs associated with tree protection fencing, including installation, maintenance, repair, and removal.



- G. Rip Rap - Bid Item 2-N-1410: Measurement for payment will be per square yard (SY) for rip-rap suitably installed and maintained. Payment will constitute full compensation for all costs associated with installation of all riprap, including filter fabric underlayment, shown on the Drawings, specified in Section 02273 at a minimum 18 inch depth, or directed by the Engineer. When crossing a stream or ditch, the quantity eligible for payment shall be limited to 10 feet upstream and 10 feet downstream of top of trench excavation and from five feet from top of bank, across a creek or ditch, banks and bottoms, to five feet beyond top of bank. Any other areas at creeks or ditches disturbed by the Contractor, which require Rip Rap, shall be rip rapped at no additional cost to the City.
- H. Erosion Control Items: No payment will be made for any portion of the Project for which temporary erosion and sedimentation controls are not properly maintained. Quantities for payment shall be based upon actual quantity constructed and authorized by the Engineer. Erosion and sedimentation control measures shall comply with the requirements of Sections 02125 and 02270 of these Specifications; the Georgia Erosion and Sedimentation Act of 1975, as amended; the Manual for Erosion and Sediment Control of Georgia, latest edition; local soil erosion and sedimentation control ordinances; and the Contract Drawings.
1. Construction Exits (Co) - Bid Item 2-S-1010: Measurement for payment will be per each (EA) for construction exits suitably installed and maintained per the Manual for Erosion and Sediment Control of Georgia, latest edition. Payment will constitute full compensation for all costs associated with construction exits, including installation, maintenance, repair, and removal. Note: Construction exits are required to conform to the specific dimensions in the Manual for Erosion and Sediment Control of Georgia, latest edition. Construction exits installed to lesser dimension than those required shall be paid on a pro-rated basis accordingly.
  2. Sediment Barrier (Silt Fence – Type C) - Bid Item 2-S-1225: Measurement for payment will be per linear foot (LF) for Type C silt fence suitably installed and maintained per the Manual for Erosion and Sediment Control of Georgia, latest edition. Payment will constitute full compensation for all costs associated with silt fence, including installation, maintenance, repair, and removal.
  3. Inlet Sediment Trap (Sd2)- Bid Item 2-S-1240: Measurement for payment will be per each (EA) for inlet sediment traps suitably installed and maintained per the Manual for Erosion and Sediment Control of Georgia, latest edition. Payment will constitute full compensation for all costs associated with inlet sediment traps at existing storm water inlet structures, including installation,

maintenance, repair, and removal. Contractor shall be responsible for installing the number of sedimentation traps to adequately capture silt, thus minimizing silt leaving construction sites.

4. Temporary Stream Crossing, Maximum 40' Span (Sr) - Bid Item 2-S-1285: Measurement for payment will be per each (EA) for temporary stream crossings suitably installed, maintained and removed per the Manual for Erosion and Sediment Control of Georgia, latest edition. Payment will constitute full compensation for all costs associated with temporary stream (creek) crossings, each up to 40 foot span as measured from top of bank to top of bank, and shall include all necessary materials and labor to install, maintain, remove and dispose per the Drawing Detail 8/GC-2 and Section 02125. Cost of aggregate, pipe and concrete supports shall be included under this item and not in any other bid items.
  - I. Flowable Fill - Bid Item 2-X-1410: Measurement for payment will be per cubic yard (CY) complete in-place and accepted. Payment will constitute full compensation for furnishing and installing controlled low strength flowable fill concrete in accordance with Specification Section 03300 – Concrete Work, including labor, materials, equipment and any miscellaneous formwork (if required).

## **2.03 SEWER COLLECTIONS**

- A. Sewer Collections, PVC Gravity Pipe (Replace), 18" to 24" Diameter, All Depth Categories; Open Cut - Bid Items 4-A-5120, 4-A-5220, 4-A-5320, 4-A-5124, 4-A-5224, 4-A-5324: Measurement for payment will be per linear foot (LF) of pipe for gravity sewer replacement open cut measured from inside face of manhole to inside face of manhole. Depth of cut shall be the average depth of the pipeline as measured from the pipe invert to the existing ground level at the upstream and downstream manhole. Payment will constitute full compensation for all costs including but not limited to all labor, equipment, transportation, tools, dewatering, bypass pumping, pavement saw-cutting, excavation, removal and disposal of excavated material if replaced with imported material per Section 02200, existing pipe removal and disposal (size and material may vary), pipe bedding and haunching, pipe to manhole connections, pipe cutting, rebuilding existing manhole inverts and pipe beveling as required for a complete installation of new piping in accordance with Section 02730. No additional payment will be made for replacement of defective materials. No separate payment will be made for cutting or beveling pipe. All associated costs for air testing, post-installation cleaning (if required), and post-installation CCTV inspection for quality control shall be included under this item. Payment may be withheld due to failure to submit all post-installation CCTV video and other required quality control documentation for the work. No separate payment

shall be made for survey work performed by or for the Contractor in the establishment of reference points, bench marks, cut sheets, limits of rights-of-way or easement, including their restoration, as well as centerline or baseline points. Traffic control measures for work in low-traffic/residential areas shall be included in the unit price. Traffic control measures required for work in high-traffic/commercial areas will be paid when authorized by the Engineer (see Paragraph 2.01(C) above).

- B. Add/Deduct Cost for Providing 18” and 24” DIP in lieu of RCP Pipe - Bid Items 4-A-5166 and 4-A-5366: Measurement for payment will be per linear foot (LF). Payment will constitute full compensation for the additional/reduced (whichever applies) material and labor cost for furnishing and handling ductile iron pipe (DIP) instead of PVC pipe for open cut replacement, when directed to do so by the Engineer. All associated costs for pipe installation, equipment, air testing, material testing, post-installation cleaning (if required), post-installation CCTV inspection for quality control, post-installation infiltration testing, and related procedures and materials necessary shall be included in Open Cut bid items and not included herein. No additional payment will be made for replacement of defective materials.
- I. Sewer Manholes, 48” Diameter, 0’ to 10’ Depth, Pre-Cast Concrete – Bid Item 4-B-1048: Measurement for payment will be per each (EA). Payment will constitute full compensation for all costs for installing new pre-cast concrete manholes complete in accordance with Section 02491 and Section 02730. The unit price bid shall include but not be limited to excavation, manhole bedding, base, riser section(s), cone, anti-flotation measures (if required), chimney, frame, cover, steps, sealant, flexible piping connections, invert, bench(s), trough, connecting the pipes to the manhole, backfill and manhole vacuum testing. Traffic control measures for work in low-traffic/residential areas shall be included in the unit price. Traffic control measures required for work in high-traffic/commercial areas will be paid when authorized by the Engineer (see Paragraph 2.01(C) above).
- J. Sewer Manhole, Manhole Frame and Cover (Replace), 24” to 36” Dia., All Types - Bid Items 4-B-1510: Measurement for payment will be per each (EA). Payment will constitute full compensation for costs for replacing manhole frames and covers including, but not limited to labor, equipment, transportation, tools, pavement removal/disposal/replacement, and all other related procedures and materials necessary to produce the results specified in Section 02491 – Rehabilitation of Sanitary Sewer Manholes. Contractor will advise the Engineer in writing in the daily report identifying each manhole with replaced frame and cover. Traffic control measures for work in low-traffic/residential areas shall be included in the unit price. Additional traffic control measures required for work in high-traffic/commercial areas will be paid for separately when authorized by the Engineer (see Paragraph 2.01(C) above).

## 2.04 SEWER COLLECTIONS – LATERALS AND CLEANOUTS

- A. Exposed Service Lateral Reconnect 4"-6" Diameter, Any Depth, Up to 16 LF - Bid Items 4-C-1010, 4-C-1012 4-C-1014 and 4-C-1016: Measurement for payment will be per each (EA). Payment will constitute full compensation to re-connect services which have been excavated & exposed in conjunction with open cut mainline replacement, pipe-bursting and external point repair work. Payment for each service re-connection will include tee or wye fitting, tee insert or saddle connection installed on the mainline, replacement of up to 16 linear feet LF of service lateral pipe to accommodate mainline upsize or change in horizontal/vertical alignment, including replacement service line fittings, any additional excavation or pavement saw-cutting, bedding, and backfilling in accordance with the requirements Sections 02200, 02725, 02730 and 02735. All associated costs for testing, post-installation cleaning (if required), and post-installation CCTV inspection for quality control shall be included under this item. Payment may be withheld due to failure to submit all post-installation CCTV video and other required quality control documentation for the work. No separate or additional payment will be provided in the event the City directs the contractor to install ductile iron piping or fittings for the service piping reconnection if the sewer main is designated for future liner installation or conditions warrant provision of ductile iron piping material.
- B. Sewer, Cleanout, Install at ROW on Private Service - Bid Item 4-C-3010: Measurement for payment will be per each (EA). Payment will constitute full compensation to install a two-way cleanout at the edge of right-of-way or easement boundary complete (including riser piping, cleanout box and/or accessories, cleaning (if necessary), testing and restore the service laterals operation in accordance with Sections 02730, 02735 and Drawing Details. The cleanout shall incorporate all appropriate and necessary couplings to both the service connection and house connection. A cleanout shall be installed in conjunction with ALL service lateral replacements to edge of right-of-way.

## 2.05 SEWER COLLECTIONS – INTERNAL PIPE INSPECTION AND CLEANING

- A. Sewer, Internal Pipe Inspection, 6" to 24" Diameter - Bid Item 4-I-1050: Measurement for payment will be per linear foot (LF) from center of manhole to center of manhole. Payment will constitute full compensation to perform an internal closed circuit television (CCTV) sewer pipe inspection on sewers to be rehabilitated or replaced. No defect coding is required; however, header data and coding of service lateral locations is required. There will be no separate payment made for data delivery. Costs shall include, but not be limited to, labor, equipment, transportation, setup, tools, and all other related procedures and materials necessary to complete the inspections in accordance with Section 02752 – Internal Sewer Condition

Assessment. This item DOES NOT include post CCTV quality control inspection for sewer rehabilitation and replacement work. The cost for post CCTV quality control inspection for sewer rehabilitation and replacement work is to be included in the price of the respective sewer rehabilitation or replacement bid item. Payment shall only be made for the footage of sewer that is inspected commencing with zero footage at the portal of the pipeline associated with the manhole. If a pipe must be repaired before inspection can continue, then that repair will be paid for under the appropriate point repair bid items. Traffic control measures for work in low-traffic/residential areas shall be included in the unit price. Traffic control measures required for work in high-traffic/commercial areas will be paid when authorized by the Engineer (see Paragraph 2.01(C) above).

- B. Sewer, Internal Cleaning - Bid Items 4-L-1014: Measurement for payment will be per linear foot (LF) for the size classification category of sewer acceptably cleaned. Payment will constitute full compensation for sewer cleaning, including but not limited to labor, equipment, transportation, tools, and all other related procedures and materials necessary to produce the results specified in Section 02511 – Preconditioning and Cleaning Manholes and Sewers. Sewers will be cleaned to remove debris or obstructions found in sewers that impede or prohibit the rehabilitation or upsize of sewers, or when directed by the Engineer. All sewer cleaning debris shall be collected and removed from the line through the manhole by bucket, suction, or other means. Sewer cleaning DOES NOT include any special or additional surface preparation that may be required for certain rehabilitation methods (chemical wash, etc.). The cost for additional surface preparation is to be included in the price of the respective sewer rehabilitation bid item. Traffic control measures for work in low-traffic/residential areas shall be included in the unit price. Traffic control measures required for work in high-traffic/commercial areas will be paid when authorized by the Engineer (see Paragraph 2.01(C) above).

## 2.06 SEWER COLLECTIONS – PIPEBURSTING

- A. Sewer, Replacement with HDPE Using Pneumatic or Static Pipe-bursting Methods, All Depths (All Diameters) – Bid Items 4-S-1210: Measurement for payment will be per linear foot (LF) of sewer that is replaced by bursting. Payment will constitute full compensation for replacing existing gravity sewer mains with HDPE piping as indicated using pneumatic or static pipe-bursting methods. The unit price bid shall include but not be limited to furnishing of material, installation, equipment, stringing pipe, bypass pumping, lateral reconnection pit excavation, shoring, backfill, removal and disposal of excavated material if replaced with imported material per Section 02200, installing pipe, lubrication, connecting pipes, rebuilding existing manhole wall and invert, air testing, material testing, post-

installation cleaning (if required), post-installation CCTV inspection for quality control, and all other related procedures and materials necessary to complete pipe-bursting in accordance with Section 02725. Payment may be withheld due to failure to submit all post-installation CCTV video and other required quality control documentation for the work. No payment shall be made for any portion of pipe-bursting attempts which fail and result in use of other replacement methods such as open cut. If a section of existing pipe must be otherwise replaced, then that section will be paid for only by the appropriate conventional pipe work/ point repair bid item. Traffic control measures for work in low-traffic/residential areas shall be included in the unit price. Traffic control measures required for work in high-traffic/commercial areas will be paid when authorized by the Engineer (see Paragraph 2.01(C) above).

- B. Pipeburst Launch Pits (All Depths) - Bid Items 4-S-5005: Measurement of payment will be per vertical foot (VF). Payment shall include dewatering, excavation and backfill of pits required for replacing gravity sewer by pipe bursting. Depth of cut (VF) for excavation of pit shall be measured from the installed pipe invert to existing ground level at pipe centerline of horizontal alignment. The unit price shall also include installation and removal of appropriate trench stabilization equipment.
- C. Pipeburst Receiving Pits (All Depths) - Bid Items 4-S-5020: Measurement of payment will be per vertical foot (VF). Payment shall include dewatering, excavation and backfill of pits required for replacing gravity sewer by pipe bursting. Depth of cut (VF) for excavation of pit shall be measured from the installed pipe invert to existing ground level at pipe centerline of horizontal alignment. The unit price shall also include installation and removal of appropriate trench stabilization equipment.

## **2.07 SEWER COLLECTIONS – MICROTUNNELLING**

- A. Sewer, Microtunneling (All Diameters) – Bid Items 4-T-5412: The Contractor will be paid for constructing gravity sewer by horizontal directional drilling, including, but not limited to, orientation session for Owner and Engineer personnel, installation of equipment, stringing pipe, lubrication, installing pipe, deflection (circularity) testing, post-construction CCTV inspection for quality control, and all other related procedures and materials necessary to complete horizontal directional drilling in accordance with Section 02247 – Horizontal Directional Drilling. Measurement for payment shall be made for the linear foot length of installed pipe from inside face of manhole to inside face of manhole. No payment shall be made for any portion of directional drilling attempts that fail and other methods are used such as open cut excavation. Traffic control measures for work in low-traffic/residential areas shall be included in the unit price. Additional traffic control measures required for work in high-traffic/commercial areas will be

paid for separately when authorized by the Engineer (see Paragraph 2.01(D) above).

- B. Microtunneling Launch/Receive Pits (All Depths) - Bid Items 4-T-7410: Contractor will be paid for excavation and backfill of pits required for replacing gravity sewer by microtunnel in accordance with Section 02247. Depth of cut (VF) for excavation of pit shall be measured from the installed pipe invert to existing ground level at pipe centerline of horizontal alignment. The unit price shall also include installation and removal of appropriate trench stabilization equipment.

## **2.07 SEWER COLLECTIONS – JACK & BORE**

- A. Sewer, Replacement with DIP Using Jack & Bore Method, All Depths (All Diameters) – Bid Items 2-I-8420, 2-I-8442, 2-I-9605, and 2-I-9615: Measurement for payment for jack and bore or tunnel installations will be on a per linear foot (LF) basis for each location for boring and jacking a steel casing and installing the pipeline therein or constructing a tunnel and installing the pipeline therein at the location and between the limits as shown and detailed on the Drawings and as specified herein and accepted by the Engineer.
- B. Payment of the unit price established in the Bid Schedule for each jack and bore or tunnel installation will be full compensation for all labor, materials, equipment and incidentals required to complete the installation between the limits as shown and detailed on the Drawings.
- C. Payment of the unit price established in the Bid Schedule shall include all costs to complete the installation by either method.
- D. Payment of the unit price established in the Bid Schedule for each installation shall include furnishing and installing the steel casing pipe including spacers, or excavation and tunnel construction and all additional work and materials required for the completion of the crossings including furnishing and installing carrier pipe inside the casing or tunnel, annular fill, casing or tunnel end plugs, surface settlement monitoring, all excavation (including rock excavation), sheeting and bracing, dewatering and drainage, cleaning and testing of the pipe, backfill, cleaning the site, sodding and seeding as applicable, and for all else incidental thereto for which separate payment is not provided under other items in the Bid Schedule.
- E. Payment shall fully reimburse the Contractor for cooperating with and meeting all the requirements of the Georgia Department of Transportation and the affected railroads relative to construction as may be required or necessary to complete the crossings.

- F. Payment shall also be full compensation for excavation, backfill and compaction of jacking and receiving shafts and all steel sheeting left in place for the installation as specified.

## **2.08 SEWER COLLECTIONS - ABANDONMENT/CAP & PLUG/REMOVAL**

- A. Sewer, Abandon (grout fill) Existing Sewer Line in Place, All Diameters - Bid Item 4-X-1012: Measurement for payment will be per linear foot (LF). Payment will constitute full compensation for existing sewer abandonment by grout filling the existing sewer line in place. Measurement shall be based on the volume of grout installed compared with calculated volume of pipeline as directed by the Engineer. The unit price bid shall include, but not be limited to all costs for material, labor, equipment, bulkheads, vent piping and other miscellaneous items as required for a complete installation. Traffic control measures for work in low-traffic/residential areas shall be included in the unit price. Traffic control measures required for work in high-traffic/commercial areas will be paid when authorized by the Engineer (see Paragraph 2.01(C) above).
- B. Sewer, Cut & Plug Existing Sewer Line (All Diameters) – Bid Items 4-X-2009: Contractor will be paid for cutting and/or plugging the existing sewer line in place. The plug shall not extend more than 2 ft into the pipe being abandoned. Measurement shall be based on the number of sealed ends properly constructed to facilitate the grout filling of abandoned pipes. Payment shall be made at the unit price for each pipe end acceptably sealed with grout or mortar, including brick, concrete or other block inserts used to back the mortar plug. Provision of an air relief tube necessary to allow grout filling of the abandoned pipe and sealing the air relief tube after grouting shall be included in the price. Traffic control measures for work in low-traffic/residential areas shall be included in the unit price. Additional traffic control measures required for work in high-traffic/commercial areas will be paid for separately when authorized by the Engineer (see Paragraph 2.01(D) above).
- C. Remove & Dispose of Existing Sewer Line, Including Excavtion, Backfill, and Restoration, 0-10' Depth, All Sizes - Bid Item 4-X-3014: Demolition of sewers will be paid for each existing manhole demolished. Payment will include all costs associated with excavation, removal of existing pipe, compacted backfill, and proper disposal of manhole materials. Abandonment of connecting pipe(s) (if required) and flow control/bypass pumping will be paid for as separate items. Measurement for payment shall be made per linear feet (LF). Traffic control measures for work in low-traffic/residential areas shall be included in the unit price. Additional traffic control measures required for work in high-traffic/commercial areas will be paid for separately when authorized by the Engineer (see Paragraph 2.01(D) above). Payment for soils testing will be made separately by the City.



- D. Abandon & Fill Existing Manhole, 0-10' Depth, All Sizes - Bid Item 4-X-4030: Abandonment of existing manholes will be paid for each existing manhole abandoned up to 10 feet deep, all manhole sizes. Payment will include all costs associated with the excavation, removal and disposal of the top of each manhole to a depth of 5 feet below grade, plugging of all pipe penetrations, filling remaining structure with flowable fill concrete grout, compacted backfill, and proper disposal of contaminated excavation materials. Measurement for payment shall be made from the top of the manhole frame and cover to the invert at the outgoing pipe (VF). Traffic control measures for work in low-traffic/residential areas shall be included in the unit price. Additional traffic control measures required for work in high-traffic/commercial areas will be paid for separately when authorized by the Engineer (see Paragraph 2.01(D) above). Payment for soils testing will be made separately by the City.

## 2.09 RESTORATION

- A. Asphalt Pavement Patch – Sewer Trench Section - Bid Item 6-A-1410: Measurement for payment will be per square yard (SY) of pavement removed and replaced. Payment will constitute full compensation for removal and disposal of existing pavement and placement of new pavement including restoration of existing pavement markings as required for pipeline trench work, pits and service lateral excavations in streets not to exceed the paving limits indicated on Detail G-7 Type III Pavement Replacement in Section 02575. The unit price shall include, but not be limited to, labor, equipment, materials, transportation, and tools required to perform the work in accordance with the Drawings and Specifications. No additional payment will be made for removing and replacing adjacent pavement damaged in performance of the sewer rehabilitation and replacement work. Traffic control measures for work in low-traffic/residential areas shall be included in the unit price. Traffic control measures required for work in high-traffic/commercial areas will be paid when authorized by the Engineer (see Paragraph 2.01(C) above). Payment for soils testing and concrete shall be made separately by the City.
- B. Concrete and Granite, Curb and Gutter - Bid Item 6-E-2410: Measurement for payment will be per linear foot (LF) of curb removed and replaced. Payment will constitute full compensation for removing and replacing existing curb and gutter as necessary to complete the sewer rehabilitation or replacement work. Replacement of granite curbs and gutters shall be installed in accordance with the Drawing Detail 15/GC-2 and Section 02532 for Concrete Curbs and Gutters. Traffic control measures for work in low-traffic/residential areas shall be included in the unit price. Traffic control measures required for work in high-traffic/commercial areas will be paid when authorized by the Engineer (see Paragraph 2.01(C) above).

- C. Concrete Sidewalk - Bid Item 6-F-3410: Measurement for payment will be per square yard (SY) of concrete sidewalk removed and replaced. Payment will constitute full compensation for removing and replacing a public or private sidewalk in accordance with the Drawings and Section 02530 – Concrete Walks. Traffic control measures for work in low-traffic/residential areas shall be included in the unit price. Traffic control measures required for work in high-traffic/commercial areas will be paid when authorized by the Engineer (see Paragraph 2.01(C) above).
- D. Tree Restoration (Any Type Except Pine) - Bid Item 6-T-1015: Measurement for payment will be per each (EA). Payment will constitute full compensation for removing and replacing trees conflicting with the replacement or rehabilitation work on the sewer, whether on public or private property. Replacement may include removal and replanting, or replacing with a new tree (as directed by the Engineer), provision of tree survey, arborist support and arborist tree removal permit in accordance with Section 02112 –Route Clearing and Section 02900- Landscaping.
- E. Native Bush Restoration on Private Property – up to 36” Diameter – Bid Item 6-T-5110: Measurement for payment will be per each (EA) bush removed and replaced for either native or ornamental types. Payment will constitute full compensation for removing and replacing bushes on private property. Replacement may include removal and replanting, or replacing with a new bush (as directed by the Engineer) in accordance with Section 02900 - Landscaping.
- F. Seeding – Bid Item 6-U-2450: Measurement for payment will be per square yard (SY). Payment will constitute full compensation for fine grading, fertilizing and seeding previously landscaped areas on public or private property in accordance with Section 02900 – Landscaping. Grass seeding shall match in kind the existing adjacent grass of previously landscaped areas. Soil preparation and/or topsoil shall be included.

## 2.10 ALLOWANCES

- A. Allowances specified in the Bid Schedule are to establish a fund to pay the cost of items for which the City could not establish accurate quantities and/or detailed scope of work. This work shall be completed only at the written direction of the Engineer, and the cost of such work shall be approved prior to performance of the work.
- B. The Contractor shall be responsible for the payment for these services to the appropriate payee providing such service, and shall submit evidence

of payments to the Engineer prior to its inclusion in the progress payments.

- C. Payment will be made for invoices submitted by the Contractor subject to the Contract Documents. Contractor will not receive any additional compensation for bond or insurance costs for work executed using allowance funding.
- D. Allowance allocations shall only be paid to the Contractor for completed work authorized by the Engineer. All allowance dollar amounts not expended shall revert to the City at the completion of the project. Should the final allowance costs be less than the specified amount of the allowance the Contract will be adjusted accordingly by change order. The amount of change order will not recognize any changes in handling costs at the site, labor, overhead, profit and other expenses caused by the adjustment to the allowance item.
- E. Allowances have been included in the contract in accordance with Section 01380 for the following:
  - 1. Owner Controlled Contingency – Bid Item 9-Z-2410: An allowance has been established as the value of this item. This allowance shall be used to pay for miscellaneous work to be accomplished at the direction of the Engineer. It shall include items of work consistent with and related to the project which are not shown on the plans but which may be necessary to the successful completion of the Agreement. It is expected that work under this item will be accomplished utilizing construction items established under the other sections of these specifications. All work performed under this section shall comply with the various sections of these specifications which are appropriate to the specific items involved. No work will be allowed under this section without the prior written approval of the Engineer. . This work shall be further described, by the Engineer, in written form and/or on modifications to the drawings or on supplemental drawings. This allowance may be used to pay the costs, where the amounts are determined as specified in General Condition Article GC-42, and as directed by the Engineer.
  - 2. Material Testing – Bid Item 9-Z-2480: An allowance has been established as the value of this item. This allowance provides for soil, concrete, asphalt and other testing services which verify the required quality and/or workmanship of the Work as required by the Engineer or Specifications. Refer to Sections 01380 and 01410 for testing requirements. This allowance may be used to pay the costs, where the amounts are determined as specified in General Condition Article GC-42, and as directed by the Engineer.

3. City Directed Site Restoration (Private & City Properties) – Bid Item 9-Z-4450: An allowance has been established as the value of this item. This allowance is provided for site restoration work on private property outside the scope of the bid items. Site restoration shall only be performed where private property has been damaged during the course of the work, not due to contractor negligence.
  
4. City Directed Additional Work – Bid Item 9-Z-4460: An allowance has been established as the value of this item. This allowance is provided for related sewer utility work to be performed in conjunction with this project at the direction of the City. All work performed under this section shall comply with the various sections of these specifications and industry standards which are appropriate to the specific items involved. This work shall be further described, by the Engineer, in written form and/or on modifications to the drawings or on supplemental drawings. In any event, no work will be allowed under this section without the prior written approval by the City.

**PART 3 – PRODUCTS (NOT USED)**

**PART 4 – EXECUTION (NOT USED)**

**END OF SECTION**

---

**SECTION 01310****Scheduling the Work****PART 1 – GENERAL****1.01 SCOPE**

- A. This section describes the scheduling and progress reporting requirements of the Contract. The primary objectives of the requirements of this Section are:
1. To assist the City and Engineer in evaluating the progress of the Work;
  2. To provide for optimum coordination and sequencing of the Work by the City, Contractor and any related work or services provided by other parties which may affect the Project.
  3. To permit the timely prediction or detection of events or occurrences that might affect the timely prosecution of the Work.
- B. The Contractor shall be required to attend a 1-day training/mentoring session on the use of the Primavera scheduler software, provided by a Primavera Authorized Trainer. The Contractor shall provide the training session (fee for the Primavera Authorized Trainer) and Primavera training manuals for each participant as needed. The training session shall be held at the Evans Technology, Roswell, Georgia facility and shall be attended by the Contractor's scheduler(s). The Contractor shall be responsible for the cost of training for additional members of their firm or future retraining, as may be deemed necessary by the Contractor.

**1.02 GENERAL SCHEDULING REQUIREMENTS**

- A. The Work of this Contract shall be planned, scheduled, executed, and reported using the critical path method (CPM). Through the Project Control Tools bid item, the Contractor shall purchase and use the following software program to develop its Schedule Submittal:
1. Primavera Engineering and Construction, version to be specified by the Engineer
- B. A comprehensive schedule shall be developed by the Contractor and submitted to the Engineer for review prior to commencement of said Work. Upon acceptance by the Engineer, the schedule will be merged into the City's overall schedule.

- C. The schedule shall be structured on an asset basis (manholes and sewers). The asset identification (ID) numbers are assigned by the City of Atlanta through its geographic information system (GIS). There may be numerous work activities for each asset, depending on the Contractor's choice for work break down, however, each activity must include standard attributes or associated codes as defined in the table below. Separate fields or attributes shall be provided for each activity as illustrated below to enable the City and Engineer to coordinate with the community and others by use of a centralized planning/ scheduling system.

### Activity Codes:

Required	Activity Code	Example	
		Code Value	Description
X	* Area Management District (T13 Global)	North	North Area:
X	Asset Location (T13 Global)	Easement	Asset requires Easement for Access
X	* Contract Number (T13 Global)	3006007989	FC-3006007989 Sewer Group 1 - Rehabilitation - Pipe Bursting Phase 2 Contract A1
X	Contractor (T13 Global)	IWPC	Inland Waters Pollution Control
X	* Council District (Global)	1	Council District 1
X	House Number (T13 Global)	82	82
X	* Neighborhood Planning Unit (Global)	C	NPU C
X	Permit (T13 Global)	1	Utility Permit - Lane Closure
X	Pipe Diameter (T13 Global)	12	Pipe Diameter: 12-inches
X	Priority (Global)	Y	Yes
X	Rehabilitation Method (T13 Global)	REP	Open Cut Replacement
X	* Sewer Basin (GLOBAL)	South River	South River Basin
X	Street Name (T13 Global)	Aaron Street NW	Aaron Street, NW
X	Structure: From Location (T13 Global)	13850200701	Sewer Group 1 \ Sewershed: UT01BX
X	Structure: To Location (T13 Global)	13850200701	Sewer Group 1 \ Sewershed: UT01BX
	Structure: TEMP. MH From Location (T13)		
	Structure: TEMP. MH To Location (T13)		
X	* WBS AC Lvl 01 (T13)	04	Rehabilitate Sewer System
X	* WBS AC Lvl 02 (T13)	04.16	Sewer Group 1
X	* WBS AC Lvl 03 (T13)	04.16.212	Sewer Group 1 - Rehabilitation - Phase 2 - Pipe Bursting \ Contract A1
X	* WBS AC Lvl 04 (T13)	70	Construction
X	* WBS AC Lvl 05 (T13)	70	Construction

\* = Do Not Modify these activity codes values, or descriptions.

- D. At a minimum, the schedule shall include the activities for each rehabilitated asset (sewer pipeline or manhole) as deemed appropriate to clearly illustrate and document the Work. The activities listed below are repetitive for the same type of rehabilitation when organized on an asset basis and generally considered standard industry practice. This set of

standard activities will be used to harmonize multiple rehabilitation contracts by the City and shall not be revised or in text or grouping without approval from the Engineer.

### Planning & Administrative Activities by Contract Type:

Description	Contract Type
Bond & Insurance Submittal	ALL
Product Submittals	ALL
Permits	ALL
Right of Entry Acquisition	REHAB
72 Hour Disruption Notice	REHAB
Door Hanger Notification	REHAB
Application for Payment Submission	ALL
Application for Payment Review	ALL
Project Record Submittals	ALL
Project Closeout Document Submittals	ALL

### Construction Activities by Rehabilitation Type:

Description	Rehab Type
Pre-Construction Survey	ALL
Locate Existing Utilities	PB, Open Cut, HDD
Install Access Road	ALL
Install/ Maintain/ Remove Traffic Control	ALL
Install/ Maintain/ Remove Bypass Pumping	ALL
Pre-CCTV Existing Pipeline	CIPP, HDD, PB
Rehabilitate Service Laterals	CIPP, PB, HDD, Open Cut
Precondition Existing Pipeline	CIPP
Install Liner/ Reinstate Services	CIPP
Install Launch Pit/ PB / Reinstate Services	PB
Install New Pipeline/ Reinstate Services	Open Cut, HDD
Post CCTV Review	CIPP, PB
Post CCTV Submission to COA	CIPP, PB
Manhole Rehabilitation	MH
Test New Installation	ALL
Site Restoration	ALL
Pavement Replacement	ALL
Asphalt Pavement Milling & Topping	PAVMT

**Milestones by Contract Type:**

Description	Contract Type
Contract Execution	ALL
Notice to Proceed	ALL
Pre-construction Meeting	ALL
(" ") Public Information Meeting	ALL
Trial Test Methodology Acceptance	ALL
Sewershed (" ") Substantial Completion	ALL
Sewershed (" ") Final Completion	ALL
Contract Substantial Completion	ALL
Contract Final Completion	ALL

- E. The Contractor shall typically report progress by sewershed and rehabilitation method.
- F. The Schedule Submittal, as defined herein, shall represent the Contractor's commitment and intended plan for completion of the Work in compliance with the Contract completion date and interim milestone dates specified. The Schedule Submittal shall take into account all foreseeable activities to be accomplished by any separate consultants or the City, and interface dates with utility companies, the City's operations, and others. The Schedule Submittal shall anticipate all necessary manpower and resources to complete the Work within the dates set forth.
- G. Once reviewed and accepted by the Engineer, the Schedule Submittal will become the Schedule of Record.
- H. The Contractor is responsible for determining the sequence of activities, the time estimates of the detailed reconnaissance/investigative and rehabilitation activities, as well as the means, methods, techniques and procedures to be employed. The schedule shall clearly indicate the proposed sequence of work within each sewershed. The Schedule of Record shall represent the Contractor's best judgement of how it will execute the Work in compliance with the Contract requirements. The Contractor shall ensure that Schedule of Record is current and accurate and is properly and timely monitored, updated and revised as Project conditions and the Contract Documents may require.
- I. The City will work with the Contractor to assign and schedule the work in a logical and efficient manner. However, all items in this contract shall be priced such that each item can be assigned independently or combined at the City's sole discretion, in regards to both quantity and scope. There shall be no consideration of any claim for extra payment arising from a decision by the City to assign potential work items under this contract in any combination or in combination with another contract utilizing alternate technologies.



### 1.03 SCHEDULE SUBMITTALS

- A. The Contractor shall submit the qualifications of the scheduler(s) proposed to be used on the project immediately after NTP. The scheduler(s) is subject to the approval of the Engineer. The Contractor shall use the services of a scheduler(s) who has verifiable training and credentials in preparing and maintaining a computerized CPM Construction Schedule using Primavera software as specified herein. The qualifications of the scheduler(s) should be a minimum of 4 years experience in project scheduling for civil, structural, architectural, or related engineering disciplines. The scheduler(s) should have direct experience developing, maintaining, updating, modifying project schedules utilizing Primavera products, ideally Primavera Engineering and Construction. The cost for providing a qualified scheduler(s) shall be included in the Project Control Tools bid item.
- B. Within 30 days from receipt of Notice to Proceed, a baseline/comprehensive schedule shall be submitted by the Contractor to the Engineer for approval. The Contractor shall submit the complete schedule in electronic format as directed by the Engineer. At a minimum, the schedule output shall include the following:
1. Activities with attributes or codes
  2. Estimated activity durations in working days. (Not to exceed 15 working days for the construction activities.)
  3. All logic ties
  4. The critical path activities differentiated from other activities
  5. All activities for submittal of shop and working drawings, videos, test results, procurement, fabrication, delivery, installation and testing of critical materials.
  6. Related activities shall be grouped on the network diagram
  7. A time scale located at the top and/or bottom of the network diagram showing calendar days and months
  8. Earliest start date
  9. Earliest finish date
  10. Actual start date
  11. Actual finish date
  12. Latest start date
  13. Latest finish date
  14. Calendar Definition
  15. Total float
  16. All constraints
  17. Lag – No lag is allowed in the baseline/ comprehensive schedule
  18. Monetary value of activity (from Schedule of Values)

- C. The Contractor shall participate in a review and evaluation of the baseline schedule with the Engineer. Any revisions necessary as a result of this review shall be resubmitted to the Engineer within 10 calendar days after the conference. The mutually acceptable schedule shall then be used by the Contractor for planning, organizing and directing the work and for reporting progress. If the Contractor desires to make changes in its method of performing the Work, he shall notify the Engineer in writing stating the reason for the changes.
- D. The Contractor shall demonstrate competence in the use of CPM scheduling through the submission of a fully compliant CPM Construction Schedule with the initial CPM submission. In the event the Contractor fails to provide a baseline schedule in a timely manner or fails to demonstrate competence in the CPM scheduling, the Engineer may direct the Contractor to employ the services of a Scheduling Firm that can demonstrate competence. The Contractor shall comply with such directive at no additional cost to the City.
- E. Each activity shall be coded using the following format:
- xxxx.yyyyyy
- Where xxxx is the last four digits of the contract number (FC #), and yyyyyy is for the Contractor's use according to a template provided by the Engineer at the pre-construction conference.
- F. Activities and milestones to appear on the Schedule Submittal shall include, but not be limited to, City reviews that impact the Work, negotiation for Rights of Entry, Easement delineation, obtaining required permits, sitework, paving, submittals, renewal/rehabilitation and testing by pipe segment, coordination requirements, and dates of Substantial and Final Completion.
- G. The Engineer shall have the right to require the Contractor to modify any portion of the Contractor's Schedule Submittal, or Recovery Schedule, as herein required, (including cost loading) with the Contractor bearing the expense thereof, which the Engineer reasonably determines to be:
1. Impractical or unreasonable
  2. Based upon erroneous calculations or estimates
  3. Required to ensure proper coordination by the Contractor of the Work of its subconsultants and with the work or services being provided by any separate consultants
  4. Necessary to avoid undue interference with the City's operations
  5. Necessary to ensure completion of the Work by the milestone and completion dates set forth in the Contract Documents

6. Required in order for the Contractor to comply with the requirements of this Section or any other requirements of the Contract Documents
  7. Not in accordance with the Contractor's actual operations
- H. The electronic version of the schedule shall be submitted on a floppy computer disk or CD-R, in a form and format acceptable to the Engineer, including all required submission information resident in the computer system and containing all of the files associated with the schedule.
- I. Each week the Contractor will provide the Engineer and Public Information (PI) Office with a detailed 2 week look-ahead schedule. The schedule must be in the format required by the PI Office.

#### **1.04 UPDATING OF THE SCHEDULE / PROGRESS REPORTS**

- A. The Engineer shall review the Contractor's report of actual progress at each progress meeting. Prepared by the Contractor, said report shall set forth up-to-date and accurate progress. The Contractor in consultation with all principal subconsultants shall prepare said report. The Contractor will perform a complete schedule update on a monthly basis or at the discretion of the Engineer.
1. The Contractor shall submit the updated schedule in electronic format as directed by the Engineer. The Contractor shall submit hard copies of the schedule output including, but not limited to:
    - a. 30-day Look-ahead Report including but not limited to planned activities within the next thirty days
    - b. Milestones to be completed
  2. The Contractor shall provide written explanation of all changes in activity durations, relationships, and constraints with the schedule output. Changes will require written approval by the Engineer.
- B. The Schedule Report of the Contractor shall show the activities, or portions of activities, completed during the reporting period, the actual start and finish dates for these activities, remaining duration and estimated completion dates for activities currently in progress.
- C. At the progress meeting a total review of the Project will take place including but not limited to, the following:
1. Current update of the Schedule of Record in format as prescribed by Engineer

2. Anticipated detailed construction activities for the subsequent report period
  3. Critical items pending
  4. Contractor requested changes to the Schedule of Record
- D. The Contractor shall submit a narrative with the progress report which shall include, but not be limited to, a narrative describing actual Work accomplished during the reporting period, a description of problem areas, current and anticipated delaying factors and their impact, explanations of corrective actions taken or planned, any proposed newly planned activities or changes in sequence, and proposed logic for a Recovery Schedule, if required, as further described herein.
- E. No invoice for payment shall be submitted and no payment whatsoever will be made to the Contractor until the Schedule of Record, and narrative reports as defined herein, are updated.

#### **1.05 SCHEDULE REVISIONS**

- A. Should the Contractor desire to or be otherwise required under the Contract Documents to make modifications or changes in its method of operation, its sequence of Work or the duration of the activities in the Schedule of Record, it shall do so in accordance with the requirements of this Specification Section and the Contract Documents. The approved Schedule of Record may only be revised by written approval of the Engineer as provided herein.
- B. The Contractor shall submit requests for revisions to the Schedule of Record to the Engineer using the Schedule Revision Form provided by the Engineer. The Contractor shall identify revisions and description of logic for rescheduling work and substantiate that the milestone and completion dates will be met as listed in the Contract Documents. Proposed revisions acceptable to the Engineer and City will be approved in writing and incorporated into the Schedule of Record.
- C. Requests for revision will be accompanied by evidence acceptable to the Engineer that the Contractor's subcontractors are in agreement with the proposed revisions.
- D. If there are separate consultants on the Project, the approval of the separate consultants shall be obtained to make the proposed schedule revisions. If accepted by the Engineer and City, the revisions shall be binding upon the Contractor and all separate consultants on the Project.

- E. The impact of all change orders to this Contract shall be included in the project schedule.

## 1.06 RECOVERY SCHEDULE

- A. Should the updated Schedule of Record, at any time during the Contractor's performance show that, in the sole opinion of the Engineer, the Contractor is behind schedule for any milestone or completion date for any location or category of work, the Contractor, at the request of the Engineer, shall prepare a Schedule Revision for the purpose of displaying recovery. The revision shall identify how the Contractor intends to reschedule its Work in order to regain compliance with the Schedule of Record within thirty (30) calendar days.
- B. The Contractor shall prepare and submit to the Engineer a one month maximum duration Recovery Schedule, incorporating the best available information from subconsultants, subcontractors and others which will permit a return to the Schedule of Record at the earliest possible time. The Contractor shall prepare a Recovery Schedule to the same level of detail as the Schedule of Record. The Recovery Schedule shall be prepared in coordination with other separate consultants on the Project.
- C. Within two (2) calendar days after submission of the Recovery Schedule to the Engineer, the Contractor shall participate in a conference with the Engineer to review and evaluate the Recovery Schedule. Within two (2) calendar days of the conference, the Contractor shall submit the revisions necessitated by the review for the Engineer's review and acceptance. The Contractor shall use the accepted Recovery Schedule as its plan for returning to the Schedule of Record.
- D. The Contractor shall confer continuously with the Engineer to assess the effectiveness of the Recovery Schedule. As a result of these conferences, the Engineer will direct the Contractor as follows:
  - 1. If the Engineer determines the Contractor continues behind schedule, the Engineer will direct the Contractor to prepare a Schedule Revision and comply with all of the requirements of a Schedule Revision as stated herein and the other requirements of the Contract Documents; provided, however, that nothing herein shall limit in any way the rights and remedies of the City and Engineer as provided elsewhere in the Contract Documents; or
  - 2. If the Engineer determines the Contractor has successfully complied with provisions of the Recovery Schedule, the Engineer will direct the Contractor to return to the use of the approved Schedule of Record.

## 1.07 FLOAT TIME

- A. Float or slack time shown on the currently approved Schedule of Record is not for exclusive use or benefit of either the City or the Contractor and is available for use by either of them according to whichever first needs the benefit of the float to facilitate the effective use of available resources and to minimize the impact of Project problems, delays, impact, acceleration or changes in the Work which may arise during performance. The Contractor specifically agrees that float time may be used by the City in conjunction with their review activities or to resolve Project problems. The Contractor agrees that there will be no basis for any modification of the milestone or completion dates or an extension of the Contract Time, or a claim for additional compensation as a result of any Project problem, delay, impact, acceleration, or change order which only results in the loss of available float on the currently approved Schedule of Record. Unless otherwise stated herein, float as referenced in these documents, is total float. Total float is the period of time measured by the number of working days each non-critical path activity may be delayed before it and its succeeding activities become part of the critical path. If a non-critical path activity is delayed beyond its float period, that activity then becomes part of the critical path and controls the end date of the project. Thus, the delay of the non-critical path activity beyond its float period will cause delay to the project itself.
- B. Float time shown on the Schedule of Record shall not be used arbitrarily by the Contractor in a manner which, in the opinion of the Engineer, unnecessarily delays separate subcontractors from proceeding with their work in a way which is detrimental to the interests of the City. Liability for delay of the project completion date rests with the party actually causing delay to the project completion date. For example, if Party A uses some, but not all of the float time and Party B later uses the remainder of the float time as well as additional time beyond the float time, Party B shall be liable for the costs associated with the time that represents a delay to the project's completion date. Party A would not be responsible for any costs since it did not consume all of the float time and additional float time remained, therefore, the project's completion date was unaffected.

END OF SECTION

---

**SECTION 01320**

**CONSTRUCTION PHOTOGRAPHY**

**PART 1 GENERAL**

**1.01 SCOPE**

- A. The Contractor shall furnish all labor, equipment and materials required to provide the Owner with digital construction photography of the Project as specified herein.
- B. The Contractor shall provide for professional videos and photographs to be made prior to and after construction to provide documentation of conditions and aid in any damage claims assessment. All conditions which might later be subject to disagreement shall be shown in sufficient detail to provide a basis for decisions.
- C. Video and photo files shall become the property of the Owner and none of the video or photographs herein shall be published without express permission of the Owner.

**1.02 PRE AND POST CONSTRUCTION PHOTOGRAPHY**

- A. Prior to the beginning of any work, the Contractor shall provide for professional videos and photographs of the work area to record existing conditions.
  - 1. The Contractor shall furnish a complete videotaped record of the pipeline route. The videotape shall include the date of taping and shall contain audio commentary to emphasize existing conditions along the entire route.
  - 2. The route shall be videotaped prior to beginning of construction. The Contractor shall furnish three sets of compact disks containing the videotaped data to the Engineer.
  - 3. The route shall also be videotaped at the completion of construction when directed by the Engineer. The videotape shall show the same areas and features as in the preconstruction videos. The Contractor shall furnish three sets of compact discs containing the videotaped data to the Engineer.
- B. The pre-construction videos shall be submitted to the Engineer within 15 calendar days after receipt of construction Notice to Proceed by the Contractor. Post construction videos and photographs shall be provided prior to final acceptance of the project.

### **1.03 PROGRESS PHOTOGRAPHS**

- A. Photographs shall be taken to record the general progress of the Project during each pay period. Photographs shall be representative of the primary work being performed at the time.
- B. All photographs shall be taken with a digital camera. The photographs shall include the date and time marking in the digital record. All photographs shall be labeled on a tab connected to the bottom of the photo to indicate date and description of work shown.

## **PART 2 PRODUCTS**

### **2.01 PHOTOGRAPHS**

- A. Photography and video files shall be provided in CD-ROM format.
- B. Photographs shall also be provided in hard copy format. The photographs shall include the date and time marking on the photograph. All photographs shall be labeled on a tab connected to the bottom of the photograph. Tab label shall contain:
  - 1. Project name.
  - 2. Orientation of view.
  - 3. Description of work shown.
- C. All compact disks (CDs) furnished under this section shall be suitable for viewing with Windows Media Player.

## **PART 3 EXECUTION**

### **3.01 SUBMITTALS**

- A. No construction shall start until pre-construction photography has been completed and accepted by the Engineer.
- B. A minimum of ten 8 x10-inch progress photographs shall be submitted with each application for payment. The view selection will be as determined by the Engineer. Photographs shall be submitted in Print File Archival Preservers, 8 1/2 x 11-inch plastic sleeves pre-punched for a 3-ring binder.
- C. Construction photographs shall be submitted with each payment request. Failure to include photographs may be cause for rejection of the payment request.



- D. The Contractor shall be responsible for all discrepancies not documented in the pre-construction videos and photography.

**+++ END OF SECTION 01320 +++**

---

**SECTION 01350****Project Document Tracking and Control System****PART 1 – GENERAL****1.01 SCOPE**

- A. The Contractor shall utilize the City of Atlanta's Project Document Tracking and Control System (DTCS). The primary function of the system is to facilitate timely processing and approval of all contract documentation in coordination with the overall Project Schedule established by these Specifications and the Contractor. The City will identify the specific system to be utilized for document tracking and control and Lynx Photo Management software. The DTCS will:
1. Facilitate communication among the Owner, Engineer and Contractor;
  2. Facilitate turn-around time with regard to responses and approvals;
  3. Provide a central location for all Project information to facilitate all Project participants in performing their tasks based on the latest Project data;
  4. Provide a standard system of project administration with accountability.
- B. The Contractor shall be required to utilize the web-based DTCS system that resides on the Department of Watershed Management server to generate documents in the proper format for submission to the City. The Contractor shall access the system through the internet using a compatible web browser from the Contractor's administrative field office location, and/or other locations where work associated with the Project is being performed.
- C. The Contractor shall be required to generate Project documents and records utilizing the aforementioned system. The Contractor shall be required to transmit and submit the Project documents within the system to the City.
- D. The Contractor shall utilize a high capacity scanner capable of scanning 11 x 17 documents, double sided, on site for the entire duration of the Project. All documents must be scanned in and attached to the appropriate DTCS document, including submittals, shop drawings, O&M's and all other documents requested by the Engineer.

- E. The Contractor shall utilize the DTCS to create and maintain Project documents, including, but not limited to the following:
1. Company Directory: Addresses, Phone Numbers, Personnel Contacts, etc.
  2. Drawings Log: Current Drawing revision log
  3. Submittals (Integrated with Project Schedule through Activity codes)
  4. Transmittals
  5. Requests for Information and Answers (RFIs)
  6. Change Documents, Including:
    - a. Requests for Proposal (RFPs)
    - b. Work Authorizations (WAs)
    - c. Change Order Requests (CORs)
    - d. Change Orders (CO)
    - e. Design Clarifications (DC)
  7. Daily Reports (Daily Diaries)
  8. Field Decisions & Clarification Memos
  9. Notice of Non-Compliance
  10. Construction Issue Memos
  11. Punchlists
  12. Meeting Minutes & Agendas
  13. Correspondence
  14. Work Plans
  15. Start-up Plans

- 16. Equipment Operation and Maintenance Training
- 17. Spare Parts

F. The Contractor shall utilize the complete capabilities of the DTCS to meet the requirements of this Section. The Contractor shall provide a highly trained and experienced construction project controls person knowledgeable in construction work sequencing, productivity, scheduling and application of the DTCS. This person, along with the Contractor's management team, shall work closely with the City to deliver the documents outlined in this Section

G. Software Support

The Contractor is to provide for a one day training class in the base bid for the Lynx PM software for ten (10) personnel, seven (7) for City of Atlanta and three for the Contractor. The type of class to be determined by the City. The Contractor may contact Lynx PM Representative at 1-877-955-7711.

The Contractor shall be required to establish an internet connection using DSL or better to connect to the DTCS to permit the forwarding and receipt of documents.

a. The DTCS will support the following Email programs, and the Contractor is to utilize:

- (1) Microsoft Outlook 2003
- (2) Microsoft Outlook 2007

H. The Contractor shall be required to attend a 2-day training session on the operation of the City's DTCS. The training session shall be attended by the Contractor (limited to three participants) as well as representatives of the Owner (seven participants). The Contractor shall be responsible for the cost of training for additional members of their firm or future retraining, as may be deemed necessary by the Contractor.

I. The Contractor shall meet with the City within 15 days after the Contract is awarded to discuss access requirements and the Contractor's plan to utilize DTCS and execute the document control functions herein.

J. Access through the internet to the DTCS shall be operational within 30 days following the pre-construction meeting date. This must be

operational from the contractor's administrative field office location.

## **1.02 COMPANY DIRECTORY**

The Contractor and the City will monitor and manage the Company Directory. The directory must include Company name, Company abbreviation, contact names, address, phone numbers and e-mail addresses.

## **1.03 DRAWING LOG**

The City will maintain a log of initial "issued for construction" drawings in the DTCS. Information shall include drawing number, title and revision number. In addition to logging the initial project drawing list, the City will maintain a log on the DTCS of all subsequent revisions to these drawings and any sketches resulting from clarification memos, RFIs, field orders and Change Orders. It is the Contractor's responsibility to utilize the latest drawings and sketches in the performance of the work.

## **1.04 SUBMITTALS/SHOP DRAWINGS**

- A. Requirements: This section specifies supplemental requirements to GC-28, related to the processing of submittals and shop drawings. The Contractor will utilize the DTCS to log and track submittals, as well as generate associated transmittal letters.
- B. Submittals & Product Data: A list of all required submittals will be entered into the DTCS by the Contractor. Submittals shall be incorporated into packages, with the submittal numbering format to be provided by the COA's engineer. The Contractor will log and track all submittals utilizing the DTCS. Each review cycle shall be entered into the DTCS. The Contractor shall identify as activities in the CPM schedule, specified in SC-16, to include all data submittals, as well as those involving complex reviews and long lead deliveries, and all procurement items required for construction activities. Submittal schedule information shall be updated monthly with the Contractor's updated project CPM schedule, as specified in SC-16.
- C. Samples: A list of all required sample submittals will be entered into the DTCS by the Contractor. Sample submittals shall be identified as individual submittals within the submittal packages with numbering as specified above.
- D. Guarantees/Warranties: A list of all required Guarantee/Warranty submittals will be entered into the DTCS by the Contractor. These submittals shall be identified as individual submittals within the submittal packages with numbering as specified above.

- E. Work Plans, Start-up Plans, O&M Submittals and Spare Parts: All testing, Start-up and O&M submittals will be entered into the DTCS by the Contractor. These submittals shall be identified as individual submittals within the submittal packages identified with numbering as specified above.
- F. Submittal Procedures: The Contractor shall prepare all submittal packages utilizing the submittal numbering system, description and packaging conventions described above. Submittals prepared by the Contractor, which fail to follow the conventions described above, will be returned “amend and resubmit”. Should the Contractor determine that a submittal is required and is not covered by the listing within the DTCS, consultation with the City to determine the submittal number, description and packaging will be required.

### **1.05 CORRESPONDENCE**

The City shall monitor and manage the correspondence, Non-Compliance Notices, Field Decisions & Clarification Memos and Construction Issue Memo logs. The Contractor is responsible for generating Project correspondence within the DTCS, and forwarding the correspondence to the City.

### **1.06 TRANSMITTAL LOG**

The Contractor and the City will monitor and manage the transmittal log. All Project transmittals shall be created electronically, automatically sequentially numbered and logged into the DTCS system as they are created. The Contractor is responsible for utilizing the system to create transmittals for items transmitted to the Owner, Engineer, Resident Inspection Staff and other Contractors.

### **1.07 REQUEST FOR INFORMATION & ANSWERS**

The Contractor shall be responsible for generating RFIs on the DTCS system. The Contractor shall notify the City when an RFI is submitted. The City will monitor and manage the RFI log. The City will generate an Answer document in response to each RFI and forward them to the Contractor. The DTCS will track “Ball in Court” for all RFIs and Answers, as well as date of original generation and response date. In addition the RFIs will reference the relative Specification Section and Drawings. The DTCS will identify the date of the request and the originator, responsible party for a response and the date of the response.

### **1.08 CHANGE DOCUMENTS**

Change documents include Request for Information (RFIs), Work Authorization

Requests (WARs), Work Authorizations (WAs), Change Orders Requests(CORs), Design Clarifications (DCs), and Change Orders (COs). All change documents will be monitored and managed by the City utilizing the DTCS. The DTCS will track “Ball in Court” status of all change documents.

### **1.09 DAILY REPORTS**

The Contractor is responsible for creating daily reports (daily diaries) utilizing the DTCS. The Contractor is required to enter the Daily Reports into the DTCS by 10:00 a.m. of the subsequent day that the Contractor or any subcontractor performs work. All daily reports shall be logged into the DTCS by the Contractor. The Contractor shall also provide one signed hard copy of all daily reports on a weekly basis. Required information shall include Contractor, Date, Day, Temperature, Precipitation, Sky, Wind, Work Activity, Equipment, Field Force, Visitors, Materials, and Scheduled Activities utilizing the Primavera schedule activity codes. Daily reports which fail to link work activities to the active Primavera schedule will not be acceptable.

### **1.10 PUNCLISTS**

The City will monitor and manage Punchlists, and will create Punchlists to be forwarded to the Contractor. The Contractor shall address the punchlist items that have been assigned to the Contractor and forward updates to the City. Once accepted as complete, the City will access the punchlist in the DTCS and close it out.

### **1.11 MEETING MINUTES AND AGENDA**

The City shall monitor and manage the meeting minute process. The City will forward meeting minutes to the Contractor electronically. The City will log the meeting minute items into the DTCS within three (3) days of the meeting date.

### **1.12 PROGRESS PAYMENTS /REQUISITIONS FOR PAYMENT**

The Contractor is responsible for creating progress payment applications directly from the DTCS and then forwarding them to the City electronically along with hard copies by 4:00 p.m. at the end of each update/billing period. The Contractor shall also simultaneously provide a separate submittal of the updated progress schedule (P6 or latest version at the time of purchase), as specified in SC-16. All Progress Payments and schedule of values shall be developed as defined in the Special Conditions. Required information within the Pay Application shall be coordinated with the City’s Project Manager. Maintenance of the “As Built” record documents by the Contractor shall be verified before processing will be approved. Failure of a Contractor to maintain project record

documents, maintain current and properly prepared daily reports or to submit the project schedule update per SC-16 will be just cause for withholding of the monthly or final payment.

### **1.13 LYNX PHOTO MANAGEMENT SOFTWARE**

The Lynx PM software shall be utilized by the City and the Contractor for the duration of the project. The daily construction photographs will be the permanent visual record of the pre-construction conditions, daily construction site activities, and the completion of construction work. The Contractor must submit to the City no less than four (4) record photos for each activity ID listed in the project schedule per the last schedule update. Applicable photos must accompany each Pay Application.

\*\*\* END OF SECTION 01350 \*\*\*



[This page intentionally left blank]

---

**SECTION 01351**

**Public Involvement**

**PART 1 - GENERAL**

1.01 SCOPE

- A. The Contractor shall provide all personnel, services, and materials as specified under this Section necessary to meet the requirements and responsibilities related to the Public Involvement and Public Relations and Outreach as specified hereinafter, during performance of Work under the Agreement by the Contractor.
- B. Unless specifically stated otherwise within the Agreement, no separate payment will be made for satisfying Public Involvement requirements.

**PART 2 - PRODUCTS (NOT USED)**

**PART 3 - EXECUTION**

3.01 PUBLIC INFORMATION KICK-OFF MEETING

Prior to commencement of Work under the Agreement and following the Preconstruction Meeting, the Contractor, the Project Manager (PM), Construction Manager (CM), Public Information Manager (PIM), Public Information Officer (PIO), and the City's Engineer will be required to attend a public information meeting hosted by the DWM Office of Communications and Community Relations. At this meeting the Contractor's responsibilities will be discussed, the relationship with the OCCR, the City's Engineer and/or designated representative of the City. The Contractor and staff will also be advised as to the expectations of the City regarding citizen relations and inquiries, as well as public notification protocols.

3.02 DOOR-HANGERS

- A. The Contractor shall produce door hangers required for notice to customers/citizens and residents from the template provided by the City's PIM as specified hereinabove in paragraph 3.02. Door hangers shall be utilized for notification in the event of, but not limited to, the following events:
  - 1. Planned service disruption/outages
  - 2. Road closures/detours/traffic pattern changes
  - 3. Access/entrance to property

4. Work start-up
5. CCTV
6. Smoke Testing
7. Dye Testing

### 3.03 IMPACTED AREA ADDRESS DATABASE

- A. The Contractor shall provide the Office of Communications and Community Relations with a database of addresses and phone numbers (and names if available) of all project impacted residences, businesses and facilities at least three (3) weeks prior to project start-up. The database will be used by the City's PIO for regular citizen communications and notifications.
- B. The Contractor and Engineer shall copy the City's PIO on all correspondence with citizens and property owners.

### 3.04 CUSTOMER SERVICE TRACKING SOFTWARE

- A. The Contractor shall use the City's Project Management Software to track and enter information from customers/citizens regarding complaints, claims and inquiries. All related information shall be updated on a daily basis. Tracking information and responses shall be coordinated with the City's PIO. Reports shall be provided as weekly updates on all activities and on specific cases within twenty-four (24) hours when requested.
- B. Information recorded shall include but not be limited to the following:
  1. Date complaint/claim/inquiry received.
  2. Name, address and telephone number of individual filing complaint/claim/inquiry.
  3. Nature of complaint/claim/inquiry.
  4. Address where problem is located if different than above.
  5. Action required, date, action taken, date action completed.
  6. Follow-up with person who filed under 2 above to verify satisfaction or status.
  7. Documents associated with actions taken.
  8. Any information regarding resolution with the Contractor's, Subcontractor's or Vendor's Insurance Company shall be fully documented.

### 3.06 IDENTIFICATION BADGES AND SECURITY

- A. All members of the Contractor's staff and his subcontractor's permanent staff at or above the level of foreman who will be working on-site will be issued an ID badge by the City. The ID badge will list the worker's name and company Affiliation and will include a picture.
- B. A template will be provided by the PIM and shall be returned to the Office of Security and Safety when updated with the above information for signature by the Director of Security and Safety.
- C. It shall be the Contractor's responsibility to collect the ID badges from any employee who is discharged or resigns prior to completion of the project as well as at completion of the project. The Contractor shall return all ID badges to the Office of Security and Safety within 48 hours of their collection. The Contractor will be charged a fee of **\$25.00** per badge for any badge not returned at completion of the project. For any ID badges lost during the term of the project that must be reissued, there will be a charge of **\$15.00** per ID badge. The Contractor shall deduct these charges from his periodic or closeout payment request or the City will deduct.
- D. Since lower level personnel of the Contractor, Subcontractor or Vendor will not be issued ID badges, the Contractor must maintain a daily sign-in sheet for daily workers under his supervision. The Superintendent must be able to identify any employee on the site as a bona fide worker if asked and if not able to identify, the Engineer will direct the Superintendent to remove the individual from the site. The Contractor and Subs or Vendors will provide a program of temporary ID badges and/or laminated on-site passes that must be cross-referenced to each day's employee time card/payroll sheet with unique employees' numbers. Any employee that will be on the Project over thirty (30) days will be issued a picture ID with the employee number prominently shown. Any employee possessing an ID badge must wear that badge visibly at all times on the Project. The Contractor is responsible for maintaining a safe "drug-free" work environment.
- E. The Contractor shall develop a Security Plan for use on the job site during construction. The Plan shall encompass as a minimum such topics as the use of pre-employment background checks for specific project staff, drug tests, crime prevention and anti-theft procedures, workplace violence and methods to secure project documents. All staff working on the site shall be familiar with the requirements of the Security Plan.
- F. City Ordinances prohibit the carrying of weapons on City streets. The City of Atlanta Police Department will be notified of any person bringing weapons to the jobsite; they will be removed immediately and prosecuted.
- G. All of the Contractor's staff at or above the level of foreman shall attend a 4-hour mandatory CMG Security Training session conducted by the Office of Security and Safety. Multiple training sessions will be offered and staff must complete the

training at least within 1 month of commencing work on the jobsite. All costs associated with the training will be considered as incidental to the Contract.

- H. Persons on the jobsite shall report any suspicious activity by workers or by others at the jobsite area first to the Project Management, and/or Atlanta Police Department by calling 911 and immediately to the Director of Security and Safety.

### 3.07 SCHEDULE

- A. The Contractor shall provide the City's PIO with a copy of the detailed project schedule following approval by the Engineer.
- B. Bi-weekly, the Contractor shall provide a list of properties:
  - 1. That will be affected by the Contractor's activities within the upcoming 4 weeks;
  - 2. Where work is ongoing in the right of way in front or in the back of the property;
  - 3. Where site restoration activities are ongoing.
- C. The Contractor shall inform the City's PIO through the weekly progress meetings and in writing of any project schedule changes or changes in "disruptive work" such as blasting, road closures, etc., that would have significant impact on citizens or require prior citizen notification. The Contractor shall notify the City's PIO of any "disruptive" activities affecting the public that occur on the jobsite within 4 hours of their occurrence.

### 3.08 MAPS

The Contractor will provide the assigned City's PIO with a map of each project area assigned by task order, including the proposed and existing sewer overlays. The map will include property lines and addresses, so the Contractor can identify the areas of impacted properties.

### 3.09 MEDIA RELATIONS AND JOB SITE INQUIRIES

- A. As specified above in paragraph 3.01, only authorized persons shall release any information to media inquiries. The Contractor's field personnel shall at all times have project information cards available that will be provided to media and citizens if inquiries are made on-site. All inquiries shall be directed to the person referred to on the card and citizens shall be referred to the DWM Project Hotline telephone number (404-546-3200) and the [www.Atlantawatershed.org](http://www.Atlantawatershed.org) website
- B. Project information cards shall be produced by the Contractor from the template provided by the DWM Office of Communications and Community Relations. Final language to be included on the Project Information Card will be provided.

### 3.10 VEHICLES SIGNS & PROJECT SITE SIGNAGE

- A. The Contractor shall place the COA logo, project name, Help line number, and website address on all magnetic vehicle signs specified in Specification Section 01580. Vehicle signs shall be installed on all vehicles used for Work on this project. A signage template will be provided by the DWM Office of Communications and Community Relations and produced by the Contractor.
- B. Note: The cost for the production, installation and maintenance of the signs will be paid for through the respective unit price bid items, in accordance with specification Section 01580.
- C. All project sites shall have pre-approved project signs which read in accordance with the Template provided as part of the Special Conditions Signs shall be produced by the Contractor. Some of the signs shall be mounted on moveable skids so they can be relocated as the project progresses on various streets in the basin. Sizes will vary, but all will be smaller than the 96"x 48" size project signs shown. Size shall be as directed by the Engineer. Contractor shall provide a minimum of 1 project sign per work location. The sign is required in addition to the four City of Atlanta Project signs identified in the Special Conditions.

### 3.11 NOTIFICATIONS

- A. The Contractor shall provide the following notifications to the City's PIO and the City's PIM to facilitate communication to affected citizens through automated phone message or mailers:
  1. Anticipated work start date-must be three (3) weeks prior so the City's PIO may send out two (2) week notice mailer.
  2. Service disruptions-notify the City's PIO at least 72 hours in advance so that 48-hour notice automated phone message notice may be issued.
  3. Street Closure or Partial Closure-notify the City's PIO at least 72 hours in advance to permit 48-hour automated phone message.
  4. Significant work in neighborhood- blasting, directional drilling, trenchless installation, smoke testing, dye testing, open cut, etc.-notify the City's PIO at least 72 hours in advance to permit 48-hour automated phone message.
- B. The Contractor shall provide the following door hanger notifications and the manpower to deliver them at a minimum:
  1. Service disruptions- notice to citizens 24 hours prior to disruption.
  2. Street Closure or Partial Closure - notify fire, police other emergency services and other authorities 24 hours prior to street closure.

3. Significant work in neighborhood- blasting, directional drilling, trenchless installation, open cut, etc.-notify citizens via door hangers 24 hours in advance.
- C. The Contractor shall be fully responsible for notification to all emergency related services for detours, closures (partial or full) or traffic pattern changes and as such they must be detailed in their traffic control plan and implemented through the Contractor's Traffic Control Manager and per all permitting requirements.
- D. The Contractor shall be fully responsible for distributing all notifications a minimum of 48 hours in advance of service outages for schools, nursing homes, hospitals, medical clinics, assisted living facilities or other types of facilities. Contractor shall also make personal contact with facility representatives no later than 60 minutes prior to the outage.
- E. The Contractor shall at all times coordinate with the City's Office of Communications and Community Relations and Call Center to provide detailed schedules and street locations for service disruptions or street closures to ensure that Call Center is well equipped to provide adequate response to citizen inquiries.

### 3.12 RESPONSES AND RESOLUTION OF CITIZEN INQUIRIES

- A. Customer Service Tracking Software: The Contractor shall use the City's Project Management Software to enter status information and track inquiries related to the project. The City Call Center attendant shall create the initial file and enter information for resident and property owner complaints and/or claims. This information shall be updated on daily bases. Tracking information and responses shall be coordinated with the Contractor and City's PIO.
- B. When a City of Atlanta's Call Center attendant informs the Contractor of a citizen inquiry or complaint, the Contractor shall respond immediately to the call center if the inquiry is related to an emergency situation. If the inquiry is general, the contractor's response is required within 24 hours to the call center with an update on the resolution status. The citizen's name date and time of call and complaint shall be documented and tracked by the Contractor using the City's Project Management Software database, which will assign a complaint tracking number. The complaint information will be transmitted to the Contractor and PIO within 24 to 48 hours. The citizen will receive a follow-up call from the call center with the status information on the resolution of the problem within 24 hours, and additional follow-up calls until the problem is resolved.
- C. Unresolved inquiries will be reviewed at project progress meetings. At this time, the City's PIO will review open inquiries and the Contractor's Representative will facilitate follow-up on resolution.

### 3.13 RESOLUTION OF COMPLAINTS AND CLAIMS

Failure of the Contractor to resolve any legitimate complaint or claim filed resulting from the work performed under this contract, following notice in accordance with the contract agreement, may result in resolution of the complaint or claim by the City. The Contractor will be charged for the associated cost in accordance with the applicable sections of the contract. No additional payment will be made to the Contractor for any costs associated with complaint or claim resolution, same being incidental to the various contract items which are bid. Failure to manage the issues and items adequately to minimize public complaints and impacts will be cause for increasing the retainage, withholding payment and/or Notice and Termination of the Contractor cause if more than 10% of the noticed complaints or claims age past 30 days without decisive resolution and scheduling of recovery work.

### 3.14 PROJECT UPDATES

The Contractor will provide monthly project updates regarding significant progress, notable changes, and any consent decree milestones to be used by the DWM Office of Communications and Community Relations staff to update the Atlantawatershed.org website, project materials, monthly and quarterly reports.

### 3.15 RIGHTS OF ENTRY AND ACCESS TO PRIVATE PROPERTY

- A. The Contractor is required to coordinate with the Office of Engineering Services Land and Easement Group regarding obtaining Rights of Entry and related agreements with the property owner(s) to access or work outside of the City's existing easements or rights of way or any agreements related to property restoration , as may be necessary for the Work or at the convenience of the Contractor. Such coordination shall include the following:
1. Maintaining a contact log with, but not limited to, all: contact names, addresses and phone numbers; all attempts (with date, name, and notes of conversation) via telephone, in person, or via written correspondence. The Contractor must maintain copies of all written correspondence with the property owner(s) and/or tenant(s), and provide the City with Copies, if directed by the City or already required as part of this Section;
  2. Assuming responsibility relating to the private property access and any agreements reached between the Contractor and the Property Owner;
  3. Taking any other steps as reasonably necessary to adequately protect the interests of Contractor, the private property owner and the City with respect to the accessing the City's existing easement areas;



- B. The Contractor is required to work within the City's existing easement areas and rights of way at all times; however, at the Contractor's convenience and if agreed upon between the Contractor and the Property Owner the Contractor may follow a route other than along the City's right of way alignment . In such case, the Contractor must have a written agreement with the Property Owner to document the terms and conditions of the Work and/or property restoration, which shall be subject to the City's review and approval. Any such agreement shall be at the Contractor's expense.
- C. The Contractor must identify all parcels requiring access or Work associated with the project, including parcels owned by: CSX, Norfolk Southern, Georgia Power, Fulton County, DeKalb County, Atlanta Housing Authority, MARTA, Schools, or City owned parcels under the purview of another department, within the first 30 days after the NTP has been officially delivered to the Contractor. Permits and agreements with such property owners to perform Work may be required as a condition of commencement of Work on properties owned by such entities. As such, Contractor shall cooperate with the City to negotiate and enter into appropriate agreements with such property owners prior to commencement of Work in a form acceptable to the City.
- D. The Contractor must identify all areas where the Contractor believes it is physically impossible to perform the work in the existing easement area within the first 30 days after the NTP has been officially delivered to the Contractor. If any such area exists, the Contractor must state in writing the property information (address and tax PIN), the work to be performed, and the reason they believe it is impossible to work within the easement area. If the City deems it is impossible to perform the work in the City's existing easement area and/or rights of way, the City will proceed with the acquisition of required temporary construction easement or other interests necessary to perform the Work. The City will make the ultimate decision regarding the ability or inability of the work to be performed within the existing easement area and shall provide such determinations in writing to the Contractor. In the instances for which formal acquisition processes must occur, Contractor shall take all available steps to prioritize work in other areas to avoid delays in overall project work. The City shall not be responsible for unapproved damage to private properties or deviations from the rights of way and/or easement areas for the convenience of the Contractor.
- F. Contractor must, in all dealings with private property owners concerning this type of access to their property, advise that the Contractor is an independent contractor and is not seeking or obtaining access to private property on behalf of the City. Contractor must include this advisement in all written communications with any private property owner, as well as all documents evidencing or relating to agreed access to private property. Contractor may at any time during the course of performing the Work request clarification of the City's existing easements and/or rights of way through an RFI process.

# ATTACHMENT A

## Citizens Comments Response

PROJECT #

PROJECT NAME:

### Basic Data

Contact ID:

First Name	Last Name	Council District / NPU			
<input type="text"/>	<input type="text"/>	<input type="text"/>			
Address	Number	Street Name	St, Ave, etc.	Apt. #	Zip
<input type="text"/>	<input type="text"/>	<input type="text"/>	<input type="text"/>	<input type="text"/>	<input type="text"/>
Home Phone	( ) -	Work Phone	( ) -		
<input type="text"/>	<input type="text"/>	<input type="text"/>	<input type="text"/>		
Email :	<input type="text"/>			Outside Project Area	Y___ N___
<input type="text"/>	<input type="text"/>			<input type="text"/>	<input type="text"/>
Notes:	<input type="text"/>				

### Comments / Complaints / Request

Comment Date	<input type="text"/>	Engineer needs to	Y___ N___
<input type="text"/>	<input type="text"/>	<input type="text"/>	<input type="text"/>
Comment / Complaint:	<input type="text"/>		

### Response

Response Date	<input type="text"/>	Is Follow-up Required	Y___ N___
<input type="text"/>	<input type="text"/>	<input type="text"/>	<input type="text"/>
Who Responded	<input type="text"/>		
Response Given:	<input type="text"/>		

Sewer Cleaning and Pipeline Assessment Contract

---

**SECTION 01400**

**QUALITY ASSURANCE/QUALITY CONTROL**

**PART 1 GENERAL**

**1.01 SCOPE**

- A. This section includes requirements for the implementation of the Contractor's quality assurance and quality control program.

**1.02 SITE INVESTIGATION AND CONTROL**

- A. Contractor shall check and verify all dimensions and conditions in the field continuously during construction. Contractor shall be solely responsible for any inaccuracies built into the Work due to Contractor's and subcontractor's failure to comply with this requirement.
- B. Contractor shall inspect related and appurtenant Work and report in writing to the Engineer any conditions that will prevent proper completion of the Work. Failure to report any such conditions shall constitute acceptance of all Site conditions, and any required removal, repair, or replacement caused by unsuitable conditions shall be performed by the Contractor solely and entirely at Contractor's expense.

**1.03 INSPECTION OF THE WORK**

- A. All work performed by the Contractor and subcontractors shall be inspected by the Contractor and non-conforming Work and any safety hazards in the work area shall be noted and promptly corrected. The Contractor is responsible for the Work to be performed safely and in conformance to the Contract Documents.
- B. The Work shall be conducted under the general observation of the Engineer and is subject to inspection by the City of Atlanta or representatives of the City acting on their behalf to ensure strict compliance with the requirements of the Contract Documents. Such inspection may include mill, plant, shop, or field inspection, as required. The Engineer or any inspector(s) shall be permitted access to all parts of the Work, including plants where materials or equipment are manufactured or fabricated.
- C. The presence of the Engineer, or any inspector(s), however, shall not relieve the Contractor of the responsibility for the proper execution of the Work in accordance with all requirements of the Contract Documents. Compliance is the responsibility of the Contractor. No act or omission on the part of the Engineer, or any inspector(s) shall be construed as relieving Contractor of this responsibility.

Inspection of Work later determined to be non-conforming shall not be cause or excuse for acceptance of the non-conforming Work. The City may accept non-conforming Work when adequate compensation is offered and it is in the City's best interest as determined by the City.

- D. All materials and articles furnished by the Contractor or subcontractors shall be subject to rigid documented inspection, by qualified personnel, and no materials or articles shall be used in the Work until they have been inspected and accepted by the Contractor's Quality Control representative and the Engineer or other designated representative. No Work shall be backfilled, buried, cast in concrete, covered, or otherwise hidden until it has been inspected. Any Work covered in the absence of inspection shall be subject to uncovering. Where uninspected Work cannot be easily uncovered, such as in concrete cast over reinforcing steel, all such Work shall be subject to demolition, removal, and reconstruction under proper inspection at the Contractor's expense.
- E. All materials, equipment and/or articles furnished to the Contractor by the City shall be subject to rigid inspection by the Contractor's Quality Control representative before being used or placed by the Contractor. The Contractor shall inform the Engineer, in writing, of the results of said inspections within one working day after completion of inspection. In the event the Contractor believes any material or articles provided by the City to be of insufficient quality for use in the Work, the Contractor shall immediately notify the Engineer.

#### **1.04 TIME OF INSPECTION AND TESTS**

- A. Samples and test specimens required under these Specifications shall be furnished and prepared for testing in ample time for the completion of the necessary tests and analyses before said articles or materials are to be used. The Contractor shall furnish and prepare all required test specimens at Contractor's own expense.
- B. Whenever the Contractor is ready to backfill, bury, cast in concrete, hide, or otherwise cover any Work under this Contract, the Engineer shall be notified not less than three work days in advance to request inspection before beginning any such Work of covering. Failure of the Contractor to notify the Engineer at least three work days in advance of any such inspections shall be reasonable cause for the Engineer to order a sufficient delay in the Contractor's schedule to allow time for such inspection. The costs of any remedial or corrective work required, and all costs of such delays, including its impact on other portions of the Work, shall be borne by the Contractor.

#### **1.05 SAMPLING AND TESTING**

- A. The Contractor shall retain and pay for an independent materials testing agency approved by the Engineer and the City of Atlanta as required by the General

Conditions. This independent testing agency will develop and submit a testing plan for quality assurance on each type of work activity. The testing agency will document the processes and procedures utilized to verify and maintain quality work. When not otherwise specified, all sampling and testing shall be in accordance with the methods prescribed in the most current standards, as applicable to the class and nature of the article or materials considered. However, the Engineer reserves the right to use any generally accepted system of inspection which, in the opinion of the Engineer, will ensure the Engineer that the quality of the workmanship is in full accord with the Contract Documents.

- B. The City reserves the right to abbreviate, modify the frequency of or waive tests or quality assurance measures, but waiver of any specific testing or other quality assurance measure, whether or not such waiver is accompanied by a guarantee of substantial performance as a relief from the specified testing or other quality assurance requirements as originally specified, and whether or not such guarantee is accompanied by a performance bond to assure execution of any necessary corrective or remedial work, shall not be construed as a waiver of any technical or qualitative requirements of the Contract Documents.
- C. Notwithstanding the existence of such waiver, the City shall reserve the right to make independent investigations and tests as specified in the following paragraph and failure of any portion of the Work to meet any of the qualitative requirements of the Contract Documents, shall be reasonable cause for the City to require the removal or correction and reconstruction of any such Work.
- D. In addition to any other inspection or quality assurance provisions that may be specified, the City shall have the right to independently select, test, and analyze, at the expense of the City, additional test specimens of any or all of the materials to be used. Results of such tests and analyses shall be considered along with the tests or analyses made by the Contractor to determine compliance with the applicable specifications for the materials so tested or analyzed provided that wherever any portion of the Work is discovered, as a result of such independent testing or investigation by the Engineer, which fails to meet the requirements of the Contract Documents, all costs of such independent inspection and investigation and all costs of removal, correction, reconstruction, or repair of any such Work shall be borne by the Contractor.

#### **1.06 CONTRACTOR'S QUALITY ASSURANCE/QUALITY CONTROL REQUIREMENTS**

- A. The Contractor shall establish and execute a Quality Assurance/Quality Control (QA/QC) program for the services that are being procured from the Contractor. The program shall provide the Contractor with adequate measures for verification and conformance to defined requirements by the Contractor's personnel and subcontractors (including fabricators and suppliers). This program shall be described in a Plan responsive to this Section. It shall utilize the services of an

independent testing agency/company that is industry certified to provide quality assurance and compliance with the standards specified.

- B. The Contractor shall furnish the Engineer a project specific QA/QC Plan. The Plan shall contain a comprehensive account of Contractor's QA/QC procedures as applicable to this job. The Contractor shall furnish for review by the Engineer, no later than 14 days after receipt of notice to proceed, the QA/QC plan proposed to be implemented. The plan shall identify personnel, procedures, control, instructions, tests, records, and forms to be used. Construction will be permitted to begin only after acceptance of the QA/QC Plan. The detailed requirements for this Plan are delineated in the following paragraphs. No payments will be made to the Contractor until the QA/QC Plan is fully accepted by the Engineer.
- C. The QA/QC Plan shall describe and define the personnel requirements described herein. The Contractor shall employ a full time on-site QA/QC Manager to manage, address and resolve all quality control issues.
  - 1. The QA/QC Manager shall be as identified by the Contractor and approved by the City. The QA/QC Manager shall have a minimum of five (5) years of construction experience in pipe line installation. The QA/QC Manager shall be onsite at all times while work is being performed by the contractor, to remedy and demonstrate that work is being performed properly and to make multiple observations of all Work in progress. This individual shall be dedicated solely to QA/QC activities and shall have no supervisory or managerial responsibility over the work force. The QA/QC Manager shall not be assigned any other duties or roles by the Contractor.
  - 2. The Contractor shall provide additional personnel who are assigned to assist the QA/QC Manager as required to fulfill the requirements of the QA/QC Plan. The Contractor shall provide a copy of the letter to the QA/QC Manager signed by an authorized official of the firm which describes the responsibilities and delegates sufficient authorities to adequately perform the functions of the QA/QC Manager, including authority to stop work which is not in compliance with the contract. The QA/QC Manager shall issue letters of direction to all other various quality control representatives outlining duties, authorities, and responsibilities. Copies of these letters shall also be furnished to the Engineer.
- D. The Contractor's QA/QC program shall ensure the achievement of adequate quality throughout all applicable areas of the Project. A customized QA/QC Plan shall be developed that discusses each type of work that the Contractor is responsible for within the Project. The QA/QC Plan shall describe the program and include procedures, work instructions and records and a description of the quality control organization.

1. The description of the quality control organization shall include a chart showing lines of authority staffing plan and acknowledgment that the QA/QC staff shall implement the system for all aspects of the work specified. The staffing plan shall identify the name, qualifications (in resume format), duties, responsibilities, and authorities of each person assigned a QA/QC function including the QA/QC Manager.
  2. In addition, the Plan shall describe methods relating to areas that require special testing and procedures as noted in the specifications.
- E. Identification and Control of Items and Materials: Procedures to ensure that items or materials that have been accepted at the site are properly used and installed shall be described in the QA/QC Plan.
- F. The procedures shall provide for proper identification and storage, and prevent the use of incorrect or defective materials.
- G. Inspection and Tests: The Contractor shall have written procedures defining a program for control of inspections performed and these procedures shall be described in the QA/QC Plan.
1. Inspections and tests shall be performed and documented by qualified individuals. At a minimum, "qualified" shall mean having performed similar QA/QC functions on similar type projects for a minimum of five (5) years and possession of industry standards certification and license. Records of personnel experience, training and qualifications shall be submitted to the Engineer for review and approval.
  2. The Contractor shall maintain and provide to the Engineer, within two working days of completion of each inspection and test, adequate records of all such inspections and tests. Inspection and test results shall be documented and evaluated to ensure that requirements have been satisfied.
  3. Procedures shall include:
    - a. Specific instructions defining procedures for observing all Work in process and comparing this Work with the Contract requirements (organized by specification section).
    - b. Maintaining and providing daily QA/QC inspection reports. Such reports shall, at a minimum, include the following:
      - i. Dated list of Item(s) inspected
      - ii. Location of the test sample(s)
      - iii. Logs, detailed locational drawings and confirmation reports
      - iv. Quality characteristics in compliance
      - v. Quality characteristics not in compliance
      - vi. Corrective/remedial actions taken



- vii. Statement of certification
  - viii. QC Manager’s signature
  - c. Specific instructions for recording all observations and requirements for demonstrating through the reports that the Work observed was in compliance or a deficiency was noted and action to be taken.
  - d. Procedures to preclude the covering of deficient or rejected Work.
  - e. Procedures for halting or rejecting Work.
  - f. Procedures for resolution of differences between the QA/QC representative(s) and the production representative(s).
  - g. Method of documenting QA/QC process and results including:
    - i. Automatic exception reporting
    - ii. Resolution tracking
    - iii. Quality Confirmation Test reports
    - iv. Sample retention index and storage
4. The QA/QC Plan shall identify all contractual hold/inspection points as well as any Contractor imposed hold/inspections points.
5. The QA/QC Plan shall include procedures to provide verification and control of all testing provided by the Contractor including:
- a. Individual test records containing the following information:
    - i. Item tested –item number and description
    - ii. Test results
    - iii. Test designation
    - iv. Test work sheet including location sample was obtained
    - v. Acceptance or rejection
    - vi. Date sample was obtained
    - vii. Retest information, if applicable
    - viii. Control requirements
    - ix. Tester signature
    - x. Testing QC staff initials
  - b. Maintaining and providing to the Engineer daily testing records. Such records shall, at a minimum, contain the following:
    - i. Dated list of Item(s) inspected
    - ii. Location of the test sample(s)
    - iii. Logs, detailed location drawings and confirmation reports
    - iv. Quality characteristics in compliance
    - v. Quality characteristics not in compliance
    - vi. Corrective/remedial actions taken
    - vii. Statement of certification
  - c. QC Manager’s signature providing for location maps/drawings (i.e. lift drawings, laying schedules, etc.) for all tests performed or location of Work covered by the tests.
  - d. Maintaining copies of all test results.
  - e. Ensuring Engineer receives independent copy of all tests.

- f. Ensuring testing lab(s) are functioning independently and in accordance with the specifications.
  - g. Ensuring re-tests are properly taken and documented.
- H. Control of Measuring and Test Equipment: Measuring and/or testing instruments shall be adequately maintained, calibrated, certified and adjusted to maintain accuracy within prescribed limits. Calibration shall be performed at specified periods against valid standards traceable to nationally recognized standards and documented.
- I. Supplier Quality Assurance: The QA/QC Plan shall include procedures to ensure that procured products and services conform to the requirements of the Specifications. Requirements of these procedures shall be applied, as appropriate, to subcontractors and suppliers. QA/QC inspections and certifications shall not be deferred to the Contractor’s subcontractors or suppliers.
- J. Deficient, Defective and Non-conforming Work and Corrective Action
  - 1. The QA/QC Plan shall include procedures for handling of deficiencies and non-conformances. Deficiencies and non-conformances are defined as documentation, drawings, material, and equipment or Work not conforming to the specified requirements or procedures. The procedures shall prevent non-conformances by identification, documentation, evaluation, separation, disposition and corrective action to prevent recurrence. Conditions having adverse effects on quality shall be promptly identified and reported to the senior level management. The cause of conditions adverse to quality shall be determined and documented and measures implemented to prevent recurrence. In addition, at a minimum, this procedure shall address:
    - a. Personnel responsible for identifying deficient and non-complying items within the work.
    - b. How and by whom deficient and non-compliant items are documented “in the field”.
    - c. The personnel and process utilized for logging deficient and non-compliant work at the end of each day onto a Deficiency Log.
    - d. Tracking processes and tracking documentation for Deficient and Non-Compliant items.
    - e. Personnel responsible for achieving resolution of outstanding deficiencies.
    - f. Once resolved, how are the resolutions documented and by whom.
- K. Special Processes And Personnel Qualifications
  - 1. The QA/QC Plan shall include detailed procedures for the performance and control of special process (e.g. welding, soldering, heat treating, cleaning, plating, nondestructive examination, etc.).

2. Personnel performing special process tasks shall have the experience, training and certifications commensurate with the scope, complexity, or nature of the activity. They shall be approved by the Engineer before the start of Work on the Project.

L. Audits

1. The Contractor's QA/QC program shall provide for documented audits to verify that QA/QC procedures are being fully implemented by the Contractor as well as its subcontractors. Audit records shall be made available to the Engineer upon request.
2. The Contractor shall provide to the City, a quarterly report indicating any outstanding and unresolved exceptions to the QA/QC program or contract documents. The report will include documentation on any standards modifications, corrections, failed tests and a review of field procedures and checks and balances effectiveness.

M. Documented Control/Quality Records

1. The Contractor shall establish methods for control of Contract Documents that describe how Drawings and Specifications are received and distributed to assure the correct issue of the document being used. The methods shall also describe how as-built data are documented and furnished to the Engineer.
2. The Contractor shall maintain evidence of activities affecting quality, including operating logs, records of inspections and tests, audit reports, material analyses, personnel qualification and certification records, procedures, and document review records.
3. Quality records shall be maintained in a manner that provides for timely retrieval, and traceability. Quality records shall be protected from deterioration, damage, and destruction. The Contractor shall maintain an automated exceptions list of any non-conforming or defective or substandard work.
4. The Contractor shall provide a list with specific records as specified in the Contract Documents which will be furnished to the Engineer at the completion of activities and in conjunction with logs and location drawings.

- N. Acceptance of QA/QC Plan: The Engineer's review and acceptance of the Contractor's QA/QC Plan shall not relieve the Contractor from any of its obligations for the performance of the Work. The Contractor's QA/QC staffing is subject to the Engineer's review and continued acceptance. The City, at its sole option, without cause, may direct the Contractor to remove and replace the

QA/QC representative. No Work covered by the QA/QC Plan shall start until the Engineer's acceptance of Contractor's QA/QC plan has been obtained.

- O. The Engineer may perform independent quality assurance audits to verify that actions specified in Contractor's QA/QC Plan have been implemented. No Engineer audit finding or report shall in any way relieve Contractor from any requirements of this Contract.

## **1.07 TESTING SERVICES**

- A. All tests which require the services of a laboratory to determine compliance with the Contract Documents shall be performed by an independent commercial testing firm acceptable to Engineer. The testing firm's laboratory shall be staffed with experienced technicians, properly equipped and fully qualified to perform the tests in accordance with the specified standards. All standard quality assurance testing and installation verification testing will be at the expense of the Contractor.
- B. Testing, when required, will be in accordance with all pertinent codes and regulations and with procedures and requirements of the American Society for Testing and Materials (ASTM).
- C. The Engineer shall have the right to inspect work performed by the independent testing laboratory both at the project and at the laboratory. This shall include inspection of the manual, equipment calibrations, proficiency sample performance, etc.).
- D. Testing services provided by the City, if any, are for the sole benefit of the City; however, test results shall be available to the Contractor. Testing necessary to satisfy Contractor's internal quality control procedures shall be the sole responsibility of Contractor.
- E. Testing Services Provided by the Contractor
  - 1. Unless otherwise specified, and in conjunction with, all other specified testing requirements, the Contractor shall provide the following testing services, and submit a detailed testing plan for each along with proposed forms for Engineer's review:
  - 2. Moisture-density and relative density tests on embankment, fill, and backfill materials.
  - 3. In-place field density test on embankments, fills and backfill.
  - 4. QC testing of all precast and/or pre-stressed concrete

5. All other tests and engineering data required for the Engineer's review of materials and equipment proposed to be used in the Work
6. In addition, the following QC tests shall be performed by the Contractor:
  - a. Holiday testing of pipeline and all other coatings systems applied to surfaces as required by the Engineer
  - b. Slumps, air bucket tests, compression tests and other confirmation tests
  - c. Air testing of field-welded joints for steel pipe or pipe cylinders and fabricated specials.
  - d. All testing and inspection of welding work including, but not limited to, welding procedure qualifications, welder operator qualifications, all work performed by the certified welding inspector, all appropriate nondestructive testing of welds and all repair and retest of weld defects.
7. Testing, including sampling, shall be performed by the Contractor's testing firm's laboratory personnel, in the manner and frequency indicated in the Specifications. The Engineer shall have the right to stipulate the location of the confirmation tests. The Contractor shall provide preliminary representative samples of materials to be tested, to the testing firm's laboratory, in required quantities.
8. The testing firm's laboratory shall perform all laboratory tests within a reasonable time consistent with the specified standards and will furnish a written report of each test.
9. Where such inspection and testing are to be conducted by an independent laboratory agency, the sample or samples shall be selected by such laboratory or agency or the Engineer and shipped to the laboratory by the Contractor at Contractor's expense.
10. Notify laboratory sufficiently in advance of operation to allow for the assignment of personnel and schedules of tests.

F. Transmittal of Test Reports:

1. Written reports of tests and engineering data furnished by Contractor for Engineer's review of materials and equipment proposed to be used in the Work shall be submitted as specified for Shop Drawings. Final transmittal of all Project testing records will be required as a final close-out submittal for the release of retainage.
2. Promptly process and distribute all required copies of test reports and related instructions to insure all necessary retesting or replacement of materials with the least possible delay in progress of the Work.

**+++ END OF SECTION 01400 +++**

---

**SECTION 01410**

**Testing Laboratory Services**

**PART 1 – GENERAL**

**1.01 GENERAL**

- A. This Section includes testing which the City requires to determine if materials or construction methods provided for the Project meet the requirements of these Specifications.
- B. This work does not include manufacturer testing to demonstrate product compliance with various sections of these Specifications, e.g., testing of pipe material properties. This work also does not include testing of system component functionality, e.g. installed pipes, pump systems, manholes, etc.
- C. The testing laboratory or laboratories will be selected by the City. The testing laboratory or laboratories will work for the City and will be paid by the City through the project Owner Allowance fund.

**1.02 PAYMENT FOR TESTING SERVICES**

- A. The testing schedule shall be set and coordinated by the Contractor.
- B. The cost of additional material testing services not specifically required in the Specifications, but requested by the City or Engineer, shall be paid for by the City. The Contractor shall accommodate such additional testing and coordinate with the schedule.
- C. The cost of product type testing described in various sections of these Specifications or as required in referenced standards to be provided by a product manufacturer, shall be included in the price bid for that item, and shall not be paid for by the City.
- D. The cost of component functionality testing described in various sections of these Specifications shall be included in the price bid for that item when indicated in Section 01200, e.g., cured-in-place pipe liner sampling and testing, manhole vacuum testing, pipe infiltration/exfiltration testing, etc.
- E. The Contractor will add all testing activities to the project schedule at the beginning of the work. The cost of retesting any item that fails to meet the requirements of these Specifications and/or false starts due to the Contractor's failure to properly schedule testing technicians in accordance with scheduled work shall be paid for by the Contractor. Retesting shall be performed by the testing laboratory working for the City.

### 1.03 LABORATORY DUTIES

- A. Cooperate with the City, Engineer and Contractor.
- B. Provide qualified personnel promptly on notice.
- C. Perform specified inspections, sampling and testing of materials.
  - 1. Comply with specified standards, ASTM, other recognized authorities, and as specified.
  - 2. Ascertain compliance with requirements of the Contract Documents.
- D. Promptly notify the Engineer and Contractor of irregularity and/or deficiency of work observed during performance of services.
- E. Promptly submit three copies (two copies to the Engineer and one copy to the Contractor) of report of inspections and tests in addition to those additional copies required by the Contractor, with the following information included:
  - 1. Date issued
  - 2. Project title and number
  - 3. Testing laboratory name and address
  - 4. Name and signature of inspector
  - 5. Date of inspection or sampling
  - 6. Record of temperature and weather
  - 7. Date of test
  - 8. Identification of product and Specification section
  - 9. Location of Project
  - 10. Type of inspection or test
  - 11. Results of test
  - 12. Observations regarding compliance with the Contract Documents
- F. Perform additional services as required.



- G. The laboratory is not authorized to release, revoke, alter or enlarge on requirements of the Contract Documents, or approve or accept any portion of the Work.

#### **1.04 CONTRACTOR RESPONSIBILITIES**

- A. Cooperate with laboratory personnel, and provide access to Work and/or manufacturer's requirements.
- B. Provide to the laboratory, representative samples, in required quantities, of materials to be tested.
- C. Furnish required labor and facilities to:
  - 1. Provide access to Work to be tested
  - 2. Obtain and handle samples at the site
  - 3. Facilitate inspections and tests
  - 4. Furnish and maintain a holding box for concrete cylinders and/ or other samples as required by the laboratory
- D. Notify the laboratory sufficiently in advance of operation to allow for the assignment of personnel and schedules of tests.
- E. Remit payment to the testing laboratory or laboratories when paid or otherwise paid from the Owner Allowance.
- F. Laboratory Tests: Where such inspection and testing are to be conducted by an independent laboratory agency, the sample(s) shall be selected by such laboratory or agency, or the Engineer, and shipped to the laboratory by the Contractor at Contractor's expense.
- G. Copies of all correspondence between the Contractor and testing agencies shall be provided to the Engineer.

#### **1.05 QUALITY ASSURANCE**

- A. Testing shall be in accordance with all pertinent codes and regulations and with procedures and requirements of the American Society for Testing and Materials (ASTM).

## **1.06 PRODUCT HANDLING**

- A. Promptly process and distribute all required copies of test reports and related instructions to insure all necessary re-testing or replacement of materials with the least possible delay in the progress of the Work.

## **1.07 FURNISHING MATERIALS**

- A. The Contractor shall be responsible for furnishing all materials necessary for testing.

## **1.08 CODE COMPLIANCE TESTING**

- A. Inspections and tests required by codes or ordinances or by a plan approval authority, and made by a legally constituted authority, shall be the responsibility of, and shall be paid for by the Contractor, unless otherwise provided in the Contract Documents.

## **1.09 CONTRACTOR'S CONVENIENCE TESTING**

- A. Inspection or testing performed exclusively for the Contractor's convenience shall be the sole responsibility of the Contractor.

## **1.10 SCHEDULES FOR TESTING**

- A. Establishing Schedule:
  - 1. The Contractor shall, by advance discussion with the testing laboratory selected by the City, determine the time required for the laboratory to perform its tests and to issue each of its findings, and make all arrangements for the testing laboratory to be on site to provide the required testing.
  - 2. Provide all required time within the construction schedule.
- B. When changes of construction schedule are necessary during construction, coordinate all such changes of schedule with the testing laboratory as required.
- C. When the testing laboratory is ready to test according to the determined schedule, but is prevented from testing or taking specimens due to incompleteness of the Work, all extra costs for testing attributable to the delay will be back-charged to the Contractor and shall not be borne by the City.

**1.11 TAKING SPECIMENS**

- A. Unless otherwise provided in the Contract Documents, all specimens and samples for tests will be taken by the testing laboratory or the Engineer.

**1.12 TRANSPORTING SAMPLES**

- A. The Contractor shall be responsible for transporting all samples, except those taken by testing laboratory personnel, to the testing laboratory.

END OF SECTION

(This page is intentionally blank)

---

**SECTION 01500****Temporary Control of Construction Operations****PART 1 – GENERAL****1.01 SCOPE**

- A. The work covered by this Section includes furnishing all labor, equipment, and materials required for temporary control of construction operations.

**1.02 RELATED SECTIONS**

- A. The Work of the following Sections specifically apply to the Work of this Section. Other Sections of the Specifications, not referenced below, shall also apply to the extent required for proper performance of Work.

1. Section 02112: Route Clearing
2. Section 02125: Erosion and Sediment Controls
3. Section 02140: Dewatering
4. Section 02491: Rehabilitation of Sanitary Sewer Manholes
5. Section 02575: Removing and Replacing Pavement
6. Section 02730: Sewers and Accessories
7. Section 02750: Wastewater Flow Control

**1.03 PUMPING**

- A. The Contractor shall furnish and operate pumping and appurtenant piping for dewatering, flow rerouting, or any similar purposes.
- B. Standard Pumping equipment (as opposed to Reduced Noise Emitting Pumps ex. Quiet Zone, etc.) that could disturb the public shall be operated only during a standard workday or as approved in writing by the Engineer.
- C. No discharge of raw sewage will be permitted to area watercourses under any circumstances. The Contractor shall be held responsible for any such discharge including, but not limited to, fines, legal fees, and any other cost associated with such a discharge.

#### **1.04 TEMPORARY FACILITIES**

- A. The Contractor shall provide all temporary facilities for water, heat, electric light, and power as required for the work during the entire period of operations. Contractor shall be responsible for payment of utility costs for the duration of construction.
- B. The Contractor shall provide temporary toilets as required and shall maintain them in a sanitary condition for the duration of the work and remove them at completion.
- C. On or before the completion of the work, the Contractor shall remove all temporary facilities, together with all rubbish and trash, as directed by the Engineer.

#### **1.05 STORAGE**

- A. The Contractor shall secure adequate storage to accommodate the required equipment, vehicles, and materials for the period of performance of the Contract.

#### **1.06 USE OF PREMISES**

- A. The Contractor shall not load nor permit any part of any structures to be loaded with a weight that will endanger its safety.
- B. The Contractor shall confine his apparatus, the storage of materials and the operations of his workers to the limits defined by laws, ordinances, permits, or directions of the Engineer and shall not unduly encumber the premises with his materials.
- C. The Contractor shall enforce the instructions of the Engineer regarding signs, advertisements, fire and smoking.

#### **1.07 FLOW CONTROLS**

- A. During the entire span of the construction, including inspection, the Contractor shall be responsible to maintain flow in the sewerage system and service to all properties.
- B. Any line plugging or flow restriction shall be with equipment designed specifically for such purpose. A sewer line plug shall be inserted into the line at a manhole upstream from the section being worked on.
- C. Care shall be taken to prevent sewage from backing into buildings, ponding, flooding, or otherwise damaging public or private property.

- D. Controls shall be utilized to prevent sewage from entering surface drainage facilities or water courses, either directly or as a result of overflow from drainage structures.
- E. When bypass pumping is required and ordered by the Engineer, the Contractor shall supply the necessary pumps, conduits, and other equipment to divert the flow of sewage around the manhole section in which work is to be performed into a downstream section. The bypass system shall be of sufficient capacity to handle all existing flows.
- F. No flows shall be diverted from the sewerage system unless a schedule has been approved by the Georgia Environmental Protection Division.
- G. See Specification Section 02750 – Wastewater Flow Control, for additional requirements.

#### **1.08 MAINTENANCE OF EXISTING OPERATION**

- A. The Contractor shall schedule all demolition and construction and maintain continuous operation of the existing wastewater system facilities.
- B. Piping to be abandoned shall be plugged with concrete in a manner approved by the Engineer, so as to be made watertight. All active utilities traversing the site shall be preserved in operating condition.

#### **1.09 MAINTENANCE DURING CONSTRUCTION**

- A. The Contractor shall maintain, at his expense, the work during construction and until final acceptance of all work under the Contract. Continuous and effective work shall be prosecuted day by day, with adequate equipment and forces as required to keep the backfill, pavement, structures, pipe lines and other features in satisfactory and acceptable condition at all times.
- B. In the event the Contractor fails to remedy any unsatisfactory situation, within twenty-four hours after receipt of written notice from the Engineer describing the unsatisfactory conditions, the City may immediately proceed with adequate forces and equipment to maintain the project; and the entire cost of this maintenance will be deducted from the monies otherwise due the Contractor under the Contract.
- C. As an alternative to the above specified maintenance, the cost of all of the items, which are not properly maintained, may be deducted at the Contract Prices from the current partial payment request even if such items have been paid for in previous estimates.

## 1.10 CLEAN-UP AND DISPOSAL

- A. At the end of each day's operation, the Contractor shall thoroughly clear the work site of all dirt or debris, and generally restore the site to an acceptable condition. Upon completion of the work, all excess material and rubbish shall be removed from the job site and disposed of. The surrounding construction area shall be left in as good a condition as that which existed prior to construction.
- B. The Contractor shall transport and expeditiously dispose of all materials removed from the construction site. Disposal shall be at a site approved by the Engineer at no additional cost to the City and in a manner consistent with all-applicable codes and regulations.

## 1.11 CONSTRUCTION ALONG HIGHWAYS, STREETS, AND ROADWAYS

- A. Install pipe lines and appurtenances along highways, streets and roadways in accordance with the applicable regulations of, and permits issued by, the Georgia Department of Transportation and City of Atlanta, with reference to construction operations, safety, traffic control, road maintenance and repair.
- B. Traffic Controls:
  - 1. The Contractor shall provide, erect, and maintain all necessary barricades; suitable and sufficient lights and other traffic control devices; provide qualified flagmen where necessary to direct traffic; take all necessary precautions for the protection of the work and the safety of the public. Flagmen shall be certified by a Georgia DOT-approved flagman training program.
  - 2. Construction traffic control devices and their installation shall be in accordance with the current Manual on Uniform Traffic Control Devices for Streets and Highways.
  - 3. Placement and removal of construction traffic control devices shall be coordinated with the Georgia Department of Transportation and City a minimum of 48 hours in advance of the activity.
  - 4. Placement of construction traffic control devices shall be scheduled ahead of associated construction activities. Construction time in street right-of-way shall be conducted to minimize the length of time traffic is disrupted. Construction traffic control devices shall be removed immediately following their useful purpose. Traffic control devices used intermittently, such as "Flagmen Ahead," shall be removed and replaced when needed.



5. Existing traffic control devices within the construction work zone shall be protected from damage. Traffic control devices requiring temporary relocation shall be located as near as possible to their original vertical and horizontal locations. Original locations shall be measured from reference points and recorded in a log prior to relocation. Temporary locations shall provide the same visibility to affected traffic as the original location. Relocated traffic control devices shall be reinstalled in their original locations as soon as practical following construction.
6. Construction traffic control devices shall be maintained in good repair, and shall be clean and visible to affected traffic for daytime and nighttime operation. Traffic control devices affected by the construction work zone shall be inspected daily.
7. Construction warning signs shall be black legend on an orange background. Regulatory signs shall be black legend on a white background. Construction sign panels shall meet the minimum reflective requirements of the Georgia Department of Transportation and City of Atlanta. Sign panels shall be of durable materials capable of maintaining their color, reflective character and legibility during the period of construction.
8. Channelization devices shall be positioned preceding an obstruction at a taper length as required by the current Manual on Uniform Traffic Control Devices for Streets and Highways, as appropriate for the speed limit at that location. Channelization devices shall be patrolled to insure that they are maintained in the proper position throughout their period of use.

C. Construction Operations:

1. Perform all work along highways, streets and roadways to minimize interference with traffic.
2. Stripping: Where the pipe line is laid along road right-of-way, strip and stockpile all sod, topsoil and other material suitable for right-of-way restoration.
3. Trenching, Laying and Backfilling: Do not open the trench any further ahead of pipe laying operations than is necessary. Backfill and remove excess material immediately behind laying operations. Complete excavation and backfill for any portion of the trench in the same day.
4. Shaping: Reshape damaged slopes, side ditches, and ditch lines immediately after completing backfilling operations. Replace topsoil, sod and any other materials removed from shoulders.

5. Construction operations shall include cleanup and utility exploration.
- D. Excavated Materials: Do not place excavated material along highways, streets and roadways in a manner that obstructs traffic. Sweep all scattered excavated material off the pavement in a timely manner.
- E. Drainage Structures: Keep all side ditches, culverts, cross drains, and other drainage structures clear of excavated material. Care shall be taken to provide positive drainage to avoid ponding or concentration of runoff.
- F. Landscaping Features: Landscaping features shall include, but are not necessarily limited to, fences, property corners, cultivated trees, and shrubbery, man-made improvements, subdivision signs, and other signs within the right-of-way and easement. The Contractor shall take extreme care in moving landscape features and promptly re-establishing these features.
- G. Maintaining Highways, Streets, Roadways and Driveways:
1. Maintain streets, highways, roadways and driveways in suitable condition for movement of traffic until completion and final acceptance of the work.
  2. During the time period between pavement removal and completing permanent pavement replacement, maintain highways, streets, and roadways by the use of steel running plates. The edges of running plates shall have asphalt placed around their periphery to minimize vehicular impact. The backfill above the pipe shall be compacted, as specified elsewhere up to the existing pavement surface to provide support for the steel running plates.
  3. Furnish a road grader or front-end loader for maintaining highways, streets, and roadways. Make the grader or front-end loader available at all times.
  4. Immediately repair all driveways that are cut or damaged. Maintain them in a suitable condition for use until completion and final acceptance of the work.

## 1.12 ACCESS ROADS

- A. Streets, road and drives used by the Contractor for access to and from the site of the work shall be protected from damage caused by the normal traffic of vehicles used for or in connection with construction work. Any such damage done shall be repaired immediately and left in good condition at the end of the construction period. Any new access road construction shall be “all weather” and have drainage structures placed as shown or as required.

END OF SECTION

(This page is intentionally blank)

---

**SECTION 01540**

**Security and Safety**

**PART 1 – GENERAL**

**1.01 COMPLIANCE WITH CITY’S SECURITY REQUIREMENTS**

- A. Contractor must comply with City’s security requirements for all job sites and Department of Watershed Management (DWM) facilities. The City shall provide copies to the Contractor.
- B. Contractor must cooperate with City on all security matters and must promptly comply with any project security arrangements established by the City.
- C. It is the Contractor’s obligations to comply with all applicable governmental requirements and regulations and to undertake reasonable actions to establish and maintain secure conditions at any jobsite.

**1.02 SECURITY PROGRAM**

- A. The Contractor shall comply with the site security program at all times on City facilities.
- B. The Contractor shall maintain the security program throughout the Contract duration.
- C. The Contractor and his subcontractors are wholly responsible for the security of their employees, work areas, and for all their material, equipment and tools at all times.
- D. The Contractor shall provide the City with a list of 24-hour emergency phone numbers including chain of command.

**1.03 ENTRY CONTROL**

- A. The Contractor shall restrict entry of unauthorized personnel and employees and vehicles onto the Project site.
- B. The Contractor shall allow entry only to authorized persons with proper City-approved identification.
  - 1. All Contractors/Subcontractors will be required to have their personnel working at these facilities photographed for an identification (I.D.) badge before they start work.

- C. The Contractor shall maintain a current Employee Log of employees performing work on site, as well as a Visitor Log, and make the log available to the City upon request. This log shall be available to the City upon request and submitted to the City as necessary.
- D. The Contractor shall require all employees performing activities on site to sign the “Employee Acknowledgment of Project Site Rules Log” included at the end of this Section. All employees, subcontractor employees and lower tier contractor employees will attend a new employee orientation session. Signature of the Employee Log by the employee certifies that the orientation training has been received.
- E. The City has the right to refuse access to the site or request that a person or vehicle be removed from the site if found violating any of the safety, security, or conduct rules as outlined.

#### **1.04 BARRICADES, LIGHTS AND SIGNALS**

- A. The Contractor shall furnish and erect such barricades, fences, lights, danger signals and other precautionary measures for the protection of persons or property and of the work as necessary.
- B. The Contractor will be held responsible for all damage to the work and any negligence resulting in injuries due to his failure of erecting adequate barricades, signs, lights and safety provisions as required. Whenever evidence is found of such damage, the Contractor shall immediately remove the damaged portion and replace it at the Contractor's cost and expense.
- C. The Contractor's responsibility for the maintenance of barricades, signs and lights shall not cease until the City has been accepted in writing the Project.

#### **1.05 RESTRICTIONS**

- A. The Contractor shall not allow cameras on site or photographs to be taken, except those that are required to perform the Work in accordance with the Contract Documents or otherwise approved by the City.

#### **1.06 CONTRACTOR SAFETY/HEALTH AND SECURITY PLAN**

- A. Prior to the performance of any work, the Contractor will prepare and submit a Safety/Health and Security Plan which includes the following minimum requirements:

1. Basic pre-employment background checks for criminal convictions, veracity of previous employment and education statements, driving record and financial responsibility as applicable to the position.
2. Security Education and Awareness training applicable to the job.
3. Standard operating procedures (SOPs) for safeguarding City equipment, supplies and property.
4. Certification requested under the SAFETY Act, Homeland Security Act of 2002, if applicable. Provide date and result as requested.
5. Established process for identification of employees and emergency notification procedures.
6. If applicable, procedures for entry permits and badges. Procedures for returning badges upon termination of employment.
7. Anti-terrorism training provided to employees including the state of national alert with appropriate procedures.
8. Emergency evacuation procedures including accounting for employees at a safe haven.
9. Procedures for reporting post-contract criminal convictions and traffic accidents to the Contract Officer or DWM project manager.
10. SOPs for protecting employees when performing required duties off-site including training for reporting accidents, calling for immediate assistance, job reporting procedures and personal duress codes or alarms.
11. Contact information for the person(s) responsible for implementation and enforcement of Safety/Health and Security rules and regulations for this contract.
12. Safe work procedures for the activities within the Contractor's scope of work.
13. New employee orientation program, which addresses job and site specific rules, regulations and hazards.
14. The Contractor's Drug Free Work Place Policy including substance abuse prevention and testing program.
15. Provisions to protect all of the Contractor's employees, other persons and organizations that may be affected by the work from injury, damage or loss.

16. Demonstration of compliance with current Fed/OSHA, Safety/Health and Security Plan, facility safety program (when applicable), and locally accepted safety codes, regulations and practices.
  17. A site-specific emergency action and evacuation plan.
  18. Hazard Communication/Right To Know Program.
  19. Security procedures for the Contractor's work, tools, and equipment.
  20. Capability of providing the Engineer with documentation to show compliance with their plan, plus accidents and investigation reports.
  21. Any other contract specific requirements.
- B. It is not the City's responsibility to verify the Contractor's safety plan for the adequacy and compliance of the plan.
  - C. Provide a Job Safety Analysis (JSA) for the scope of work, prior to the start of work.
  - D. Review of the Contractor's Safety Plan by the City shall not impose any duty or responsibility upon the City for the Contractor's performance of the work in a safe manner.
  - E. The Contractor shall be fully responsible for the safety and health of its employees, its subcontractors and lower tier contractors during performance of its work.
  - F. The Contractor shall provide the City with all safety reports, training records, competent person list, and accident reports prepared in compliance with Fed/OSHA and the Project Safety/Health and Security Plan as requested.

#### **1.07 PROJECT SAFETY COORDINATOR**

- A. The Contractor shall be responsible for the safety of the Contractor's and Engineer's employees, the City's personnel and all other personnel at the site of the work caused by their operations.
- B. The Contractor shall have a Project Safety Coordinator, as required by Section GC-18 of the General Conditions.



- C. The Project Safety Coordinator shall ensure compliance with all applicable health and safety requirements of all governing legislation.

#### **1.08 PROJECT SAFETY/SECURITY REQUIREMENTS OF THE CONTRACTOR**

- A. It is the responsibility of the Contractor to ensure that all articles of possible personal or monetary value found by Contractor's employees are turned in to the appropriate City Project Manager.
- B. The Contractor shall be responsible for maintaining satisfactory standards of employees' competency, conduct, courtesy, appearance, honesty, and integrity, and shall be responsible for taking such disciplinary action with respect to any employee, as may be necessary.
- C. Should the Contractor dismiss employees who have been given access to DWM facilities while the contract is in force, the Contractor will advise the DWM Security office.
- D. The City may request the Contractor to immediately remove from the premises and/or dismiss any employee found unfit to perform duties due to one or more of the following reasons:
  - 1. Neglect of duty, absenteeism, security or safety problems and sleeping on the job.
  - 2. Disorderly conduct, use of abusive or offensive language, quarreling, intimidation by words or actions or fighting.
  - 3. Theft, vandalism, immoral conduct of any other criminal action.
  - 4. Selling, consuming, possessing, or being under the influence of intoxicants, alcohol, or illegal substances, which produce similar effects while on duty.
  - 5. Vehicle accident while on City property or driving City equipment. No employee, Contractor, or Subcontractor will be extended privileges to drive City equipment on City property if driving privileges have been withdrawn by the State of residence.
- E. All employees shall be required to sign in and out on a designated log sheet.
- F. All employees shall be required to wear at all times in an observable location, above the waist, on outer clothing, appropriate photo I. D. badges to be furnished by the Contractor and approved by the City.

- G. No one under age sixteen is permitted at work sites after normal working hours. Contractor's employees are allowed on work sites only during the specified hours and only when working on this contract. No Contractor employee will be allowed on work sites when not specifically working on this Contract Ft predetermined times and dates.

#### **1.09 EMPLOYEE ACKNOWLEDGEMENT OF THE PROJECT SITE RULES**

- A. All employees and agents of the Contractor must read and sign a form to acknowledge understanding of project site rules. A sample log is attached to this Section.
- B. By Signing this Employee Log, I acknowledge that I understand and agree to abide by the project rules outlined below. I further acknowledge that I have been briefed on specific hazards, hazardous substances that are on-site and the site emergency action procedure.
- C. PROHIBITED ACTIVITIES:
1. Unauthorized removal or theft of CITY property
  2. Violation of safety or security rules or procedures
  3. Possession of firearms or lethal weapons on jobsite
  4. Acts of sabotage
  5. Destruction or defacing CITY property
  6. Failure to use sanitary facilities
  7. Failure to report accidents or job related injuries
  8. Being under the apparent influence of drugs, alcohol or other intoxicants or in possession of drugs, alcohol or other intoxicants on the property
  9. Wearing shorts or tennis shoes on the jobsite
  10. Failure to wear a hardhat/safety glasses as required by law.
  11. Gambling at any time on the project
  12. Fighting, threatening behavior, or engaging in horseplay on the project
  13. Smoking in unauthorized areas on the project
  14. Open fire cooking or making unauthorized fires on project property
  15. Selling items or raffles without authorization
  16. Use of unauthorized cameras on the project
  17. Use of radio or television in the construction area
  18. Failure to park personal vehicle in authorized parking area
  19. Failure to wear designated identification [Site Specific]
  20. Failure to use designated gates
  21. Use or storage of unauthorized chemicals or substances on site.
- D. I have read, understand and agree to abide by the PROJECT SITE RULES. Furthermore, I understand failure to abide by these rules is

grounds for being denied access to the project site. I have received a personal copy for my use and reference.

#### **1.10 OFFICE, MATERIAL AND EQUIPMENT SECURITY**

- A. The Contractor is solely responsible for the security of any offices or any temporary staging areas utilized by the Contractor. The Contractor is also responsible for the security of his materials, tools, vehicles and equipment on-site at all of the various work locations throughout the City.

EMPLOYEE LOG

BY SIGNING THIS LOG I ACKNOWLEDGE THAT I HAVE READ, UNDERSTAND AND AGREE TO ABIDE BY THE PROJECT RULES OUTLINED ABOVE AND ALL LOCAL, STATE, FEDERAL, AND/OR ANY OTHER CONTRACT OBLIGATIONS THAT MAY APPLY. I FURTHER ACKNOWLEDGE THAT I HAVE BEEN ORIENTATED BY A REPRESENTATIVE OF THE COMPANY AS TO THE SITE SPECIFIC HAZARDS, ANY HAZARDOUS SUBSTANCES THAT I MAY BE EXPOSED TO WHILE ON THE SITE AND THE SITE/COMPANY EMERGENCY ACTION PROCEDURES.

EMPLOYEES (PRINT)	SIGNATURE	COMPANY NAME	DATE
Signature of Company Representative		Date Signed	



(This page is intentionally blank)

---

**SECTION 01580**

**Project Identification and Signs**

**PART 1 – GENERAL**

**1.01 SCOPE**

- A. The work under this Section requires the Contractor to furnish, utilize and maintain project signage and custom vinyl magnetic vehicle signs throughout the duration of the project.

**1.02 DESIGN**

- A. The Contractor shall submit to the Engineer for approval a scale drawing showing the graphic design, style of lettering, and colors, configured to match the design issued by the City Public Involvement (PI) Office. The PMT and/or PI Office will provide the art ready templates for all CWA signage at the Public Information Kick-off Meeting described in Section 01351.

**PART 2 – PRODUCTS**

**2.01 MATERIALS**

- A. Project Signs
  - 1. All building and graphic materials shall be exterior grade and suitable for environmental exposure without any visible fading, warping or delaminating.
  - 2. All lumber shall be pressure treated number 2 grade with a minimum of 0.25 pounds per cubic foot wood preservative.
  - 3. All fasteners shall be hot dip galvanized.
  - 4. Each project sign shall be painted white with color sign graphic as indicated on Attachment 1.
  - 5. The minimum sign size shall be 96 inches wide by 48 inches high.
- B. Magnetic Vehicle Signs
  - 1. Each sign shall be durable nylon having a 100% magnetic surface with strong magnetic cling.

2. The minimum sign size shall be 24 inches wide by 12 inches high.
3. The magnetic sign graphic shall have a professional appearance with fade resistant color printed layout.

C. Yard Signs

1. Yard signboards shall be made of corrugated plastic panel suitable for exterior use with color graphic print on both sides.
2. Each signboard shall be securely attached to a single metal wire stand frame. The wire frame shall be zinc coated or galvanized surface to resist corrosion.
3. The minimum sign size shall be 36 inches wide by 24 inches high.

## **PART 3 – EXECUTION**

### **3.01 GENERAL**

A. Project Signs

1. The Contractor shall construct each project signboard to accommodate the minimum dimensions per Attachment 1 herein.
2. Each sign shall have a minimum of two end post securely anchored to a minimum depth of 2 feet below grade. Each post shall be sufficient length to provide a finished bottom edge signboard elevation 4 feet above grade without splices or other wood joints unless otherwise directed by the City.
3. All fasteners shall be flush with surface with smooth wood edges in a constructed in a neat manner free of irregular cuts, tear out or other undesirable visible defects.
4. The project sign shall be located at the project entrance as directed by the City Public Information officer.

B. Magnetic Vehicle Signs

1. Contractor shall utilize the magnetic signs for all vehicles performing work under this Contract while the vehicles are on the site or otherwise engaged in the Contract Work.
2. Contractor shall place the magnetic signs on each vehicle in a high visibility location. If the signs are to be placed on the sides of



vehicles, two signs shall be utilized per vehicle (one sign per side). If the signs are to be placed on the rears of vehicles, one sign per vehicle shall be acceptable.

3. Contractor shall replace the signs during the project as necessary or as directed by the Engineer.

B. Yard Signs

1. Contractor shall install and maintain yard signs as directed by the City Public Information Officer (PIO).

**3.02 MAINTENANCE**

- A. Contractor shall periodically inspect and maintain all signage in good condition throughout the Contract period at no additional cost to the City.

END OF SECTION

---

**SECTION 01590**

**Field Offices**

**PART 1 - GENERAL**

**1.01 SCOPE**

- A. The Contractor shall provide all temporary facilities and necessary staff personnel for the proper completion of the Work as specified.
- B. Maintain temporary facilities in proper and safe condition through the progress of the Work. In the event of loss or damage, immediately make all repairs and replacements necessary subject to approval of the Engineer and at no additional cost to City. At completion of the Work remove all such temporary facilities or as directed by the Engineer.

**1.02 REQUIREMENTS**

- A. General
  - 1. The materials, equipment, and furnishings provided under this Section shall be new, and shall meet all the applicable codes and regulations.
  - 2. Make all provisions, and pay all costs of furnishing, installation, maintenance, professional services, permit fees, property leases, and site work including all utilities for the temporary facilities.
- B. Field Personnel
  - 1. The Contractor's administrative field office shall be maintained at a staffing level sufficient to plan, coordinate and have authority to promptly execute the Work on site with the corresponding City personnel. At a minimum, the Contractor's project manager, public information officer, safety officer, superintendent and one administrative support person shall occupy and be available at the field office each workday.
- C. Field Office Construction
  - 1. Temporary mobile/modular field office buildings shall be structurally sound, weather tight, with floors raised above ground. Mobile/modular buildings shall comply with GA-DCA/SBCC/ADA requirements, and shall be G E – Modular Space, Williams-Scottsman or equal.

2. Temporary field office buildings shall have temperature transmission resistance compatible with occupancy and storage requirements. The office buildings shall be properly skirted as approved by the Engineer.

### **1.03 CONTRACTOR'S FACILITIES**

- A. Contractor shall submit a plan of the temporary field office building layout to Engineer for approval within 15 days of the Notice to Proceed. Contractor's facilities, for purposes of this Section, is defined to include but is not limited to its administrative field office located within a five (5) mile radius of the project site. The field office shall have a first aid station and be centrally located to the Work. The Contractor's operational field office shall have a storage facility (for both materials and equipment). Insufficient, inadequate, improper facilities or equipment shall be brought to acceptable condition or shall be removed from either site.
- B. The Contractor's administrative field office shall include a dedicated meeting/conference room for hosting bi-weekly progress or other meetings with City and Engineer representatives. Size the room to comfortably seat a minimum of ten (10) people. Proper ventilation, temperature control and lighting are required, and shall be provided to the satisfaction of the Engineer.
- C. The location of stationary and mobile equipment shall be subject to the Engineer's approval.
- D. First Aid Station: Contractor shall provide a suitable first aid station at the administrative field office and the Contractor's operational field office. Each station shall be equipped with all facilities and medical supplies necessary to administer emergency first aid treatment. Contractor shall have standing arrangements for the removal and hospital treatment of any injured person. The information reflecting this arrangement shall be clearly posted for easy visibility. All first aid supplies and emergency ambulance service shall be made available by the Contractor to the Contractor's, City's and Engineer's personnel.

### **1.04 ENGINEER'S FACILITIES (Not Used)**

### **1.05 COMMUNICATIONS SERVICES**

- A. General
  1. Make all necessary arrangements for outside telephone and internet access service to Contractor's administrative field office and Contractor's operational field office. All portions of the communication system shall be maintained in good working

condition.

2. At a minimum, furnish two telephone lines to the Contractor's administrative field office and Contractor's operational field office. One will be used for a dedicated facsimile machine.
3. All expenditures for installation costs of hardware, lines, line extensions, service charges, and recurring service charges for telephone and internet access service shall be included in the unit price for the Contractor's temporary facilities item.

## **1.06 PARKING FACILITIES**

### **A. General**

1. Provide parking, either graveled or paved, adjacent to Contractor's administrative field office and Contractor's operational field office, without necessitating jockeying of cars, for a minimum of 2 cars for the use of City's or Engineer's personnel when visiting the Contractor's administrative field office or Contractor's operational field office. The parking surfaces shall be promptly and adequately maintained by the Contractor for the duration of the Contract.
2. Additional parking facilities required by the Contractor shall be the Contractor's responsibility.

## **1.07 FACILITIES FOR PROJECT CONTROL TOOLS**

- A. The Contractor shall have adequate computer system capability in its administrative field office and Contractor's operational field office facilities to connect to and use the City's Project Control Tools (refer to Section 01350). The connection method shall be based upon the physical connections availability at the various field and office locations. The priority preference for these connections is: DSL, Cable Modems, and if necessary T1 connections. No dial-up modems will be allowed. The monthly charges for these services shall be paid by the Contractor for the duration of the contract. Costs shall be included in the unit price item for the Contractor's temporary facilities.
- B. The Contractor's connection computer(s) must have a minimum operating system of Windows 2000 or greater, 1.8 Hz speed with 256mb RAM. The Internet Explorer web browser must be version 5.5 or greater. The Contractor's printers must not be USB connection printers. The printer(s) must be a dedicated printer, HP LaserJet compatible.

- C. No partial payment for the Contractor's temporary facilities unit price item will be approved until all connections are provided and installed to the satisfaction of the City's Project Controls Support Group.

## **1.08 SECURITY AND MAINTENANCE**

### **A. General**

1. Provide periodic indoor and outdoor maintenance and cleaning for temporary structures, furnishings, equipment and services as specified herein above.
2. Provide racks and files for Project Record Documents to be turned over to the City at the completion of the project.

## **PART 2 - PRODUCTS (NOT USED)**

## **PART 3 - EXECUTION**

### **3.01 PREPARATION**

- A. Fill and grade sites for temporary structures to provide surface drainage.

### **3.02 INSTALLATION**

- A. Construct temporary administrative field office, Contractor's operational field office, first aid station, and storage facilities on proper foundations and complete connections for utility all services.
- B. Locate temporary administrative field office facilities at an Area Compound location provided by the City and locate Contractor's operational field office within a five (5) mile radius of the administrative field office Area Compound, as approved by the Engineer.
- C. Determine the need for temporary utility services, including utility services for Contractor's administrative field office, Contractor's operational field office and first aid station, and make all arrangements with utility companies and governmental agencies to secure such services. Temporary utility services shall be furnished, installed, connected, and maintained by Contractor in a workmanlike manner, and shall be removed in like manner prior to final project acceptance.

### **3.03 MAINTENANCE AND CLEANING**

- A. At a minimum, repair and clean the offices, parking areas and access routes and provide complete professional janitorial services, including toilet paper and paper towels, in the Contractor's administrative field office

and Contractor's operational field office. Contractor's administrative field office and Contractor's operational field office cleaning shall be done to the satisfaction of the Engineer. These services shall include sweeping, vacuuming, dusting, emptying of trash, cleaning of washbasins, bathroom and shower facilities, mopping and waxing of all floors. Contractor shall also provide for exterminating services of the offices if requested by the Engineer.

### **3.04 REMOVAL**

- A. Remove or discontinue temporary field offices, contents and services at a time when no longer needed.

END OF SECTION

---

**SECTION 01610**

**TRANSPORTATION AND HANDLING**

**PART 1 – GENERAL**

**1.01 SCOPE**

- A. The Contractor shall provide transportation of all equipment, materials, and products furnished under these Contract Documents to the Work site. In addition, the Contractor shall provide preparation for shipment, loading, unloading, handling and preparation for installation and all other work and incidental items necessary or convenient to the Contractor for the satisfactory prosecution and completion of the Work.
- B. All equipment, materials, and products damaged during transportation or handling shall be repaired or replaced, prior to being incorporated into the Work, by the Contractor at no additional cost to the City

**1.02 TRANSPORTATION**

- A. All equipment shall be suitably boxed, crated, or otherwise protected during transportation.
- B. Where equipment will be installed using existing cranes or hoisting equipment, the Contractor shall ensure that the weights of the assembled sections do not exceed the capacity of the cranes or hoisting equipment.
- C. Small items and appurtenances such as gauges, valves, switches, instruments, and probes that could be damaged during shipment shall be removed from the equipment prior to shipment, packaged, and shipped separately. All openings shall be plugged or sealed to prevent the entrance of water or dirt.

**1.03 HANDLING**

- A. All equipment, materials, and products shall be carefully handled to prevent damage or excessive deflections during unloading or transportation.
- B. Lifting and handling drawings and instructions furnished by the manufacturer or supplier shall be strictly followed. Eyebolts or lifting lugs furnished on the equipment shall be used in handling the equipment. Shafts and operating mechanisms shall not be used as lifting points. Spreader bars or lifting beams shall be used when the distance between lifting points exceeds that permitted by standard industry practice.

- C. Under no circumstances shall equipment or products such as pipe, structural steel, castings, reinforcement, lumber, piles, poles, etc., be thrown or rolled off of trucks onto the ground.
- D. Slings and chains shall be padded as required to prevent damage to protective coatings and finishes.

END OF SECTION



---

**SECTION 01611**

**Storage and Protection**

**PART 1 – GENERAL**

**1.01 SCOPE**

- A. The work under this Section includes, but is not necessarily limited to, the furnishing of all labor, tools and materials necessary to properly store and protect all materials, equipment, products and the like, as necessary for the proper and complete performance of the Work.
- B. The Contractor shall store materials, supplies, and equipment at the site in such orderly fashion and in such locations as approved by the Engineer that will not unduly interfere with the progress of the Work or the work of any other contractors, or the activities of City personnel.

**1.02 STORAGE AND PROTECTION**

- A. Storage:
  - 1. Maintain ample space for foot traffic at all times, except as otherwise approved by the Engineer.
  - 2. All property damaged by reason of storing of material shall be properly replaced at no additional cost to the City.
  - 3. Packaged materials shall be delivered in original unopened containers and so stored until ready for use.
  - 4. All materials shall meet the requirements of these Specifications at the time that they are used in the Work.
  - 5. Store products in accordance with manufacturer's instructions.
- B. Protection:
  - 1. Use all means necessary to protect the materials, equipment, and products of every section before, during and after installation and to protect the installed work and materials of all other trades.
  - 2. All materials shall be delivered, stored, and handled to prevent the inclusion of foreign materials and damage by water, breakage, vandalism, or other causes.

3. Substantially constructed weathertight storage sheds, with raised floors, shall be provided, and maintained as may be required to adequately protect those materials and products, which may require protection from damage by the elements, stored on the site.
- C. Replacements: In the event of damage, immediately make all repairs and replacements necessary for the approval of the Engineer and at no additional cost to the City.
  - D. Equipment and products stored outdoors shall be supported above the ground on suitable wooden blocks or braces arranged to prevent excessive deflection or bending between supports. Items such as pipe, structural steel and sheet construction products shall be stored with one end elevated to facilitate drainage.
  - E. Unless otherwise permitted in writing by the Engineer, building products, and materials such as cement, grout, plaster, gypsum board, particleboard, resilient flooring, acoustical tile, paneling, finish lumber, insulation, wiring, etc., shall be stored indoors in a dry location. Building products such as rough lumber, plywood, concrete block, and structural tile may be stored outdoors under a properly secured waterproof covering.
  - F. Tarps and other coverings shall be supported above the stored equipment or materials on wooden strips to provide ventilation under the cover and minimize condensation. Tarps and covers shall be arranged to prevent ponding of water.

### **1.03 EXTENDED STORAGE**

- A. In the event that certain items of major equipment such as air compressors, pumps, and mechanical aerators have to be stored for an extended period of time, the Contractor shall provide satisfactory long-term storage facilities that are acceptable to the Engineer. The Contractor shall provide all special packaging, protective coverings, protective coatings, power, nitrogen purge, desiccants, lubricants, and exercising necessary or recommended by the manufacturer to properly maintain and protect the equipment during the period of extended storage.

END OF SECTION

---

**SECTION 01720**

**Record Documents**

**PART 1 – GENERAL**

**1.01 SCOPE**

- A. The work under this Section includes, but is not necessarily limited to, the compiling, maintaining, recording, and submitting of project record documents as herein specified.
  
- B. Record documents include, but are not limited to:
  - 1. Drawings
  - 2. Specifications
  - 3. Change orders and other modifications to the Contract
  - 4. Engineer field orders or written instructions, including Requests for Information (RFI) and Clarification Memorandums
  - 5. Reviewed shop drawings, product data and samples
  - 6. Test records
  - 7. As-built drawings and/or maps, indicating the locations and types of work performed (manhole asset ID numbers clearly shown where appropriate). Position survey coordinates, top of manhole and invert elevations shall be indicated on the drawing for all manholes and/or sewers which are newly constructed, replaced or adjusted to grade. Where service laterals are rehabilitated or replaced (whether partial or complete to property line) indicate approximate location on drawing, as well as method of rehabilitation/repair. As-built pipe diameters and materials shall also be indicated.
  - 8. Map corrections - printed map marked up illustrating the approximate position of any unmapped manholes and sewers discovered (no survey required).
  - 9. Geographic Information System (GIS) data – updated GIS data set indicating the as-built position and attributes for all replaced and rehabilitated sewer mains, manholes and lateral piping.
  
- C. The Contractor shall maintain a current set of Record Drawings and GIS data on the Project site throughout the Contract Time.

## 1.02 MAINTENANCE OF DOCUMENTS AND SAMPLES

- A. Storage:
  - 1. Store documents and samples in the Contractor's field office, apart from documents used for construction
  - 2. Provide files and racks for storage of documents
  - 3. Provide locked cabinet or secure storage space for storage of samples
- B. File documents and samples in accordance with format of these Specifications
- C. Maintenance:
  - 1. Maintain documents in a clean, dry, legible condition and in good order.
  - 2. Do not use record documents for construction purposes.
  - 3. Maintain one copy of all record documents at the site.
- D. Make documents and samples available at all times for inspection by Engineer.
- E. Failure to maintain the Record Documents in a satisfactory manner may be cause for withholding payment.

## 1.03 QUALITY ASSURANCE

- A. Unless noted otherwise, Record Drawings and corresponding GIS data shall provide dimensions, distances, coordinates to the nearest 0.1 foot in North American Datum of 1983 (1986 adjustment) Georgia State Plane West 1002 System format. All coordinate values shall be provided as grid coordinates in US Survey Feet.
- B. Unless noted otherwise, Record Drawings and corresponding GIS data shall provide elevations to the nearest 0.01 foot referenced to the North American Vertical Datum of 1988 (NAVD88) format. All coordinate values shall be provided as grid coordinates in US Survey Feet.
- C. GPS data shall be collected using eGPS Solutions or equivalent internet-based real time GPS network. The network shall provide continuous error

correction and accuracy which meets or exceeds the requirements of Section 1.07 Data Accuracy.

- D. Any transformation or adjustment necessary to reproject surveyed coordinates to the Reference Coordinate System will be the responsibility of the Contractor.
- E. The Contractor shall employ a Professional Land Surveyor (PLS) licensed in the State of Georgia to prepare the Record Drawings from a post-construction, field survey of all manholes or sewers newly constructed, replaced or otherwise adjusted in position or elevation. Additionally, the contractor shall submit the corresponding GIS data accordingly to indicate the as-built condition and GIS data attributes of these structures and pipelines.

#### **1.04 DATA ACCURACY**

- A. High Resolution: For all sanitary sewer structures, the equipment and means used by Contractor must generate the position of points with a minimum accuracy of three (3) centimeters horizontal and three (3) centimeters vertical. To determine the accuracy obtained, Contractor's GPS system will be calibrated daily against a known point (monuments) prior to beginning work and when the work is completed. The Contractor shall submit a report to the Engineer certifying calibration was accomplished and indicating the reference system. Data delivered to the Engineer arising from the GPS survey shall be certified by a Professional Land Surveyor. When the GPS equipment cannot be set directly on the point, conventional surveying methods will be used to establish the position to the stated level of accuracy.
- B. Calibration shall be carried out at least on a daily basis in accordance with the GPS equipment manufacturer's instructions. Additional calibrations may be required during the course of the working day for large fluctuations of temperature and/or humidity, also in accordance with the manufacturer's instructions and tolerances. The Contractor shall submit a report to the Engineer certifying calibration was accomplished and indicating the reference system.

#### **1.05 INTERFERENCE**

- A. A GPS position is required for all newly constructed, replaced or adjusted sanitary point structures regardless of the overhead conditions or other nearby obstructions which may interfere with satellite signals, at no additional cost. In the event coverage conditions do not allow all positions to be obtained by setting directly over the point, rangefinders or other conventional surveying methods may be used to obtain the position of the point(s).

## 1.06 RECORDING

- A. Label each document "PROJECT RECORD" in neat, large printed letters.
- B. Recording:
  - 1. Record information concurrently with construction progress.
  - 2. Do not conceal any work until required information is recorded.

## 1.07 RECORD DRAWINGS

- A. Record Drawings shall be reproducible, shall have a title block indicating that the drawings are Record Drawings, the name of the company preparing the Record Drawings, and the date the Record Drawings were prepared. The Contractor will be provided paper sepias of the Drawings, or it may elect to provide reproducible drawings via another method. Reproducible shall be defined as being translucent so as to allow a blueline print to be produced.
- B. Legibly mark drawings to record actual construction, including:
  - 1. All Construction:
    - a. Changes of dimension, diameter, or material and detail
    - b. Location and type of work performed on each manhole or sewer segment (indicate asset ID numbers)
    - c. Changes made by Requests for Information (RFI), field order, clarification memorandums or by change order
    - d. Details not on original Drawings
    - e. The distance (length) between manhole covers on pipe segments where work was performed.
  - 2. Structures:
    - a. Position coordinates, as well as invert and top elevations of manholes where manholes or sewers have been newly constructed, replaced or adjusted/raised to grade.

**1.08 SPECIFICATIONS**

- A. Legibly mark each section to record:
  - 1. Manufacturer, trade name, catalog number, and supplier of each product and item of equipment actually installed
  - 2. Changes made by Requests for Information (RFI), field order, clarification memorandums, or by change order

**1.09 GIS DATA**

- A. Coordinate and attribute data shall be provided in both electronic and hard copy format at the completion of each sewer-shed, but not less than monthly. The hard copy data must be submitted for approval by the Engineer. Electronic data will not be accepted without hard copy data. Each submittal must be numbered according to the numbering system outlined in Specification Section 01350.
- B. The hard copy data shall include a cover letter and printed spreadsheet that corresponds to the electronic data submitted. If the survey work is performed by a subcontractor, the cover letter shall provide certification of data accuracy by a Professional Land Surveyor (PLS) licensed in the State of Georgia. If the survey work is performed by the prime Contractor, the cover letter shall provide certification of data accuracy by a Professional Land Surveyor (PLS) licensed in any State in the United States of America. The hard copy data must be bound, with the PLS seal placed on the cover letter; OR, the hard copy data may be submitted unbound, with the PLS seal placed on each and every sheet of unbound data submitted.
- C. The attached GPS Certification Form shall be signed and sealed by a Registered Land Surveyor in Georgia and submitted for each sewershed.
- D. The electronic data table submittal shall include four completed worksheets to form a workbook in Microsoft Excel format containing position survey data and physical attributes of the replacement and rehabilitation work. All pipe material, pipe shape and pipe liner code values shall be provided in accordance with in Section 02752 - Attachment C. Numerical value measurement data precision shall be 1/1000 or three decimal places. Each data worksheet shall include individual data records arranged in template formats and header values conforming to examples provided below;

**Manhole Replacement or Rehabilitation Worksheet:**

PointGISID	X_Coord_US	Y_Coord_US	Z_Elev_US	REHAB_METH	Comments	Install Date	Scope Status
------------	------------	------------	-----------	------------	----------	--------------	--------------

23040113201	2204663.500	1349506.320	859.950	Replace MH Frame and Cover	Replaced Vented Cover & Installed Solid Cover	mm/dd/yyyy	Original scope completed as designed

**Pipeline Rehabilitation Worksheet (Use for sewer main open cut replacement, pipe-bursting, push-bursting, horizontal directional drilling or lining):**

PipeGISID	PipeDia	PipeWidth	PipeHeight	PipeGuage	PipeShape	PipeUSDpth	PipeDSDpth
23040113201T23040116501	12.000	0.000	0.000	1.125	C	8.600	15.840

Cont'd

PipeMatl	X_Coord_US	Y_Coord_US	Z_Elev_US	US_Pipe_Elev	X_Coord_DS	Y_Coord_DS	Z_Elev_DS
PE	2204663.500	1349506.320	859.950	851.350	2204313.580	1349469.870	864.350

Cont'd

DS_Pipe_Elev	Length	Slope	REHAB_METH	COMMENTS	Install Date	Scope Status
848.510	351.813	0.008072	PB		mm/dd/yyyy	Original Scope completed as designed

**Point Repair Rehabilitation Worksheet:**

PipeGISID	PipeDia	PipeWidth	PipeHeight	PipeGuage	PipeShape	PipeMatl
-----------	---------	-----------	------------	-----------	-----------	----------



23040113201T23040116501	12.000	0.000	0.000	1.125	C	VC
23040113301T23040113401	0.000	8.000	10.000	0.000	C	CO

Cont'd

REHAB_METH	DISTFRMUSMH	PR_LENGTH	PR_MATERIAL	COMMENTS	Install Date	Scope Status
External	12.700	4.500	VC		mm/dd/yyyy	Rehab scope method revised from original scope
Internal	13.000	6.000	PVC		mm/dd/yyyy	Original scope completed as designed

**Lateral Rehabilitation Worksheet:**

PipeGISID	Addresses	ZIP	Pipe Matl	DIST FRM USMH	Clock Pos	REHAB METH	New CO	Comments	Install Date	Scope Status
23040113201T23040116501	31 Honour Circle, NE	30305	PVC	189.000	9.000	REP	N		mm/dd/yyyy	Work added to original scope
23040113301T23040113401	400 Atlanta Avenue, SW	30309	CPP	13.000	3.000	Lining	Y		mm/dd/yyyy	Original scope completed as designed
13040113901T13044011801	230 Peachtree Street, NE	30303	CPP	89.000	9.000	Top Hat	N		mm/dd/yyyy	Original scope completed as designed

**1.08 SUBMITTAL**

- A. At work assignment or contract closeout (whichever comes first), the Contractor shall submit two copies of Record Documents to the Engineer.

- B. The submittal shall include a transmittal letter, in duplicate, containing:
1. date
  2. project title and number
  3. contractor's name and address
  4. title and number of each record document and
  5. signature of Contractor or Contractor's authorized representative.
- C. Additionally, the Contractor shall edit the digital PDF(s) files furnished for each sewershed to include all changes based upon actual field conditions. The Contractor shall submit marked up map(s) showing the position of unmapped and incorrectly positioned manhole(s) and/or pipelines discovered during the work. All map(s) shall be marked up with red text and delivered to the Engineer upon the completion of each sewershed. Supplemental sketches shall also be provided in red text, as necessary to clearly depict the actual site conditions including, but not limited to congested areas and established access roads. A legend shall be added to the title block indicating the symbology, color coding and descriptions. The date, the words "As-Built" and company name shall also be included in the title block.

END OF SECTION

**ATTACHMENT A**



**GPS CERTIFICATION FORM**

The purpose of this form is to provide the City of Atlanta with additional GPS/Survey information necessary to maintain the GIS system. This form should be completed for each sewershed and submitted with the Certified GPS.

Name of Sewershed:	Contractor Name: Contact Number:	Surveyor Name: Contact Number:
Brief description of survey equipment used: (Manufacturer, Model No., Age)		
Reference Coordinate System used a. Horizontal <ul style="list-style-type: none"> <li>• Datum _____</li> <li>• Adjustment _____</li> <li>• Coordinate System _____</li> <li>• Unit of Measure _____</li> </ul> b. Vertical <ul style="list-style-type: none"> <li>• Datum _____</li> <li>• Geoid Model _____</li> <li>• Unit of Measure _____</li> </ul> c. Geodetic monuments used or name of network RTK service _____		
d. Scale factors for Conventional Survey _____		
e. If calibration or transformation was applied, list parameters _____		
f. Are coordinates Grid or Ground? _____		

\_\_\_\_\_  
 Signature and Seal of Surveyor

\_\_\_\_\_  
 Date

(This page is intentionally blank)

---

**SECTION 02000**

**SITE WORK**

**PART 1 GENERAL**

**1.01 SCOPE**

- A. This section outlines site work requirements that are applicable to all site work operations. Refer to specification sections for specific product and execution requirements.

**1.02 QUALITY ASSURANCE**

- A. Comply with all applicable local, state, and federal requirements regarding materials, methods of work, and disposal of excess and waste materials.
- B. Obtain and pay for all required inspections, permits, and fees. Provide notices required by governmental authorities.

**1.03 PROJECT CONDITIONS**

- A. Locate and identify existing underground and overhead services and utilities within contract limit work areas. Provide adequate means of protection of utilities and services designated to remain. Repair utilities damaged during site work operations at Contractor's expense.
- B. Arrange for disconnection or disconnect and seal or cap all utilities and services designated to be removed before start of site work operations. Perform all work in accordance with the requirements of the applicable utility company or agency involved.
- C. When uncharted or incorrectly charted underground piping or other utilities and services are encountered during site work operations, notify the Engineer and the applicable utility company immediately to obtain procedure directions. Cooperate with the applicable utility company in maintaining active services in operation.
- D. Locate, protect, and maintain bench marks, monuments, control points and project engineering reference points. Reestablish disturbed or destroyed items at Contractor's expense.
- E. Perform site work operations and the removal of debris and waste materials to assure minimum interference with streets, walks, and other adjacent facilities.

- F. Obtain governing authorities' written permission when required to close or obstruct street, walks and adjacent facilities. Provide alternate routes around closed or obstructed traffic ways when required by governing authorities.
- G. Control dust caused by work. Dampen surfaces as required. Comply with pollution control regulations of governing authorities.
- H. Protect existing buildings, paving, and other services or facilities on site and adjacent to the site from damage caused by site work operations. Cost of repair and restoration of damaged items at Contractor's expense.
- I. Protect and maintain street lights, utility poles and services, traffic signal control boxes, curb boxes, valves and other services, except items designated for removal. Remove or coordinate the removal of traffic signs, parking meters and postal mail boxes with the applicable governmental agency. Provide for temporary relocation when required to maintain facilities and services in operation during construction work.
- J. Preserve from injury or defacement all vegetation and objects designated to remain.

## **PART 2 PRODUCTS**

### **2.01 MATERIALS AND EQUIPMENT**

- A. Materials and equipment: As selected by Contractor, except as indicated in contract documents.

## **PART 3 EXECUTION**

### **3.01 GENERAL**

- A. Examine the areas and conditions under which site work is performed. Do not proceed with the work until unsatisfactory conditions are corrected.
- B. Consult the records and drawings of adjacent work and of existing services and utilities which may affect site work operations.

**+ + + END OF SECTION 02000 + + +**

---

**SECTION 02112****Route Clearing****PART 1 – GENERAL****1.01 SCOPE**

- A. The extent of route clearing is that minimum degree of clearing necessary to carry out construction activities such as pipe bursting, pipe repairs and other pipeline renewal processes including construction of appurtenances, as well as other additional clearing needed for access purposes.
- B. The Contractor shall endeavor to minimize disruption to the neighborhood and shall adjust route-clearing plans to avoid important landscaping features where practicable.
- C. Route clearing operations include, but are not limited to, the following:
  - 1. All coordination, permitting, plan development and submittals, and other associated items in accordance with the City of Atlanta's Tree Protection Ordinance and Greenway requirements.
  - 2. Notification of the One Call Center for location and marking of existing utilities within the work zone
  - 3. Erosion control of disturbed areas
  - 4. Protecting trees, plants, buffers, and above-grade and underground improvements
  - 5. Removal and disposal of debris, trees and other vegetation
  - 6. Clearing
  - 7. Removing above-grade improvements
  - 8. Removing underground improvements
  - 9. Restoring damaged improvements

**1.02 QUALITY ASSURANCE**

- A. The Contractor shall comply with applicable codes, ordinances, rules, regulations and laws of local, municipal, state or federal authorities having jurisdiction over the Project. All required permits of a temporary nature,

including coordination with local officials, plans development and approval, submittals, etc., shall be obtained for construction operations by the Contractor.

- B. Burning of cleared materials on site is not permitted. The Contractor shall allow in rates for complete removal of all material arising from any necessary clearing and grubbing.
- C. Protection of Existing Improvements:
1. Provide barricades, coverings, or other types of protection necessary to prevent unnecessary damage to existing improvements.
  2. Protect improvements on adjoining properties as well as those on the project site. Restore improvements damaged by this work to their original condition, as acceptable to the Owners or other parties or authorities having jurisdiction. Replace property line monuments (such as iron pins) removed or disturbed by clearing operations. This work shall be performed by a Land Surveyor licensed in the State of Georgia.
- D. Protection of Existing Trees and Vegetation:
1. Protect existing trees and other vegetation against unnecessary cutting, breaking or skinning of roots, skinning and bruising of bark, smothering of trees by stockpiling construction materials or excavated materials within drip lines, excess foot or vehicular traffic, or parking of vehicles or equipment within drip line. Provide temporary fences, barricades or guards as required to protect trees and vegetation to be left standing.
  2. Provide protection for tree roots over 1-1/2 inches diameter that are cut during any construction operation. Coat the cut faces with emulsified asphalt, or other acceptable coating, especially formulated for horticultural use on cut or damaged plant tissues. Temporarily cover all exposed roots of trees with wet burlap to prevent roots from drying out; provide earth cover as soon as possible.
  3. Repair or replace unnecessarily damaged trees and vegetation, as determined by the Engineer/City Arborist and/or Planning Department, resulting from any construction operation, in a manner acceptable to the property owner and the Engineer. A qualified nurseryman shall perform tree damage repair. Replace unnecessarily damaged trees that cannot be repaired and restored to full-growth status, as determined by the tree surgeon. Replace felled trees in accordance with the approved plan.



E. Protection of Adjacent Property:

1. Protect improvements, trees and vegetation on adjoining property as well as those on property requiring route-clearing work.
2. Execute work so as not to create a nuisance to any person including persons utilizing adjacent property.
3. Use work methods and provide temporary facilities as necessary to prevent washing, erosion, siltation or dust damage, or hazard to persons and property, within and off the work area.

## **PART 2 – PRODUCTS**

### **2.01 EQUIPMENT**

- A. The Contractor shall furnish equipment of the type normally used in clearing and grubbing operations including, but not limited to, tractors, trucks, loaders, mowers and clippers.

## **PART 3 – EXECUTION**

### **3.01 CLEARING**

- A. Route clearing operations shall begin no more than seven days before beginning construction work for any area.
- B. Materials to be cleared, grubbed and removed from the project site include but are not limited to vegetation, trees, stumps, roots, lawns, shrubbery, gardens, paving, miscellaneous structures, debris, and abandoned utilities to the minimum practicable extent to complete the work. Limit clearing to a single lane work route without provision for construction vehicles to pass utility operation. Accurately determine limitations of construction easement or right-of-way, and keep construction activity within such limits.
- C. Grubbing shall consist of completely removing roots, stumps, trash and other debris from all graded areas so that topsoil is free of roots and debris. Topsoil is to be left sufficiently clean so that further picking and raking will not be required.
- D. All stumps, roots, foundations and planking embedded in the ground shall be removed and disposed of. Piling and butts of utility poles shall be removed to a minimum depth of two feet below the limits of excavation for

structures, trenches and roadways or two feet below finish grade, whichever is lower.

- E. Landscaping features shall include, but are not necessarily limited to: fences, cultivated trees, cultivated shrubbery, property corners, man-made improvements, subdivision and other signs shall be moved off the easement. The Contractor shall take extreme care in moving landscape features and shall re-establish these features as directed by the Engineer.
- F. Surface rocks and boulders shall be grubbed from the soil and removed from the site if not suitable as Rip Rap.
- G. Where tree limbs interfere with utility wires, or where the trees to be felled are in close proximity to utility wires, the tree shall be taken down in sections to eliminate the possibility of damage to the utility.
- H. Any work pertaining to utility poles shall comply with the requirements of the appropriate utility.
- I. All fences adjoining any excavation or embankment that, in the Contractor's opinion, may be damaged or buried, shall be carefully removed, stored and replaced. Any fencing that, in the Engineer's opinion, is significantly damaged shall be replaced with new fence material of equal or better quality and construction.
- J. Stumps and roots shall be grubbed and removed to a depth not less than two feet below grade. All holes or cavities which extend below the subgrade elevation of the proposed work shall be filled with crushed rock or other suitable material, compacted to the same density as the surrounding material.
- K. The Contractor shall exercise special precautions for the protection and preservation of trees, cultivated shrubs, sod, fences, etc. situated within the limits of any temporary easements, but not directly within the permanent easements. The Contractor shall be held liable for any damage the Contractor's operations have inflicted on such property.
- L. The Contractor shall be responsible for all damages to existing improvements outside the permanent easement resulting from Contractor's operations.
- M. Remove lawn sod by cutting into maximum size which can be handled without tearing, stripping sod and underlying topsoil, and stockpiling for use in restoring the surface area. Water sod and otherwise maintain sod in viable, growing condition. Alternative means of lawn sod replacement may be considered by the Engineer.
- N. Remove above-grade structures only where specifically authorized.

- O. Remove conflicting fences and provide effective, temporary measures to prevent domestic animals from wandering to other lands. Reconstruct fences promptly.
- P. Remove abandoned underground facilities such as utilities and structures, walls, footings, basements, wells, septic tanks, cisterns, underground pipe, and other items which conflict with construction.

### **3.02 HOLES AND DEPRESSIONS**

- A. Fill holes, depressions and voids created or exposed by clearing operations with non-organic soil material, unless further excavation or earthwork is indicated.
- B. Place fill material in horizontal layers not exceeding six inches loose-depth and thoroughly compact to a density at least equal to adjacent original ground.

### **3.03 DISPOSAL OF WASTE MATERIALS**

- A. Disposal General Requirements: Accomplish disposal of cleared matter daily so as to maintain site in a safe and neat condition throughout the contract period. Owners of the property may remove merchantable timber, buildings or other items of value from the work site before the Contractor begins operations, and no assurance exists that any such material will be on the work site when the Contractor begins work.
- B. On-Site Disposal:
  - 1. On undeveloped property, grind trees, limbs and brush into mulch and distribute within the work area from which cut, in such a way as not to be objectionable to the property owner. Properly dispose of all materials not utilized for mulch off-site. On developed property, remove all such clearing waste and properly dispose of it off-site.

### **3.04 DISPOSAL OF DEBRIS**

- A. The debris resulting from the clearing and grubbing operation shall be hauled to a disposal site secured by the Contractor and shall be disposed of in accordance with all requirements of federal, state, county and municipal regulations. Except that debris utilized as mulch, no debris of any kind shall be deposited in any stream or body of water, or in any street or alley. No debris shall be deposited upon any private property except with written consent of the property owner. In no case shall any material or debris of

any kind be left on the Project, shoved onto abutting private properties or buried on the Project.

### **3.05 CONSTRUCTION ACCESS ROUTE ON EASEMENT**

- A. When directed by the Engineer, a construction access route shall be built on the sewer easement for the purpose of accessing manholes and performing all other necessary work within the easement.
- B. Construction access route shall be cut (10) ten feet wide, minimum, and (6) six inches deep below existing grade. Filter fabric shall be placed at the bottom of the cut, and surge stone shall be placed on top of the fabric, filling the six inch depth along the roadway.
- C. The filter fabric for use under the stone shall be as specified in Section 02125.
- D. Surge stone shall be 4” to 6” size (4X6) rip rap type stone, or equivalent. Use sound, tough, durable stones resistant to the action of air and water. Slabby or shaley pieces will not be acceptable. Specific gravity shall be 2.0 or greater. Stones shall have less than 66 percent wear when tested in accordance with AASHTO T-96.

### **3.06 TREE REMOVAL ON EASEMENTS**

- A. The contractor shall conform to the requirements of the City of Atlanta’s Tree Protection Ordinance before work commences
- B. The Engineers approval shall be obtained prior to the removal of any trees from the easement. Such concurrence shall be obtained in writing.
- C. The approval of the Engineer concerning the method and location of disposal of materials must be agreed with the owner and engineer before work commences.
- D. All trees that need further processing (wood chips) on-site or disposal off-site must be processed or disposed of in conformance with Federal, State, and local rules and regulations.
- E. Contractor shall ensure all utilities are located prior to the commencement of any clearing or construction work in the easement.
- F. Contractor must acquire any necessary permits prior to commencement of any type of work done in the easement especially for the removal of trees and crossing of waterways.

- G. Trees shall be felled into the cleared construction area or areas to be cleared and not onto vegetation to be preserved.
- H. Trees that have fallen into water bodies, or beyond the construction area, shall be removed immediately.

END OF SECTION

(This page is intentionally blank)

---

**SECTION 02125**

**Erosion and Sedimentation Control**

**PART 1 – GENERAL**

**1.01 SCOPE**

- A. The work specified in this Section consists of providing, maintaining and/or removing temporary erosion and sedimentation controls and providing and installing permanent erosion control measures, all as shown on the Contract Drawings and specified herein
- B. Erosion and sediment controls include all appropriate techniques and materials as described in Chapter 6 of the “Manual for Erosion and Sediment Control in Georgia”, published by the Georgia Soil and Water Conservation Commission (4310 Lexington Road, Athens, GA 30603, also available for free download on line at [www.gaswcc.org](http://www.gaswcc.org)) and as modified or enhanced in the Contract Specifications and Drawings.
- C. All erosion and sediment control facilities shall be designed based on a 25-year, 24-hour rainfall event unless otherwise noted or directed by the Engineer.

**1.02 RELATED SECTIONS**

- A. This Section references the following related Specification Sections:
  - 02270 – Vegetative Erosion Control
  - 02271 – Gabions
  - 02273 – Riprap
  - 03300 - Cast-In-Place Concrete

**1.03 SUBMITTALS AND PERMITS**

- A. Furnish submittals in accordance with General Conditions Section GC-28, Working Drawings, Shop Drawings, Data on Material and Equipment, Samples and Licenses, and Manual for Erosion And Sediment Control in Georgia.
- B. Submittals and Permits:

Within 15 days after the date of the Notice to Proceed, the Contractor shall submit a written description, drawings and schedule for typical applications of proposed temporary erosion and sedimentation controls through City of Atlanta’s Bureau of Buildings to acquire a blanket Land Disturbance Permit (via the Site Development Department of the City of Atlanta’s Department of

Watershed Management), and shall submit the documents to the Engineer for review. The description, drawings and schedule shall meet the requirements of the Georgia Erosion and Sedimentation Act of 1975 (OCGA 12-7-1), as amended, (available from the Environmental Protection Division of the Georgia Department of Natural Resources at 4244 International Parkway, Suite 114, Atlanta, GA 30354, also available for free download on line at <http://www.gadnr.org/>), the Rules of Georgia Department of Natural Resources Environmental Protection Division, Chapter 391-3-7 “Erosion and Sedimentation Control” (available from the Environmental Protection Division of the Georgia Department of Natural Resources at 4244 International Parkway, Suite 114, Atlanta, GA 30354, also available for free download on line at <http://www.gadnr.org/>) and the City of Atlanta’s Code of Ordinances, Part II, Chapter 74, Article II “Land Disturbing Activities” (available from the City of Atlanta at 55 Trinity Avenue, Suite 4100 Atlanta, Georgia 30303, also available for free download on line at [www.atlantaga.gov/](http://www.atlantaga.gov/)). The Contractor shall pay any required fees for the Land Disturbance Permit. Land disturbance activity shall not commence until the Land Disturbance Permit is issued. The Engineer will provide reproducible plan sheets to the Contractor for Contractor's use. The reproducible plan sheets will not bear the Engineer's seal or logo and is provided only for the Contractor's convenience in obtaining the land disturbance permit. The Contractor shall be responsible for submitting to the Bureau of Buildings necessary and sufficient documentation to enable issuance of a permit. All fines imposed for violating the terms of the permit shall be paid by the Contractor at no additional cost to the Owner.

- C. The written description, drawings and schedule shall indicate typical erosion and sediment controls for typical land disturbing activities that will ensure stormwater and site drainage from the temporarily disturbed areas shall be filtered or otherwise managed to minimize impacts on receiving waters and/or existing storm drain systems.
- D. The description, drawings and schedule shall include both temporary and permanent seedings. The submittal shall include selection of grass species (minimum of two cool season and two warm season for temporary and permanent stabilization), planting dates and rates of application for seed, agricultural lime, fertilizer and mulching.
- E. The contractor shall designate a Level 1-A certified worksite erosion control supervisor (WECS). The WECS shall be available on a 24-hour basis, 7-days per week and shall be available on site at all times during land disturbing activities, have the responsibility and authority to coordinate all equipment, personnel, and materials needed to maintain project site erosion control in accordance with the management practices and standards established in Chapter 6 of the “Manual for Erosion and Sediment Control for Georgia”, relevant permits, and the Contract Specifications and Drawings. Within 15 days after the date of Notice to



Proceed, the Contractor shall submit the name and contact phone number(s) of its appointed WECS.

#### **1.04 IMPLEMENTATION**

- A. Erosion and sedimentation control measures shown on the Contract Drawings are minimum requirements. The Contractor's methods of operation may dictate additional erosion and sedimentation control measures above and beyond those which are shown on the Contract Drawings and it shall be the Contractor's responsibility to determine and install such measures. The Contractor's failure to stabilize disturbed areas immediately following intermediate or final grading may dictate additional erosion and sedimentation control measures not shown on the Drawings and it shall be the Contractor's responsibility to determine and install such measures.
- B. The Contractor shall notify the Engineer of any changes and/or additions to the erosion and sedimentation control plan necessary to accommodate the Contractor's methods of operation. No additional payment shall be made for erosion and sedimentation control measures made necessary by the Contractor's methods of operation.
- C. The Contractor shall be solely responsible for control of erosion and sediment production within the project area boundaries and prevention of sedimentation of any adjacent waterways.
- D. The Contractor shall install controls that will ensure that stormwater and drainage from the disturbed area of the Project site shall be filtered or otherwise managed to minimize impacts on receiving waters and/or existing storm drain systems. Discharged waters shall, upon visual inspection, be reasonably free of soil particles and shall meet all applicable permit turbidity requirements. The Contractor shall be responsible for all water quality testing mandated by applicable permits.
- E. The Contractor shall be responsible for keeping the project site sufficiently moist to control dust.

#### **1.05 QUALITY ASSURANCE**

- A. General: Perform all work under this Section in accordance with all pertinent rules and regulations including, but not necessarily limited to, those stated in the applicable permits and the Contract Specifications.
- B. Conflicts: Where provisions of pertinent rules and regulations conflict with each other or these Specifications, the more stringent provisions shall govern. PART 2 – PRODUCTS

## 2.01 GENERAL

- A. All materials shall be as described in Chapter 6 of the “Manual for Erosion and Sediment Control in Georgia” (referenced above) and as modified herein.
- B. See Specification Section 02270 - Vegetative Erosion Control for additional vegetative materials and techniques used for erosion and sediment control. Materials and techniques covered by Section 02270 include mulching, seeding, sodding, and erosion control blankets and matting as well as other stabilization methods.
- C. Netting shall be 1/2-inch mesh, galvanized steel, chicken wire.
- D. Geotextile for use under gabions, riprap, or other stone structures not designed for vehicle traffic shall be Mirafi “Filterweave 403” or approved equal.
- E. Geotextile for use under construction exits or other stone structures designed for vehicle traffic shall be Mirafi “600X” or approved equal
- F. Plywood shall be 3/4-inch thick exterior type.
- G. Grout, where required, shall be composed of 1 part Portland Cement and 3 parts sand and mixed with water to a workable consistency.

## 2.02 SEDIMENT BARRIER

- A. Types A, B, and C silt fences shall meet the corresponding requirements of Section 171 - Temporary Silt Fence of the Department of Transportation, State of Georgia, Standard Specification Construction of Roads and Bridges, latest edition, as referenced in the “Manual for Erosion and Sediment Control in Georgia” (Standard Specification Book available at: GDOT, 2 Capitol Square, Room 215 – Contracts Administration, Atlanta, GA, 30334, 404-656-5293)
- B. Silt fence fabric for Type A and B fences shall be Mirafi “FF 100” or approved equal. Silt fence fabric for Type C fences shall be Mirafi “Filterweave 402” or approved equal.
- C. Hay bales shall be clean, weed-free cereal hay 80 to 100 pounds or larger.

### **2.03 RIP RAP**

- A. See Specification Section 02273 - Riprap for riprap material requirements.
- B. Unless otherwise shown or noted riprap shall be Type 3, as defined in Section 02273.

### **2.04 GABIONS (Not Used)**

### **2.05 CONCRETE**

- A. See Specification Section 03300 – Cast-In-Place Concrete for concrete material requirements.

## **PART 3 – EXECUTION**

### **3.01 BASIC PRINCIPLES**

- A. Conduct the earthwork and excavation activities in such a manner to follow existing contours and consider soil type and condition.
- B. Minimize the disturbed area and the duration of exposure to erosion elements.
- C. Stabilize disturbed areas immediately with the most efficient and effective erosion control measures..
- D. Safely convey run-off from the site to an outlet such that erosion will not be increased off site.
- E. Retain sediment on site that was generated on site.
- F. Minimize encroachment upon watercourses.

### **3.02 GENERAL**

- A. Provide all materials and promptly take all actions necessary to achieve effective erosion and sedimentation control in accordance with the Georgia Erosion and Sedimentation Act of 1975, as amended, Rules of Georgia Department of Natural Resources Environmental Protection Division, Chapter 391-3-7 “Erosion and Sediment Control”, and the City of Atlanta’s Code of Ordinances, Part II, Chapter 74, Article II “Land Disturbing Activities”. The Contractor shall follow the Best Management Practices as described in Chapter 6 of the “Manual for Erosion and Sediment Control in Georgia” and as modified in these Specifications.

- B. Silt dams, silt fences, traps, barriers, check dams, appurtenances and other measures and devices shall be installed as indicated on the Contract Drawings and as required by applicable permits, shall be maintained until no longer needed, and shall then be removed. Deteriorated hay bales and dislodged filter stone shall be replaced with new materials. Detention ponds, if constructed, shall be maintained in a condition ensuring that unfiltered water will not leave the pond.
- C. Where the Contractor's erosion and sedimentation control practices are inadequate, the Engineer may direct the Contractor to provide temporary vegetative cover with fast growing seedings. Such temporary vegetative cover shall be provided by the Contractor in compliance with the Manual for Erosion and Sedimentation Control in Georgia, specifically in the selection of grass species, planting dates and application rates for seed, fertilizer, agricultural lime, and mulching, with the exception that kudzu shall not be permitted.
- D. All erosion and sedimentation control devices, including check dams, shall be inspected by the Contractor at least weekly and after each rainfall occurrence and cleaned out and repaired by the Contractor as necessary.
- E. Temporary erosion and sedimentation control devices shall be installed and maintained from the initial land disturbance activity until the satisfactory completion and establishment of permanent vegetation. At that time, temporary devices shall be removed. Removal of sediment and erosion control measures shall be approved by the Engineer and shall not disturb established vegetation.
- F. Permanent erosion control measures shall be implemented as soon as practical after the completion of pipe installation or land disturbance for each site. In no event shall implementation be postponed when no further construction activities will impact that portion or segment of the Project. Partial payment requests may be withheld for those portions of the Project not complying with this requirement.
- G. If a location is indicated or noted on the Contract Drawings, dispose of all excess sediment removed from temporary erosion and sediment control devices on site as indicated. Where no on-site disposal is indicated or suitable, the sediment shall be hauled off site to an appropriate disposal location arranged by the Contractor and at its sole expense.
- H. See Specification Section 02270 - Vegetative Erosion Control for vegetative erosion and sediment control methodology including mulching, seeding, sodding, and erosion control blankets and matting as well as other stabilization methods.

- I. All excess materials and removed materials shall be removed from the site immediately after they are no longer in use.

### **3.03 CHECK DAM**

- A. Install and maintain check dam as indicated in the Manual for Erosion and Sediment Control in Georgia, and as modified in these specifications and as shown on the Drawings.
- B. Check dams shall be constructed to be stable throughout their planned life. The dam shall be constructed well into the abutment so that water cannot run around the dam.
- C. Haybale check dams may be used as temporary check dams in concentrated flow areas while vegetation is becoming established. Haybale check dams shall not be used where the drainage area exceeds 1 acre. The haybales shall be embedded a minimum of 4 inches on its upslope side.
- D. Periodic inspection of check dams is necessary. Repair shall be made as soon as possible to minimize damage and expense of repair. Sediment shall be removed when it reaches a depth of one-half the original dam height.
- E. Whenever check dams are removed, care shall be taken to minimize disturbance to the remainder of the watercourse. The area where the check dam was removed shall be immediately shaped and smoothed to watercourse dimensions, seeded and mulched.

### **3.04 SILT FENCE**

- A. Install and maintain silt fence as indicated in the Manual for Erosion and Sediment Control in Georgia, and as modified in these specifications and as shown on the Drawings.
- B. The filter fabric shall have an approved color mark yarn woven into the fabric or the manufacturer label and fabric name printed on the fabric every 100 feet.
- C. Post installation shall start at the center of the low-point (if applicable) with the remaining posts spaced 6 feet apart for Type A and B silt fences and 4 feet apart for Type C silt fence. Wood and steel post may be used with Type A and Type B silt fences. Only steel post shall be used with Type C silt fence. For post size requirement see the latest edition of the Manual for Erosion and Sediment Control in Georgia.

- D. Securely fasten geotextile to each support post in a way that will not result in tearing of geotextile when fence is subjected to service loads. The filter fabric shall be securely fastened to the fencing with staples or nails or other fasteners made for this purpose. The bottom of the filter fabric shall be installed in a toe trench. The toe trench shall then be filled with the soil and compacted.
- E. Install geotextile fabric in one piece or continuously sewn to make one piece, for full length and height of fence, including portion of geotextile buried in toe trench.
- F. Along stream buffers and other sensitive areas, two rows of Type C silt fence or one row of Type C silt fence backed by haybales shall be used.
- G. Silt fences shall be inspected immediately after each rainfall and at least weekly during normal construction activities and daily during prolonged rainfall. Any needed repairs shall be made immediately. Promptly repair or replace silt fence that becomes damaged, unfastened or slumps.
- H. Sediment deposits shall be removed when the deposits reach one-half the original height of the silt fence. Any sediment deposits remaining after the sediment barrier is no longer required shall be smoothed to conform to the natural topography and the area restored.

### **3.05 HAY BALES**

- A. Install and maintain hay bales as indicated in the Manual for Erosion and Sediment Control in Georgia, and as modified in these specifications and as shown on the Drawings.
- B. Bales shall be placed lengthwise on the contour in a single row and embedded in the soil a minimum depth of 4 inches. Bales shall be securely anchored in place by stakes, bars or other acceptable means. Stakes for hay bale barriers shall be nominal 2 inch by 2 inch wood. The wood shall be sound with a minimum length of 3 feet. The stakes shall be driven into the ground 18 to 24 inches. Equivalent metal rods or steel bars may be used.
- C. Hay bales shall be inspected immediately after each rainfall and at least weekly during normal construction activities and daily during prolonged rainfall. Any needed repairs shall be made immediately.
- D. Sediment deposits shall be removed when the deposits reach one-half the original height of the hay bales. Any sediment deposits remaining after the sediment barrier is no longer required shall be smoothed to conform to the natural topography and the area restored as specified in the Contract Documents.

### 3.06 INLET SEDIMENT TRAP

- A. Install and maintain inlet sediment traps as indicated in the Manual for Erosion and Sediment Control in Georgia, and as modified in these specifications and as shown on the Drawings.
- B. Sediment traps shall be constructed on natural ground surface, on an excavated surface, or on machine compacted fill provided they have a non-erodible outlet.
- C. Fabric Frame Inlet Sediment Traps: Filter fabric fitted around a supporting frame shall be used for inlet protection where the inlet drains a relatively flat area (slope no greater than 5 percent) and the inlets do not receive concentrated flows. The frame shall be constructed from Type C silt fence filter fabric supported by steel posts. Stakes shall be spaced evenly around the perimeter of the inlet a maximum of 3 feet apart and securely driven into the ground approximately 18 inches deep. The fabric shall be entrenched 12 inches and backfilled with crushed stone or compacted soil. Fabric shall be securely fastened to the posts, and fabric ends shall be overlapped a minimum of 18 inches or wrapped together around a post.
- D. Baffle Box: A baffle box inlet sediment trap shall be used for inlets receiving runoff with a higher volume or velocity. The baffle box shall be constructed of 2" x 4" boards spaced a maximum of 1 inch apart or of plywood with weep holes. The weep holes shall be 2 inches in diameter spaced approximately 6 inches on center vertically and horizontally. The entire box shall be wrapped in Type C silt fence filter fabric. The filter fabric shall be entrenched 12 inches and backfilled. Gravel shall be placed outside the box, all around the inlet, to a depth of 2 to 4 inches.
- E. Block and Gravel Drop Inlet Sediment Traps: Block and gravel drop inlets shall be used where heavy flows are expected and where an overflow capacity is necessary to prevent excessive ponding around the structure. On each side of the structure one block, in the bottom row, shall be placed on its side to allow the pool to drain. The foundation shall be excavated at least 2 inches below the crest of the storm drain. The bottom row of blocks shall be placed against the edge of the storm drain for lateral support and to avoid washouts when overflow occurs. When needed, lateral support shall be provided to subsequent rows by placing 2" x 4" wood studs through the block openings. To hold gravel in place, hardware cloth or comparable wire mesh with ½ inch openings shall be carefully fitted over all block openings. Clean gravel shall be placed to a height of 2 inches below the top of the block on a 2:1 slope or flatter and smoothed to an even grade. Georgia DOT #57 washed stone is recommended.

- F. Gravel Drop Inlet Sediment Traps: Gravel drop inlet protection shall be used where heavy concentrated flows are expected. The slope toward the inlet shall be no steeper than 3:1. To prevent gravel from entering the inlet, an area of level stone, that is a minimum of 1 foot wide, shall be placed between the structure and around the inlet. Stone that is 3 inches or larger in diameter shall be used on the slope toward the inlet. On the slope away from the inlet, #57 ( $\frac{1}{2}$ " to  $\frac{3}{4}$ " diameter) washed stone shall be placed in a layer at least one foot (1') thick.
- G. Sod Inlet Protection: Sod inlet protection shall be used at the time of permanent seeding to protect inlets from sediment and mulch material until the permanent vegetation becomes established. The sod shall be placed to form a turf mat covering the soil for a distance of 4 feet from each side of the inlet structure. Sod strips shall be staggered so that adjacent strip ends are not aligned.
- H. Sediment traps shall be inspected daily and after each rain. Repairs shall be made as needed. Sediment shall be removed when the sediment has accumulated to one-half the height of the trap. For excavated inlet sediment traps, sediment shall be removed when one-half the storage capacity has been lost due to sediment accumulation. Sediment that is removed from sediment traps shall be properly disposed of and stabilized so that it will not enter the inlet or any waters bodies. Sediment shall not be washed into the inlet. Sod inlet protection shall be maintained as specified in the latest edition of the Manual for Erosion and Sediment Control in Georgia.
- I. Sediment traps shall be removed when the contributing drainage area has been adequately stabilized. All materials and any unstable soil shall be salvaged or properly disposed of. The disturbed area shall be brought back to proper grade then smoothed and compacted. All bare areas around the inlet shall be permanently stabilized.

### **3.07 TEMPORARY STREAM CROSSING**

- A. Install and maintain temporary stream crossings as indicated in the Manual for Erosion and Sediment Control in Georgia, and as modified in these specifications and as shown on the Drawings.
- B. The area under the embankment shall be cleared, grubbed, and stripped of any vegetation and root mat. To facilitate cleanout, the pool area shall be cleared.
- C. Fill material for the embankment shall be free of roots or other woody vegetation, organic material, large stones, and other objectionable material. The embankment shall be compacted in 8-inch layers by



traversing with construction equipment.

- D. The earthen embankment shall be seeded with temporary or permanent vegetation within 7 days of construction.
- E. Construction operations shall be carried out in such a manner that erosion and water pollution are minimized.
- F. All cut and fill slopes shall be 2:1 or flatter.
- G. Temporary sediment traps shall be inspected after each period of significant rainfall. Sediment shall be removed and the trap restored to its original dimensions when the sediment has accumulated to one-half the design depth of the trap. The sediment removed shall be placed in the designated disposal area. The contaminated part of the gravel facing shall be replaced.
- H. The structure shall be checked for damage from erosion or piping. The depth of the spillway shall be checked periodically to ensure it is a minimum of 1.0 ft below the low point of the embankment. Any observed settlement of the embankment shall be filled immediately to slightly above design grade. Any riprap displaced from the spillway shall be replaced immediately.
- I. After all sediment-producing areas have been permanently stabilized, the structure and all unstable sediment shall be removed. The area shall be smoothed to blend with the adjoining areas and restored as specified in the Contract Documents.

### **3.08 RIP RAP**

- A. Refer to Specification Section 02273 - Riprap for general riprap requirements.
- B. Install and maintain riprap for all erosion and sediment control methodologies as indicated in the Manual for Erosion and Sediment Control in Georgia and as specified or modified in the Contract Documents.

### **3.09 GABIONS**

- A. Refer to Specification Section 02271 - Gabions for general gabion requirements
- B. Install and maintain gabions for all erosion and sediment control methodologies as indicated in the Manual for Erosion and Sediment Control in Georgia and as specified or modified in the Contract Documents.

### **3.10 CONCRETE**

- A. Refer to Specification Section 03300 - Cast-In-Place Concrete for general concrete requirements.
- B. Install concrete for all erosion and sediment control methodologies as indicated in the Manual for Erosion and Sediment Control in Georgia and as specified or modified in the Contract Documents.

### **3.11 CONSTRUCTION EXIT**

- A. Construction exits will be constructed and maintained in accordance with the Manual for Erosion and Sediment Control in Georgia as a minimum and/or as specified or modified in the Contract Documents.

END OF SECTION

---

**SECTION 02140**

**Dewatering**

**PART 1 – GENERAL**

**1.01 SCOPE**

- A. The Contractor shall dewater trench and structure excavations, in accordance with the Contract Documents. The Contractor shall secure all necessary permits to complete the requirements of this Section of the Specifications.
- B. Design, construct and maintain all wells, pumps, vacuum systems, sumps, dikes, levees, cofferdams and diversion and drainage channels as necessary to maintain the areas free from water and to protect the areas to be occupied by permanent work from water damage. Remove temporary works after they have served their purpose.
- C. The Contractor shall be responsible for the stability of all-temporary and permanent slopes, grades, foundations, materials and structures during the course of the Contract. Repair and replace all slopes, grades, foundations, materials and structures damaged by water, both surface and subsurface, to the lines, grades, and conditions existing prior to the damage, at no additional cost to the City.

**PART 2 – PRODUCTS (NOT USED)**

**PART 3 – EXECUTION**

**3.01 CARE OF WATER**

- A. Except where the excavated materials are designated as materials for permanent work, material from required excavation may be used for dikes, levees, cofferdams and other temporary backfill.
- B. Furnish, install, maintain, and operate necessary pumping and other equipment for dewatering the various parts of the work and for maintaining the foundation and other parts free from water as required for constructing each part of the work.
- C. Install all drainage ditches, sumps, and pumps to control excessive seepage on excavated slopes, to drain isolated zones with perched water tables and to drain impervious surfaces at final excavation elevation.

- D. Dewater by means that will insure dry excavations, preserve final lines and grades, do not disturb, or displace adjacent soil.
- E. All pumping and drainage shall be done with no damage to property or structures and without interference with the rights of the public, owners of private property, pedestrians, vehicular traffic or the work of other contractors, and in accordance with all pertinent laws, ordinances and regulations.
- F. All dewatering activities shall comply with Specification Section 02125 – Erosion and Sediment Control.
- G. Do not overload or obstruct existing drainage facilities.
- H. After they have served their purpose, Contractor shall remove all temporary protective work at a satisfactory time and in a satisfactory manner. All diversion channels and other temporary excavations in areas where the compacted fill or other structures will be constructed shall be cleaned out, backfilled and processed under the same Specifications as those governing the compacted fill. Fill or grout all temporary-dewatering wells unless otherwise directed by the Engineer.
- I. When the temporary works will not adversely affect any item of permanent work or the planned usage of the Project, the Contractor may be permitted to leave such temporary works in place. In such instances, breaching of dikes, levees, and cofferdams may be required.

### **3.02 DEWATERING**

- A. By the use of well points, pumps, tile drains, or other approved methods, the Contractor shall prevent the accumulation of water in excavated areas. Should water accumulate, it shall be promptly removed.
- B. Excavations shall be continuously dewatered to maintain a ground water level no higher than three to four feet below the lowest point in the excavation. Dewatering systems shall be designed to allow for localized variations in the depth of excavations required to reach a suitable foundation. Dewatering shall be accomplished well enough in advance of excavation to ensure that groundwater is already lowered prior to completing the final excavation to finish subgrade.
- C. All destabilized subgrade conditions caused by inadequate or untimely dewatering operations shall be undercut and backfilled with suitable backfill material at no additional cost to the City.

- D. Piezometric observation wells are required to monitor the ground water level to insure proper dewatering prior to excavation below the static water table. The number of wells required will vary depending on the size and depth of structures.

END OF SECTION

(This page is intentionally blank)

---

**SECTION 02200**

**Earthwork**

**PART 1 – GENERAL**

**1.01 REQUIREMENTS**

- A. This Section includes earthwork and related operations, including, but not limited to: excavating all classes of material encountered; trenching, handling, storage, transportation, and disposal of all excavated and unsuitable material; construction of fills and embankments; backfilling around structures and pipe; backfilling all trenches and pits; compacting; all sheeting, shoring, and bracing; preparation of subgrades; surfacing and grading; and any other similar, incidental, or appurtenant earthwork operation which may be necessary to properly complete the Work.
- B. The Contractor shall provide all services, labor, materials, and equipment required for all earthwork and related operations necessary or convenient to the Contractor for furnishing complete Work as shown on the Drawings or specified in the Contract Documents.

**1.02 RELATED SECTIONS**

- B. The Work of the following Sections specifically apply to the Work of this Section. Other Sections of the Specifications, not referenced below, shall also apply to the extent required for proper performance of Work.
  - 1. Section 01410: Testing Laboratory Services
  - 2. Section 02125: Erosion and Sedimentation Control
  - 3. Section 02140: Dewatering

**1.03 GENERAL**

- A. Safety: Comply with local regulations and with the provisions of the “Manual of Accident Prevention in Construction” of the Associated General Contractors of America, Inc., Occupational Safety and Health Act (OSHA) and all other applicable safety regulations.
- B. Earthwork operations shall be performed in a safe and proper manner with appropriate precautions being taken against all hazards.

- C. All excavated and filled areas for structure, trenches, fills, topsoil areas, embankments and channels shall be maintained by the Contractor in good condition at all times until final acceptance by the City. All damage caused by erosion or other construction operations shall be repaired by the Contractor using material of the same type as the damaged material at no cost to the City.
- D. The Contractor shall control grading in a manner to prevent water running into excavations. Obstruction of surface drainage shall be avoided and means shall be provided whereby storm water can flow uninterrupted in existing open ditches or channels, other surface drains, or temporary drains.
- E. No classification of excavated materials will be made, except for rock excavation. Excavation work shall include the removal and subsequent handling of all materials excavated or otherwise removed in performance of the Work, regardless of the type, character, composition or condition thereof.
- F. All earthwork operations shall comply with the requirements of OSHA Construction Standards, Part 1926, Subpart P, Excavations, Trenching, and Shoring, and Subpart O, Motor Vehicles, Mechanized Equipment, and Marine Operations, and shall be conducted in a manner acceptable to the Engineer.

#### **1.04 CONTRACTOR SUBMITTALS**

- A. The Contractor shall submit samples of all materials proposed to be used in the work in accordance with the requirements in Section GC-28 – Working Drawings, Shop Drawings, Data on Material and Equipment, Samples and Licenses. Sample size shall be as determined by the testing laboratory.
- B. Submittals shall be made in accordance with the requirements of the General Conditions of the Contract Documents. In addition, the following specific information shall be provided:
  - 1. Copies of permits obtained by the Contractor for the work.
  - 2. Test results, certification of compliance, source, and sample for all imported materials.
  - 3. Samples of fill materials to be used: Samples shall be submitted in 2 weeks in advance of use and shall consist of 0.5 cubic feet of each type of material.



## 1.05 QUALITY ASSURANCE

- A. Reference Standard: Comply with all federal, state and local laws or ordinances, as well as all applicable codes, standards, regulations and/or regulatory agency requirements including the partial listing below:
1. ASTM C136-84a Standard Method for Sieve Analysis of Fine and Course Aggregates.
  2. ASTM D1556-82 Test Method for Density of Soils in Place by the Sand-Cone Method.
  3. ASTM D698-78 Test Methods for Moisture-Density Relations of Soils and Soil-Aggregate Mixtures Using 5.5-lb (250-kg) Rammer and 12-in. (305-mm Drop).
  4. ASTM D3017-88 Test Method for Moisture Content of Soil and Rock Aggregate in Place by Nuclear Methods (Shallow Depth).

## PART 2 – PRODUCTS

### 2.01 SUITABLE FILL AND BACKFILL MATERIAL REQUIREMENTS

- A. General: Fill, backfill, and embankment materials shall be suitable selected or processed clean, fine earth, rock, or sand, free from grass, roots, brush, or other vegetation.
- B. Fill and backfill materials to be placed within 6 inches of any structure or pipe shall be free of rocks or unbroken masses of earth materials having a maximum dimension larger than 3 inches.
- C. Suitable Materials: Materials not defined as unsuitable in Section 2.02 are defined as suitable materials and may be used in fills, backfilling, and embankment construction in unpaved areas. In addition, when acceptable to the Engineer, some of the material listed as unsuitable may be used when thoroughly mixed with suitable material to form a stable composite.
- D. Suitable materials may be obtained from on-site excavations, may be processed on-site materials, or may be imported. If imported materials are required by this Section, or to meet the quantity requirements of the project, the Contractor shall provide the imported materials at no additional expense to the City, unless a unit price item is included for imported materials in the bidding schedule.

E. Earthwork Materials:

1. Controlled Fill Soils:

- a. Proposed fill soils shall be laboratory tested prior to construction use to determine their suitability. All material shall be subject to the approval of the Engineer. Testing shall be paid for separately by the City directly to the testing laboratory.
- b. Notification: For approval of imported fill material, notify the Engineering and Testing Laboratory at least three (3) weeks in advance of intention to import material, designate the proposed borrow area, and permit the Testing Laboratory to sample as necessary from the borrow area for the purpose of making acceptance tests to prove the quality of the material. Test results shall be submitted to the Engineer for approval.
- c. All fill material shall be soil exclusive of organic matter, frozen lumps, or other deleterious substances.
- d. It shall contain no rocks or lumps over 3-inches maximum in dimension.
- e. Fill material shall be low to moderate plasticity soil (PI less than 30).

2. Structural Fill and Structural Backfill:

- a. Select on site materials may be suitable. Testing and recommendation of suitability shall be made by the Testing Laboratory and submitted by the Contractor to the Engineer for approval. Testing shall be paid for separately by the City directly to the testing laboratory.
- b. Imported material shall be sand, uniformly graded crushed stone or other select material recommended by the Testing laboratory and submitted by the Contractor to the Engineer for approval. Graded aggregate base material as specified in Section 02575, Removing and replacing pavement, is acceptable.
- c. Crushed Stone: Crushed s used for pipe bedding and drain stone shall conform to the Georgia Department of Transportation Standard Specifications for Construction of Road and Bridges, 800.01 for No. 57 Stone. For concrete, cast iron, steel and galvanized iron pipe less than 12-inch,

use  $\frac{3}{4}$  inch gravel, crushed gravel or crushed stone. For plastic pipe use  $\frac{1}{4}$  -inch pea gravel.

3. Top Soil: Dark organic weed free loam free of muck.
4. Coarse Aggregate: Coarse aggregate shall conform to the Georgia Department of Transportation Standard Specifications for construction of Road and Bridges, 800.01 for No. 57 Stone, Group II, and shall have the following gradation:

Sieve Size	Percent Passing	
1-1/2 inch	100	-
1 inch	95	100
$\frac{3}{4}$ inch	-	-
$\frac{1}{2}$ inch	25	60
#4	0	10
#8	0	5

- F. Sheeting, Bracing, and Timbering: The Contractor shall furnish, place and maintain all sheeting, bracing and timbering required to properly support trenches and other excavations in open cut and to prevent all movements of the soil, pavement, structures, or utilities outside of the trench or pit.

1. General:
  - a. Sheeting, bracing and timbering shall be so placed as to allow the Work to be constructed to the lines and grades shown on the Drawings and as ordered by the Engineer.
  - b. If at any time the method being used by the Contractor for supporting any material or structure in or adjacent to any excavation is not reasonably safe in the opinion of the Engineer, the Engineer may require and the Contractor shall provide additional bracing and support necessary to furnish the added degree of safety required by the Engineer. The Contractor shall provide bracing and support by such methods accepted by the Engineer as Contractor may elect to use, but the taking of such added precautions shall in no way relieve the Contractor of sole and final responsibility for the safety of lives, work, and structures.
  - c. All sheeting in contact with the concrete or masonry shall be removed or cut off and left in place as instructed by the Engineer.

2. Timber:

- a. Timber may be substituted for steel sheet piling when approved by the Engineer. Timber for shoring, sheeting and bracing shall be sound and free of large or loose knots and in good condition. Size and spacing shall be in accordance with OSHA regulations.
- b. Remove bracing and sheeting in units when backfill reaches the point necessary to protect the work and adjacent property. Leave sheeting in place when, in the opinion of the Engineer, it cannot be safely removed. Cut off sheeting left in place below the finished ground surface as instructed by the Engineer.

3. Steel Sheet Piling:

- a. Steel sheet piling shall be the continuous interlock type. The weight, depth and section modulus of the sheet piling shall be sufficient to restrain the loads if earth pressure and surcharge from existing foundations. Procedure for installation and bracing shall be so scheduled and coordinated with the removal of the earth that the ground under existing structures shall be protected against lateral or vertical movements at all times. In addition to the drawings and computations, the Contractor shall provide closure and sealing details between sheet piling and existing facilities, as well as method of excavation within sheet piling to the Engineer for review before commencing construction operations. Contractor shall be responsible for all damage to existing utilities and structures resulting from installation of sheet piling. Damage to existing utilities and/or structures resulting from installation of sheet piling shall be repaired to the satisfaction of the Engineer at the Contractor's expense.

- G. Other Materials: All other materials, not specifically described but required for proper completion of the work of the Section, shall be as selected by the Contractor subject to prior approval of the Engineer.

## 2.02 UNSUITABLE SOIL MATERIAL

A. Unsuitable materials include the materials listed below:

1. Soils, which, when classified under ASTM D 2487 - Standard Classification of Soils for Engineering Purposes (Unified Soil

Classification System), fall in the classifications of Pt, OH, CH, MH, or OL;

2. Soils that cannot be compacted sufficiently to achieve the density specified for the intended use;
3. Materials that contain hazardous or designated waste materials, including petroleum hydrocarbons, pesticides, heavy metals, and any material which may be classified as hazardous or toxic according to applicable regulations;
4. Soils that contain greater concentrations of chloride or sulfate ions, or have a soil resistivity or pH less than the existing on-site soils;
5. Topsoil except as allowed below.

### **2.03 MATERIALS TESTING**

- A. All soils testing of samples will be done by a testing laboratory selected by the City in accordance with Section 01410. Testing shall be paid for by the City. At its discretion, the Engineer may request that the Contractor supply samples for testing of any material used in the Work.
- B. Particle size analysis of soils and aggregates will be performed using ASTM D 422 - Standard Test Method for Particle-Size Analysis of Soils.
- C. Determination of sand equivalent value will be performed using ASTM D 2419 - Standard Test Method for Sand Equivalent Value of Soils and Fine Aggregate.
- D. Unified Soil Classification System: References in this Section to soil classification types and standards shall have the meanings and definitions indicated in ASTM D 2487. The Contractor shall be bound by all applicable provisions of said ASTM D 2487 in the interpretation of soil classifications.
- E. The testing for chloride, sulfate, resistivity, and pH will be done in accordance with ANSI/AWWA C-105/A21.5 Standard.

### **2.04 ROCK EXCAVATION**

- A. Mechanical rock excavation shall include removal and disposal of the following:
  1. All boulders measuring 1/3 of a cubic yard or more in volume;

2. All rock material in ledges, bedding deposits, and un-stratified masses which cannot be removed without systematic drilling and jack-hammering or blasting.
  3. Conglomerate deposits which are so firmly cemented that they possess the characteristics of solid rock and which cannot be removed without systematic drilling and jack-hammering or blasting.
- B. Blasting – See Specification Section 02405.

## **PART 3 – EXECUTION**

### **3.01 EXCAVATION - GENERAL**

- A. General: Except when specifically provided to the contrary, excavation shall include the removal of all materials of whatever nature encountered, including all obstructions of any nature that would interfere with the proper execution and completion of the Work. The removal of said materials shall conform to the lines and grades indicated or ordered. Unless otherwise indicated, the entire construction site shall be stripped of all vegetation and debris, and such material shall be removed from the site prior to performing any excavation or placing any fill. The Contractor shall furnish, place, and maintain all supports and shoring that may be required for the sides of the excavations. Excavations shall be sloped or otherwise supported in a safe manner in accordance with applicable State safety requirements and the requirements of OSHA Safety and Health Standards for Construction (29CFR1926).
- B. Removal and Exclusion of Water: The Contractor shall remove and exclude water, including stormwater, groundwater, irrigation water, and wastewater, from all excavations. Dewatering wells, wellpoints, sump pumps, or other means shall be used to remove water and continuously maintain groundwater at a level at least two feet below the bottom of excavations before the excavation work begins at each location. Water shall be removed and excluded until backfilling is complete and all field soils testing have been completed.
- C. Topsoil:
1. Remove all topsoil to a depth at which subsoil is encountered, from all areas that are to be cut to lower grades or filled.
  2. Topsoil to be used for finish grading may be stored on the site. It shall be piled properly, sloped to drain, and covered.

3. Other topsoil may be used for fill in non-critical areas with prior approval of the Engineer

D. Bracing and Sheeting:

1. Furnish, install, and maintain all sheeting, bracing, and shoring as may be required to properly support the sides of all excavations and to prevent all movement of earth that could in any way injure the work, adjacent property, or workers.
2. Properly support all trenches for piping and duct bank installation so as to conform to all pertinent rules and regulations and these Specifications. All trenches deeper than 5 feet shall be shored unless cut to the angle of repose of the excavated soils.
3. Exercise care in the removal of sheeting, shoring, bracing and timbering to prevent collapse or caving of the excavation faces being supported and damage to the work and adjacent property.
4. Do not leave any sheeting or bracing in the trench or excavation after completion of the work, unless approved or instructed by the Engineer.
5. All sheeting in contact with concrete or masonry shall be removed or cut off and left in place as instructed by the Engineer.

E. Obstructions:

1. Remove and dispose of all trees, stumps, roots, boulders, pavement, pipes, and the like, as required for the performance of the work.
2. Exercise care in excavating around catch basins, inlets, manholes, piping, duct banks, underground vaults, etc.
3. Avoid removing or loosening castings or pushing dirt into structures.
4. Damaged or displaced casting shall be repaired and replaced, and dirt entering the structures during the performance of the work shall be removed at no additional cost to the City.

F. Utilities to be Abandoned:

1. When piped, conduits, sewers or other structures are removed from the trench leaving dead ends in the ground, such ends shall be fully plugged and sealed as indicated on the Drawings.

2. Abandoned structures such as manholes, catch basins, or chambers shall be entirely removed unless otherwise specified or indicated on the Drawings.

### **3.02 HEAVE MONITORING AND CONTINGENCY PLANNING**

- A. Prior to excavation, pipe bursting or directional drilling, the Contractor shall identify any permanent structure, all buried utilities, all natural gas/petroleum pipelines, and any additional structures, which are within a horizontal distance 1.1 times the depth of any excavation deeper than the structure, utility, or natural gas pipeline. This Section does not limit the Contractor's choice of construction methods based on the site conditions.
- B. The Contractor shall perform, at a minimum, daily visual inspections of the perimeter of the pipe burst, drill path or excavation to identify any signs of excessive heave or movement. The results from visual inspections shall be recorded with the daily survey log. Any area, which appears to be excessively deformed or damaged, shall immediately be brought to the attention of the Engineer and be corrected.
- C. The Contractor shall prepare a contingency plan to mitigate the effects of excessive heave, settlement or movement of existing site features. The contingency plan is not to restrict the Contractor from using the best construction methods available to meet the conditions, but is required to demonstrate a reasonable preparedness to mitigate the effects of excessive heave movement or settlement. The following are minimum requirements for a contingency plan:
  1. The Contractor shall prepare a contingency plan, outlining steps to be taken to protect structures, utilities, or gas pipes and stop excessive heave movement or settlement identified by the heave/settlement monitoring program.
  2. The Contractor shall have all material, manpower, equipment, and other items identified in the contingency plan available at all times while excavations are ongoing or excavated areas are open.

### **3.03 STRUCTURE, ROADWAY, AND EMBANKMENT EXCAVATION**

- A. Excavation Beneath Structures and Embankments: Except where otherwise indicated for a particular structure or ordered by the Engineer, excavation shall be carried to the grade of the bottom of the footing or slab. Where indicated or ordered, areas beneath structures or fills shall be over-excavated. The subgrade areas beneath embankments shall be excavated to remove not less than the top 6 inches of native material and where such subgrade is sloped, the native material shall be benched. When such over-excavation is indicated both over-excavation and subsequent backfill to the



required grade shall be performed by the Contractor. When such over-excavation is not indicated, but is ordered by the Engineer, such over-excavation and any resulting backfill will be paid for under a separate unit price bid item if such bid item has been established; otherwise, payment will be made in accordance with a negotiated price. After the required excavation or over-excavation has been completed, the exposed surface shall be scarified to a depth of 6 inches, brought to optimum moisture content, and rolled with heavy compaction equipment to obtain 98 percent of maximum density.

- B. Excavation Beneath Paved Areas: Excavation beneath paved areas shall be provided at minimum dimension shown on the drawings to minimize the disrupted area and volume of backfill required. All backfill material beneath paved areas shall be graded aggregate base material in accordance with Appendix F – Department of Public Works Public Right of Way Manual. The graded aggregate base surface elevation shall be depressed to receive the final pavement surface course as indicated on the Drawings. Controlled low strength flowable fill material may be provided in lieu of graded aggregate base if directed by the Engineer to provide backfill around sensitive or congested utilities or confined excavations where mechanical compaction is not practical.
- C. Notification of Engineer: The Contractor shall notify the Engineer at least 3 days in advance of completion of any structure excavation and shall allow the Engineer a review period of at least one day before the exposed foundation is scarified and compacted or is covered with backfill or with any construction materials.

### **3.04 PIPELINE AND UTILITY TRENCH EXCAVATION**

- A. Exploratory Excavation:
  - 1. The Contractor shall excavate and expose buried points of connection to existing utilities as required by Engineer.
  - 2. Data, including dates, locations excavated, and sketches, shall be submitted to the Engineer within one week of excavation.
  - 3. Damage to utilities from excavation activities shall be repaired by the Contractor at no charge to the City.
- B. General: Unless otherwise indicated or ordered, excavation for pipelines and utilities shall be open-cut trenches with widths as indicated.
- C. Trench Bottom: Except when pipe bedding is required, the bottom of the trench shall be excavated uniformly to the grade of the bottom of the pipe bedding. Excavations for pipe bells and welding shall be made as required.

- D. Minimum Width of Trench: The minimum width of pipe trenches, measured at the crown of the pipe, shall not be less than 24-inches greater than the exterior diameter of the pipe, exclusive of bells. The minimum base width, measured at the invert of the piping, of such trench shall be not less than 24-inches greater than the exterior diameter of the pipe, exclusive of special structures or connections, and such minimum width shall be exclusive of all trench supports.
- E. Maximum Width of Trench: The maximum allowable width of trench for all pipelines measured at the top of the pipe shall be the outside diameter of the pipe (exclusive of bells or collars) plus 24-inches, and such maximum shall be inclusive of all timbers and/or trench boxes, shoring, etc. A trench wider than the outside diameter plus 24-inches may be used without special bedding if the Contractor, at his expense, will furnish pipe of the required strength to carry the additional trench load. Such modifications shall be submitted to the Engineer and approved in writing. Whenever such maximum allowable width of trench is exceeded for any reason, except as provided for on the Drawings or in the Specifications or by the written instruction of the Engineer, the Engineer shall, at his discretion, require that the Contractor, at its own expense for all labor and materials, cradle the pipe in Class “B” concrete, or other approved pipe bedding.
- F. Maximum length of Open Trench: Except by special permission by the Engineer, only that amount of pipe construction will be permitted, including excavation, construction of pipelines, and backfill in any one location, which can be completed in one day; however, maximum length of open trench shall never exceed 100 feet. This length includes open excavation, pipe laying and appurtenant construction and backfill that had not been temporarily resurfaced.
- G. Trench Side Slopes:
1. Temporary trench excavation shall at all times conform to the safety requirements of OSHA.
  2. Loose cobbles or boulders shall be removed from the sides of the trenches before allowing workers into the excavation, or the trench slopes must be protected with screening or other methods. Trench side slopes shall be kept moist during construction to prevent local sloughing and raveling. Surcharge loads due to construction equipment shall not be permitted within 5 feet of the top of any excavated slope.
  3. If the Contractor elects to shore or otherwise stabilize the trench sides, he shall file with the Engineer for review, copies of drawings for same prepared and signed by a Civil Engineer duly registered in the State Georgia before commencing excavation.

- H. Trench Over-Excavation: Where trenches are indicated to be over-excavated, excavation shall be to the depth indicated, and backfill shall be installed to the grade of the bottom of the pipe bedding.
- I. Over-Excavation: When ordered by the Engineer, whether indicated on the Drawings or not, trenches shall be over-excavated beyond the depth and/or width shown or specified. Such over-excavation shall be to the dimensions ordered. The trench shall then be backfilled to the grade of the bottom of the pipe bedding. Over-excavation less than the limits on the Drawings or less than specified shall be done at no increase in cost to the City. When the over-excavation ordered by the Engineer is greater than the limits shown, additional payment will be made to the Contractor. Said additional payment will be made under separate unit price bid items for over-excavation if such bid items have been established; otherwise, payment will be made in accordance with a negotiated price.
- J. Where pipelines are to be installed in embankments, fills, or structure backfills, the fill shall be constructed to a level at least one foot above the top of the pipe before the trench is excavated.
- K. If a moveable trench shield is used during excavation operations, the trench width shall be wider than the shield so that the shield is free to be lifted and then moved horizontally without binding against the trench sidewalls. If the trench walls cave in or slough, the trench shall be excavated as an open excavation with sloped sidewalls or with trench shoring, as indicated and as required by the pipe structural design.

### **3.05 OVER-EXCAVATION NOT ORDERED OR INDICATED**

- A. Any over-excavation beyond the limits shown on the drawings or specified which was not ordered by the City, shall be backfilled to the required grade with the specified material(s) at no additional cost to the City.

### **3.06 EXCAVATION IN LAWN AREAS**

- A. Where excavation occurs in lawn areas, the sod shall be carefully removed, dampened, and stockpiled to preserve it for replacement. Excavated material may be placed on the lawn, provided that a drop cloth or other suitable method is employed to protect the lawn from damage. The lawn shall not remain covered for more than 72 hours. Immediately after completion of backfilling and testing of the pipeline, the sod shall be replaced and lightly rolled in a manner so as to restore the lawn as near as possible to its original condition. Contractor shall provide new sod if stockpiled sod has not been replaced within 72 hours.

### **3.07 EXCAVATION IN VICINITY OF TREES**

- A. Except where trees are indicated to be removed, trees shall be protected from injury during construction operations according to the Tree Protection Plan. No tree roots over 2 inches in diameter shall be cut without express permission of the Engineer. Trees shall be supported during excavation by any means previously reviewed by the Engineer.

### **3.08 ROCK EXCAVATION**

- A. When rock is encountered in trenches, it shall be removed to a minimum depth of six inches (6") below the bell of the pipe.
- B. The rock shall be stripped and measured by the Engineer at five foot (5 ft.) intervals, and the quantity calculated as the actual length multiplied by the average depth multiplied by the average trench width. Trench width shall be a minimum of twenty-four inches (24"), and a minimum of three inches (3") wider on each side of the pipe bell.

### **3.09 DISPOSAL OF EXCESS EXCAVATED MATERIAL**

- A. The Contractor shall remove and dispose of all excavated material in excess of that required to backfill the excavation and to create necessary fills. This shall be done immediately after the backfill is completed to the satisfaction of the Engineer. All materials removed shall become the property of the Contractor, and he shall make his own arrangements satisfactory to the Engineer for their disposition.
- B. All surplus material and such other materials as the Engineer may deem unfit for use as backfill, shall be disposed of by the Contractor so as to give a minimum of inconvenience to the public. In case of settlement after backfill, the Contractor shall supply sufficient material satisfactory to the Engineer to make up for the deficiency.
- C. When so ordered by the Engineer, the Contractor shall immediately remove all excavated materials from the site and dispose of the same.
- D. Any material, which may spill or drip from vehicles by hauling in the streets, shall be removed and the streets cleaned by the Contractor, to the satisfaction of the Engineer, or the proper officials of the municipality in which the hauling or work is being done.
- D. The surface of all graded and spoil areas shall be left in a smooth and level or evenly sloped condition, free from stones, rubbish, or other debris.

### **3.10 SOIL BACKFILL – GENERAL**

- A. Backfill shall not be dropped directly upon any structure or pipe. Backfill shall not be placed around nor upon any structure until the concrete has attained sufficient strength to withstand the loads imposed. Backfill around water retaining structures shall not be placed until the structures have been tested, and the structures shall be full of water while backfill is being placed.
- B. Except for drain rock materials being placed in over-excavated areas or trenches, backfill shall be placed after all water is removed from the excavation, and the trench sidewalls and bottom have been dried to moisture content suitable for compaction.
- C. If a moveable trench shield is used during excavation, pipe installation, and backfill operations, the shield shall be moved by lifting the shield free of the trench bottom or backfill and then moving the shield horizontally. The Contractor shall not drag trench shields along the trench causing damage or displacement to the trench sidewalls, the pipe, or the bedding and backfill.
- D. Immediately prior to placement of backfill materials, the bottoms and sidewalls of trenches and structure excavations shall have all loose sloughing, or caving soil and rock materials removed. Trench sidewalls shall consist of excavated surfaces that are in a relatively undisturbed condition before placement of backfill materials.

### **3.11 SOIL BACKFILL AND FILL PLACEMENT**

- A. Fill shall be placed in loose lifts not exceeding 8-inches in depth and shall be thoroughly compacted as herein specified.
- B. All fill placements may be subject to fill density and moisture tests, which shall be performed to verify that the specified degree of compaction is being achieved. Testing shall be paid for separately by the City directly to the testing laboratory.
- C. Prior to placement of any material in embankments, the area within embankment limits shall be stripped of topsoil and all unsuitable materials removed as described under Excavation. Area to receive fill shall then be scarified to a depth of at least 6-inches.
- D. Fill materials shall be placed in continuous approximately horizontal layers extending the full width of the embankment cross-section and the full dimension of the excavation where practicable.

- E. Fill materials shall be placed within 2 percent of the optimum moisture content. Optimum moisture shall be maintained by sprinkling the layers with water as placed or by allowing material to dry before placement.
- F. Compaction:
1. Fill material shall be compacted to dry densities as determined by the Standard Proctor Compaction Test performed in accordance with ASTM D698. Testing shall be paid for separately by the City directly to the testing laboratory.
  2. Structural fill material supporting structures and pavement and other areas indicated on the Drawings shall be compacted to 95 percent of the maximum dry density. The upper 8" of fill shall be compacted to 95 percent of the maximum dry density.
  3. Controlled fill for general site grading shall be compared to 90 percent of the maximum dry density.
  4. Compaction of embankments shall be by sheepsfoot rollers with staggered uniformly spaced knobs and suitable cleaning devices. The projected area of each knob and the number and spacing of the knobs shall be such that the total weight of the roller and ballast when distributed over the area of one (1) row of knobs shall be 250 psi. Placement and compaction of materials shall extend beyond the final contours sufficiently to insure compaction of the material at the resulting final surface. Final contours shall then be achieved by a tracked bulldozer or grader shaping the face of the embankment.
  5. Compaction of backfill around the structures shall be accomplished by power tamping equipment approved by the Engineer.
  6. If tests indicate that density of backfill is less than that specified, the area shall be re-compacted or undercut, filled, and compacted until specified density is achieved.
- G. Final Grading: Upon completion of construction operations, the area shall be graded to finish contour elevations and grades shown on the Drawings. Graded areas shall be made to blend with remaining ground surfaces. All surfaces shall be left smooth and free to drain.
- H. Moisture:
1. All fill shall be compacted with the moisture content as established by the 95 percent intercept on the moisture density curves or the moisture content at the shrinkage limit, whichever is less.

2. If fill material is too wet, provide and operate approved means to assist the drying of the fill until suitable for compaction
3. If fill material is too dry, provide and operate approved means to add moisture to the fill layers.

I. Proofrolling:

1. All areas where pavement or structures are to be built on compacted fill and other areas where indicated on the Drawings, shall be proofrolled to detect soft spots prior to the placement of fill material or construction of foundations.
2. Proofrolling shall consist of the moving a 20-30 ton loaded dump truck or pneumatic tire roller over the subgrade after the subgrade is shaped. Proofrolling shall be witnessed by the Engineer.
3. Pneumatic-tired rollers shall have not fewer than four pneumatic tired wheels which shall be of such size and ply that tire pressure can be maintained between 80 and 100 pounds per square inch for 25,000 pound wheel load during rolling operations. Unless otherwise required, rolling shall be done with tires inflated to 90 psi. The roller wheels shall be located abreast in a rigid steel frame. Each wheel shall be loaded with an individual weight box so that each wheel will bear an equal load when traversing uneven ground. The weigh boxes shall be suitable for ballast loading such that the load per wheel shall be 25,000 pounds. The spacing of the wheels shall insure that the distance between the nearest edges of adjacent tires shall be not greater than one-half of the tire width of a single tire at the operating pressure for a 25,000 pound wheel load. The roller shall be operated not faster than 5 feet/second.
4. Subgrade shall be proofrolled with 6 passes of the roller. Depressions that develop during the proofrolling operations shall be filled with suitable material and those filled areas shall be proofrolled with 6 passes of the roller. If, after having been filled and proofrolled, the subgrade still contains depressions, the soil shall be undercut to the full depth of the soft material or 5 feet whichever is less, backfilled, and rolled to achieve a subgrade acceptable to the Engineer.
5. After the proofrolled subgrade has been accepted by the Engineer, the surface of the subgrade shall be finished with a smooth steel wheel roller weighing not less than 10 tons. Finished surface of the subgrade shall be within a tolerance of 0.04 feet at every point.
6. Conduits, pipes, culverts and underdrains shall be neither disturbed nor damaged by proofrolling operations. Rollers shall neither pass

over, nor approach closer than 5 feet of conduits, pipes, culverts and underdrains unless the tops of those facilities are deeper than 3 feet.

### 3.12 PIPE BEDDING

- A. The contractor shall excavate to a minimum of 8-inch below the bells or couplings for the full width of the trench and shall place a minimum of 8-inches of No. 57 crushed stone bedding upon which the pipe is to be laid. In cases as determined by the Engineer, where trench material is suitable for use as bedding, the trench may be excavated to a point above the invert grade, and the trench bottom handshaped so that the bottom segment of the pipe is firmly supported on undisturbed material.
- B. Gravity Sewers and Accessories: Lay all pipes with minimum Type 5 – Class B or C bedding unless shown or specified otherwise. Excavate the bottom of the trench flat at a minimum depth as shown on the Drawings, below the bottom of the pipe barrel. Place and compact bedding material to the proper grade before installing the pipe. After pipe has been brought to the proper grade, haunching material shall be carefully placed by hand and compacted to the top of the pipe.
- C. Manholes: Excavate to a minimum of 12-inch below the planned elevation of the base of the manhole. Place and compact crushed stone bedding material to the required grade before constructing the manhole.
- D. At pipe subgrade, if foundation soil in trench is soft, wet, spongy, and unstable or does not afford solid foundation for pipe, the Contractor shall excavate as instructed by Engineer and provide stable base for placement of pipe bedding. Quantities of in-place crushed rock bedding which are in excess to those required on Drawings will be paid on basis of Unit Prices listed in Bid Form.
- E. Where rock has been excavated in the trench, the Contractor shall construct a base by placing crushed rock upon which a subgrade can be prepared. Crushed rock bedding in excess to that shown on Drawings will be paid for on basis of Unit Prices listed in Bid Form.
- F. Before any pipe is lowered in place, the trench bottom or bedding shall be prepared so that each pipe will have a firm and uniform bearing over the entire length of the barrel and a width equal to one-half the outside diameter of the pipe. All adjustments in line and grade shall be made by scraping away or filling and tamping in under the barrel of the pipe. Wedging and/or blocking are not permitted.

### 3.13 PIPE AND UTILITY TRENCH BACKFILL

- A. Pipe Zone Backfill:



1. The pipe zone is defined as that portion of the vertical trench cross-section lying between a plane below the bottom surface of the pipe and a plane at a point above the top surface of the pipe. The bedding is defined as that portion of pipe zone, backfill material between the trench subgrade and the bottom of the pipe. The embedment is defined as that portion of the pipe zone backfill material between the bottom of the bedding and a level line of initial backfill (12" above the top of pipe).
2. After compacting the bedding, the Contractor shall perform a final trim using a stringline for establishing grade, such that each pipe section when first laid will be continually in contact with the bedding along the extreme bottom of the pipe. Excavation for pipe bells and welding shall be made as required.
3. The pipe zone shall be backfilled with the indicated backfill material. The Contractor shall exercise care to prevent damage to the pipeline coating, cathodic bonds, and the pipe itself during the installation and backfill operations.
4. If a moveable trench shield is used during backfill operations, the shield shall be lifted to a location above each layer of backfill material prior to compaction of the layer. The Contractor shall not displace the pipe or backfill while the shield is being moved.
5. Selected backfill material for the pipe zone shall consist of specified material herein or native or imported granular material as approved by Engineer in advance of placement. Place material in the trench simultaneously on each side of the pipe for the full width of the trench and the depth of the pipe zone in layers 6-inches in depth. Each layer shall be thoroughly compacted by mechanically tamping or vibrating. In all cases, backfilling of the pipe zone must be done by hand. Particular attention shall be given to underside of the pipe and fittings to provide a firm support along the full length of the pipe. The pipe zone shall be considered to extend 12-inches above the top of the pipe, and shall be compacted to a compaction of not less than 95 percent of maximum dry density at optimum moisture content as herein after specified. Care shall be taken not to damage pipe or special coatings on the pipe.

**B. Trench Zone Backfill:**

After the pipe zone backfills have been placed, backfilling of the trench zone may proceed. The trench zone is defined as that portion of the vertical trench cross-section lying as indicated between a plane above the top surface of the pipe and a plane at a point 18 inches below the finished surface grade, or if the trench is under pavement, 18 inches below the

roadway subgrade. If flooding, ponding, or jetting is used, the pipe shall be filled with water to prevent flotation.

- C. Backfilling Pipe Trench: After the pipe had been laid in the trench and has been inspected and approved, and backfilling in the pipe zone is complete and compacted, the remainder of the trench may be backfilled. The backfill material shall be suitable material as hereinbefore specified. Care shall be taken to insure that no voids remain under, around or near the pipes.
- D. Compaction: The maximum dry density and optimum moisture content of each soil type used in the controlled compacted fill shall be determined by ASTM D698 compaction method. Field density tests shall be determined in accordance with ASTM D1556. Testing shall be paid for separately by the City directly to the testing laboratory.
- E. Placement and Compaction of Trench Backfill: The placement and compaction of all trench backfill shall conform to one of the following methods, subject to the qualification specified therein:
1. Mechanically Compacted Backfill (Unpaved Areas):. With approval of Engineer, backfill shall be mechanically compacted by means of tamping rollers, sheepsfoot rollers, pneumatic tire rollers, vibrating rollers, or other mechanical tampers to a minimum of 95 percent at optimum moisture. Trench backfill compaction above the pipe zone shall be to a minimum 95 percent in areas under buildings and pavements. Where the backfill soil has had a clay-like behavior and has a plasticity index of at least 12, only the upper 3-feet of material placed will require minimum compaction of 95 percent. All such equipment shall be of size and type approved by the Engineer. Impact-type pavement breakers (stompers) will not be permitted over any pipe. Permission to use specific compaction equipment shall not be construed as guaranteeing or implying that the use of such equipment will not result in damage to adjacent ground, existing improvements, or improvements installed under the Contract. The Contractor shall make its own determination in this regard. Mechanically compacted backfill shall be placed in horizontal layers not exceeding the maximum thickness of 8 inches. Each layer shall be evenly spread, the moisture content brought to near optimum condition and then tamped or rolled until the specified compaction and moisture content had been attained.
  2. Graded Aggregate Base (Paved Areas) – See Appendix F - Department of Public Works Public Right of Way Manual.
- F. Additional Material: Where final grades above the pre-construction grades are required to maintain minimum cover, additional fill material will be shown on the Drawings. Utilize excess material excavated from the trench, if the material is suitable. No additional payment will be made for additional

material when excavated materials are used. If excess excavated materials are not suitable, or if the quantity available is not sufficient, provide additional suitable fill material.

- G. Final Backfill: Final backfill is all backfill in the trench cross-sectional area within 18 inches of finished grade, or if the trench is under pavement, all backfill within 18 inches of the roadway subgrade.

### 3.14 BACKFILLING AROUND STRUCTURES

A. General:

1. Remove debris from excavations before backfilling.
2. Do not backfill against foundation walls until so instructed by the Engineer.
3. Wherever possible, backfilling shall be simultaneous on both sides of walls to equalize lateral pressures.
4. Do not backfill on only one (1) side of vertically spanning walls unless walls are adequately shored or permanent construction is in place to furnish lateral support on both top and bottom of wall.

### 3.15 FIELD TESTING

- A. General: All field soils testing will be done by a testing laboratory of the City's direction except as indicated below. Testing shall be paid for separately by the City.
- B. Where soil material is required to be compacted to a percentage of maximum density, the maximum density at optimum moisture content will be determined in accordance with Method C of ASTM D 698. Where cohesionless, free draining soil material is required to be compacted to a percentage of relative density, the calculation of relative density will be determined in accordance with ASTM D 4253 and D 4254. Field density in-place tests will be performed in accordance with ASTM D 1556 - Standard Test Method for Density and Unit Weight of Soil in Place by the Sand-Cone Method, ASTM D 2922 - Standard Test Methods for Density of Soil and Soil-Aggregate in Place by Nuclear Methods (Shallow Depth), or by such other means acceptable to the Engineer.
- C. In case the test of the fill or backfill show non-compliance with the required density, the Contractor shall accomplish such remedy as may be required to insure compliance. Subsequent testing to show compliance shall be by a testing laboratory selected by the City and paid by the Contractor.

- D. The Contractor shall provide test trenches and excavations including excavation, trench support, and groundwater removal for the City's field soils testing operations. The trenches and excavations shall be provided at the locations and to the depths required by the City.

### 3.16 GRADING

- A. General:
  - 1. Perform all rough and finish grading required to attain the elevations indicated on the Drawings.
  - 2. Perform rough grading to an accuracy of plus or minus 0.15 feet.
- B. Grading Around Buildings: Control the grading around buildings so the ground is pitched to prevent water from running into the excavated areas of a building or damaged other site features.
- C. Treatment After Completion of Grading:
  - 1. After grading is completed, permit no further excavation, filling or grading, except with the approval of the Engineer.
  - 2. Use all means necessary to prevent the erosion of freshly graded areas during construction and until such time as permanent drainage and erosion control measures have been installed.

### 3.17 EXCESS WATER CONTROL

- A. Regulations and Permits: Obtain all necessary soil erosion control permits in accordance with the Georgia Soil Erosion and Sedimentation Control Act, and all pertinent rules, laws, and regulations.
- B. Unfavorable Weather:
  - 1. Do not place, spread, or roll any fill material during unfavorable weather conditions.
  - 2. Do not resume operations until moisture content and fill density are satisfactory to the Engineer.
  - 3. Any inundated area that freezes shall be removed and refilled at no additional cost to the City.
- C. Provide berms or channels to prevent flooding of subgrade. Promptly remove all water collected in depression.

D. Pumping, Drainage and Dewatering:

1. Provide, maintain and use at all times during construction adequate means and devices to promptly remove and dispose of all water from every source entering the excavations or other parts of the Work
2. Dewater by means that will insure dry excavations, preserve final lines and grades, and do not disturb or displace adjacent soil.
3. All pumping and drainage shall be done with no damage to property or structures and without interference with the rights of the public, owners of private property, pedestrians, vehicular traffic or the work of other contractors, and in accordance with all pertinent laws, ordinances, and regulations.
4. Do not overload or obstruct existing drainage facilities.

**3.18 SETTLEMENT**

- A. The Contractor shall be responsible for all settlement of backfill, fills, and embankments, which may occur within one (1) year after final acceptance of the Work by the City.
- B. The Contractor shall make, or cause to be made, all repairs, or replacements made necessary by settlement within thirty (30) days after receipt of written notice from the Engineer.

**3.19 CLEANING**

- A. Upon completion of the Work of this Section, remove all rubbish, trash, and debris resulting from construction operations. Remove surplus equipment and tools. Leave the site in a neat and orderly condition acceptable to the engineer, and in conformance with the General Conditions of the Contract Documents.

END OF SECTION

(This page is intentionally blank)

---

**SECTION 02224****JACK AND BORE OR TUNNEL INSTALLATION****PART 1 GENERAL****1.01 SCOPE**

- A. The work covered by this Section includes furnishing all labor, materials, equipment and incidentals required to jack and bore a casing or construct a tunnel and to complete pipeline construction as described herein and as shown on the Drawings.
- B. The Contractor has the option to use either excavation method (i.e, jack and bore a casing or construct a tunnel) to complete the crossings as shown on the Drawings.
- C. Supply all materials and perform all work in accordance with applicable American Society for Testing and Materials (ASTM), American Water Works Association (AWWA), American National Standards Institute (ANSI) or other recognized standards. Latest revisions of all standards are applicable. If requested by the Engineer, submit evidence that manufacturer has consistently produced products of satisfactory quality and performance over a period of at least two years.

**1.02 QUALITY ASSURANCE**

- A. Reference Standards: The Contractor shall comply with the applicable provisions and recommendations of the latest editions of the following standards, except as otherwise shown on the Drawings or specified herein.
  - 1. AASHTO M190 – Standard Specification for Bituminous Coated Corrugated Metal Culvert Pipe and Pipe Arches
  - 2. ASTM A36 – Standard Specification for Carbon Structural Steel
  - 3. ASTM A123 – Standard Specification for Zinc (Hot-Dip Galvanized) Coatings on Iron and Steel Products
  - 4. ASTM A153 – Standard Specification for Zinc Coating (Hot-Dip) on Iron and Steel Hardware
  - 5. ASTM A307 – Standard Specification for Carbon Steel Bolts and Studs, 60,000 psi Tensile Strength

6. ASTM A1011 – Standard Specification for Steel, Sheet and Strip, Hot-Rolled Carbon, Structural, High-Strength, Low-Alloy, High-Strength Low-Alloy with Improved Formability and Ultra-High Strength.

### 1.03 SUBMITTALS

- A. Submittals shall be made in accordance with the requirements of the General Conditions of the Contract Documents. In addition, the following specific information shall be provided:
  - B. Method Submittals: The Contractor shall provide for the Engineer's approval, detailed plans for the methods proposed for the installation of the casing or construction of the tunnel. These plans shall address the following:
    1. Groundwater Control: The Contractor shall control groundwater throughout the installation of the casing or construction of the tunnel. The groundwater shall be controlled by dewatering (well points, sumps, or deep wells), grouting, freezing or other methods approved by the Engineer. The Contractor shall prepare a written, detailed plan for controlling the groundwater, citing similar installation conditions and results. This plan shall be submitted to the Engineer prior to any construction for the casing or tunnel.
    2. Face Protection: The face of the excavation shall be protected from the collapse of the soil into the casing or tunnel.
    3. Pit Design: The design of the jacking and receiving pits and required bearing to resist the jacking force is the responsibility of the Contractor. The Contractor shall engage the services of a professional engineer with current registration in the State of Georgia to design all cofferdam and sheeting and bracing systems for the jacking and receiving pits. The Contractor's Engineer shall submit to the Engineer a signed statement that he has been employed by the Contractor to design the cofferdam and sheeting and bracing systems.
    4. Submit additional working drawings, written procedures and calculations describing in detail the proposed jack and bore or tunneling method and the entire operation. Additional submittals shall include, but not be limited to, ground stabilization if proposed, excavation procedures, control of casing alignment and grade, support of face, detection of surface movement, procedure for installing pipes and anchors and placement of grout between the pipe and the casing and in the annular space around the tunnel. If, in opinion of the Contractor, modifications to the methods are required during construction, working drawings shall be submitted delineating such modifications, including reasons for the modifications.



- C. Material Submittals: The Contractor shall provide for the Engineer's approval, shop drawings, proposed construction drawings and other pertinent specifications and product data as follows:
  - 1. Shop drawings for casing pipe and tunnel liner plate showing sizes and connection details.
  - 2. Design mixes for concrete and grout.
  - 3. Casing Spacers.
- D. Experience Submittals: Jacking and boring casings and tunnel construction are deemed to be specialty contractor work. If the Contractor elects to perform the work, the Contractor shall provide evidence of experience as required by the General Conditions. A minimum of five continuous years of experience in installation of steel casings and tunnel construction is required of the Contractor proposed to do the work. Evidence of this experience shall be provided with the shop drawings for review by the Engineer.

#### **1.04 STORAGE AND PROTECTION**

- A. All materials shall be stored and protected in accordance with the manufacturer's recommendations and as approved by the Engineer.

#### **1.05 PROJECT PERMITS**

- A. The City has obtained permits as specified in Section 01060 of these specifications. The Contractor's attention is directed to the requirements and conditions contained in the permits. All costs imposed by the Georgia Department of Transportation or the railroad or other agencies as a requirement for the Contractor to complete the required scope of work will be paid for by the Contractor.

### **PART 2 PRODUCTS**

#### **2.01 MATERIALS AND CONSTRUCTION**

- A. Casing
  - 1. The casing shall be new pipe made from steel plate having minimum yield strength of 35,000 psi. The steel plate shall also meet the chemical requirements of ASTM A36.
  - 2. The outside of the casing pipe shall be coated with coal tar epoxy having a minimum dry film thickness of 16 mils. Surface preparation shall be SSPC-SP-10. Epoxy shall have a minimum solids content of 65 percent by volume and shall be air or airless spray applied. The minimum drying

time for the epoxy shall be seven days. Brushing shall be permitted in small areas only. All coating and recoating shall be done in strict accordance with the manufacturer's recommendations. Epoxy shall be Tnemec, Kop-Coat or Valspar.

3. The thicknesses of casings shown in the following table are minimum thicknesses. The actual thicknesses shall be determined by the casing installer, based on an evaluation of the required forces to be exerted on the casing when jacking. Any buckling of the casing due to jacking forces shall be repaired at no additional cost to the City.
4. The diameters of the casings shown in the following table and shown on the Drawings are minimum diameters. Larger casings, with the Engineer's approval, may be provided at no additional cost to the City, for whatever reasons the Contractor may decide, whether due to casing size availability, line and grade tolerances, soil conditions, etc.

B. Casing Sizes

1. Under Railroads:

Pipe Diameter, Inches	Casing Diameter, Inches	Wall Thickness, Inches (Uncoated)
6	14	0.282
8	18	0.313
10	20	0.344
12	22	0.375
14	24	0.407
16	30	0.469
18	30	0.469
20	32	0.501
24	36	0.532
30	42	0.563
36	48	0.688

42	54	0.813
48	60	0.876
54	66	1.000
60	72	1.125
64	76	1.125

2. Under Highways:

Pipe Diameter, Inches	Casing Diameter, Inches	Wall Thickness, Inches
6	12	0.250
8	16	0.250
10	16	0.250
12	18	0.250
14	22	0.250
16	24	0.250
18	30	0.312
20	30	0.312
24	36	0.375
30	42	0.375
36	48	0.500
42	56	0.500
48	60	0.500
54	66	0.750

60	72	0.750
64	78	1.000

C. Tunnel Liner

1. Tunnel liner plate shall consist of structural steel liner plates. Each section shall be composed of the number of plates required to produce a clearance around the pipe sufficient to install and properly joint the pipe. The liner plates shall be either 4-flange type or 2-flange lap-joint type.
2. Liner plates shall be fabricated from structural quality, hot-rolled carbon steel sheets or plates conforming to ASTM A1011.
3. Liner plates shall be galvanized in accordance with ASTM A123. All other hardware shall be hot dip galvanized in accordance with ASTM A153. Liner plates shall be bituminous coated in accordance with the requirements of AASHTO M190.
4. All liner plates shall be punched for bolting on both longitudinal and circumferential seams or joints and shall be so fabricated as to permit complete erection from inside the tunnel. All plates shall be of uniform fabrication and those intended for one size tunnel shall be interchangeable.
5. The plates shall be furnished with 2-inch diameter grout holes to facilitate grouting the annular space above and around the tunnel liner. All grout holes shall be equipped with screw type galvanized plugs for final watertight closure of the grout holes. Grout holes shall be spaced as shown on the Drawings.
6. Bolts and Nuts:
  - a. Bolt spacing shall be as specified by the plate manufacturer and shall be sufficient to develop the full strength of the plates.
  - b. Bolts and nuts used with the 2-flange plates shall be a minimum of 5/8-inch in diameter and shall conform to ASTM A307
  - c. Bolts and nuts used with 4-flange plates shall be not less than 1/2-inch in diameter for plate thicknesses up to and including 0.179-inches (7 gage) and not less than 5/8-inch in diameter for plates of greater thickness. The bolts and nuts shall be quick acting coarse thread and shall conform to ASTM A307.
  - d. Where required, bolts and nuts shall be hot dipped galvanized in accordance with ASTM A153.

D. Casing Spacers

1. Casing spacers shall meet one of the following requirements:
    - a. Casing spacers shall be flanged, bolt-on style with a two-section stainless steel shell lined with a PVC liner, minimum 0.09-inch thick also having a hardness of 85-90 durometer. Runners shall be attached to stainless steel risers which shall be properly welded to the shell. The height of the runners and risers shall be manufactured such that the pipe does not float within the casing. Casing spacers shall be manufactured by Cascade Waterworks Manufacturing Company, Advanced Products & Systems, Inc., or approved equal.
    - b. Casing spacers shall be a two-section, flanged, bolt on style constructed of heat fused PVC coated steel, minimum 14 gauge band and 10 gauge risers, with 2-inch wide fiberglass reinforced polyester insular duty PVC inner liner, minimum 0.09-inch thick, having a hardness of 85-90 durometer, and all stainless steel hardware. Casing spacer shall be manufactured by Pipeline Seal and Insulator, Ltd., or approved equal.
  2. Casing spacers shall be designed for the general configuration shown on the Drawings, including provisions for other conduits to be installed within the casing in addition to the carrier pipe.
- E. Grout: Grout shall be used for filling the void between the casing and the carrier pipe. Cement shall conform to ASTM C150, Type I or II. Grout shall have a minimum compressive strength of 100 psi attained within 24 hours.
- F. Carrier Pipe: Carrier pipes shall be as specified in Section 02665, Water Mains and Accessories; Section 02667, Large Water Transmission Mains and Section 02537, Ductile Iron Sanitary Sewer Pipe and Fittings. All joints of pipe in the casing shall be restrained.
- G. Surface Settlement Markers: Surface settlement markers within pavement areas shall be P.K. nails. Surface settlement markers within non-paved areas shall be wooden hubs.

## 2.02 EQUIPMENT

- A. Casings
1. A cutting head shall be attached to a continuous auger mounted inside the casing pipe.
  2. On casing pipe for water lines over 60 feet in length, the installation equipment shall include a steering head and a grade indicator.
  3. The steering head shall be controlled manually from the bore pit. The grade indicator shall consist of a water level attached to the casing which

will indicate the elevation of the front end of the casing or some other means for grade indication approved by the Engineer.

4. The steering head and grade indicator shall utilize a laser guidance system.

## B. Tunnels

### 1. Tunnel Boring Machine (TBM)

- a. The TBM shall be equipped with disc cutters of diameter 19 inches or greater designed for operation at thrusts of up to 70 kips per cutter.
- b. The TBM shall afford adequate protection against loss of ground and permit ground support adjacent to the tunnel face, as required by ground conditions.
- c. The TBM shall be equipped with a dust control system which includes a water spray system, dust shield and dust scrubber system.
- d. The method used to advance the TBM shall ensure its correct alignment at all times, without binding or imposing excessive loads on the primary tunnel supports or upon the surrounding ground.
- e. The TBM shall be equipped with a roll indicator and laser target system, which allows the operator to observe the machine's alignment and orientation (predictor system) from the control station.
- f. The TBM shall be grounded in accordance with the latest requirements of the National Electrical Code and equipped with ground fault protection.

### 2. Other Tunneling Equipment

- a. Power machinery and tools within the tunnel shall be operated by either electricity, compressed air, diesel with approved scrubber or other approved power. Electrical tools and equipment shall be grounded in accordance with the latest requirements of the National Electrical Code.
- b. All electrical equipment and power receptacles shall have appropriate ground fault protection.
- c. Provide temporary electrical lights to properly and safely illuminate all parts of the shafts and tunnel including special illumination at the working face. Lighting circuits shall be thoroughly insulated and separated from power circuits, and lights shall be enclosed in wire cages. Secure electrical permits required for completion of this work.

## PART 3 EXECUTION

### 3.01 GENERAL

- A. Interpretation of soil investigation reports and data, investigating the site and determination of the site soil conditions prior to bidding is the sole responsibility of the Contractor. Rock and/or water, if encountered, shall not entitle the Contractor to additional compensation.
- B. Boring and jacking casing and tunnel construction shall be performed so as not to interfere with, interrupt or endanger roadway surface and activity thereon, and minimize subsidence of the surface, structures and utilities above and in the vicinity of the work. Support the ground continuously in a manner that will prevent loss of ground and keep the perimeters and face of the casing, passages and shafts stable. The Contractor shall be responsible for all settlement resulting from operations and shall repair and restore damaged property to its original or better condition at no cost to the City.

### **3.02 GROUNDWATER CONTROL**

- A. The Contractor shall control the groundwater throughout the installation of the casing or construction of the tunnel.
- B. When water is encountered, provide and maintain a dewatering system of sufficient capacity to remove water on a 24-hour basis keeping excavations free of water until the backfill operation is in progress. Dewatering shall be performed in such a manner that removal of soil particles is held to a minimum. Dewater into a sediment trap and comply with requirements specified in Section 02125, Temporary and Permanent Erosion and Sedimentation Control.
- C. Methods of dewatering shall be at the option and responsibility of the Contractor. Maintain close observation to detect settlement or displacement of surface facilities due to dewatering. Should settlement or displacement be detected, notify the Engineer immediately and take such action as necessary to maintain safe conditions and prevent damage.

### **3.03 SAFETY**

- A. Provide all necessary bulkheads and shields to ensure complete safety to all traffic, persons and property at all times during the work. Perform the work in such a manner as to not permanently damage the roadbed or interfere with normal traffic over it in those areas immediately adjacent and outside the active project work area.
- B. Observe and comply with all applicable requirements of GDOT. Conduct the operations in such a manner that all work will be performed below the level of the roadbed.
- C. Perform all activities in accordance with the Occupational Safety and Health Act of 1970 (PL-91-596), as amended, applicable regulations of the Federal

Government, OSHA 29CFR 1926 and applicable criteria of ANSI A10.16-81, "Safety Requirements for Construction of Tunnel Shafts and Caissons".

### **3.04 HIGHWAY CROSSINGS**

- A. The Contractor shall be held responsible and accountable for the coordination and scheduling of all construction work within the highway right-of-way and the posting of all appropriate permits.
- B. Work along or across the highway right-of-way shall be subject to inspection by the highway department.
- C. All installations shall be performed to leave free flows in drainage ditches, pipes, culverts or other surface drainage facilities of the highway, street or its connections.
- D. No excavated material or equipment shall be placed on the pavement or shoulders of the roadway without the express approval of the highway department
- E. The Contractor will not be permitted to leave equipment (trucks, backhoes etc.) on the pavement or shoulder overnight. Construction materials to be installed, which are placed on the right-of-way in advance of construction, shall be placed in such a manner as not to interfere with the safe operation of the roadway.

### **3.05 RAILROAD CROSSINGS**

- A. The Contractor shall secure permission from the railroad to schedule work so as to not interfere with the operation of the railroad.
- B. Additional insurance is required for each railroad crossing. The Contractor shall furnish the railroad with such additional insurance as may be needed. The cost of such additional insurance shall be borne by the Contractor.
- C. All work on the railroad right-of-way, including necessary support of tracks, safety of operations and other standard and incidental operation procedures may be under the supervision of an authorized representative of the railroad and any decisions of this representative pertaining to construction and/or operations shall be final and construction must be governed by such decisions.
- D. If, in the opinion of the railroad, it becomes necessary to provide flagging protection or watchmen for the performance of any other work in order to keep the tracks safe for traffic, the Contractor shall coordinate such work and shall reimburse the railroad for such services, in accordance with procedures agreed upon by the Contractor and the railroad before construction is started.



- E. No blasting shall be permitted within the railroad right-of-way.

### **3.06 SURFACE SETTLEMENT MONITORING**

- A. Provide surface settlement markers, placed as specified and as directed by the Engineer. The Contractor shall place settlement markers outside of pavement area, along the centerline of the casing or tunnel at 20 foot intervals. Markers shall also be placed at each shoulder of the roadway, at each edge of pavement, at the centerline of the pavement and at 10 and 25 feet offset in each direction from the centerline of the casing. Tie settlement markers to bench marks and indices sufficiently removed as not to be affected by the Contractor's operations.
- B. Make observations of surface settlement markers, placed as required herein, at intervals acceptable to the Engineer. In the event settlement or heave on any marker exceeds 1-inch, the Contractor shall immediately cease work and using a method approved by the Engineer, take immediate action to restore surface elevations to those existing prior to start of Contractor's operations.
- C. Take readings and permanently record surface elevations prior to start of dewatering operations and/or shaft excavation. The following schedule shall be used for obtaining and recording elevation readings: all settlement markers, once a week; all settlement markers within 50 feet of the casing or tunnel heading, at the beginning of each day; more frequently at the Engineer's direction if settlement is identified. Make all elevation measurements to the nearest 0.01 foot.
- D. The Contractor shall cooperate fully with jurisdictional personnel. Any settlement shall be corrected by, and at the expense of, the Contractor.
- E. Promptly report any settlement and horizontal movement immediately to the Engineer and take immediate remedial action, at no cost to the City.

### **3.07 JACKING AND BORING**

- A. Pit
  - 1. Conduct jacking and boring operations from a pit excavated at one end of the section to be bored. Where conditions and accessibility are suitable, place the jacking pit on the downstream end of the bore.
  - 2. The pit shall be rectangular and excavated to a width and length required for ample working space. If necessary, sheet and shore the pit properly on all sides. Pit sheeting shall be timber or steel piling of ample strength to safely withstand all structural loadings of whatever nature due to site and soil conditions. Keep pit dry during all operations. Perform pit dewatering operations as necessary.

3. The bottom of the pit shall be firm and unyielding to form an adequate foundation upon which to work. In the event the pit bottom is not stable, excavate to such additional depth as required and place a gravel sub-base or a concrete sub-base if directed by the Engineer due to soil conditions.

B. Jacking Rails and Frame

1. Set jacking rails to proper line and grade within the pit. Secure rails in place to prevent settlement or movement during operations. The jacking rails shall cradle and hold the casing pipe on true line and grade during the progress of installing the casing.
2. Place backing between the heels of jacking rails and the rear of the pit. The backing shall be adequate to withstand all jacking forces and loads.
3. The jacking frame shall be of adequate design for the requirements of the Project. Apply thrust to the end of the pipe in such a manner to impart a uniformly balanced load to the pipe barrel without damaging the joint ends of the pipe.

C. Jacking and boring of casing pipes shall be accomplished by the dry auger boring method without jetting, sluicing or wet boring.

D. Auger the hole and jack the casing through the soil simultaneously.

E. Bored installations shall have a bored-hole diameter essentially the same as the outside diameter of the casing pipe to be installed.

F. Execute boring ahead of the casing pipe with care, commensurate with the rate of casing pipe penetration. Boring may proceed slightly in advance of the penetrating pipe and shall be made in such a manner to prevent any voids in the earth around the outside perimeter of the pipe. Make all investigations and determine if the soil conditions are such as to require the use of a shield.

G. As the casing is installed, check the horizontal and vertical alignment frequently. Make corrections prior to continuing operation.

H. Any casing pipe damaged in jacking operations shall be repaired, if approved by the Engineer, or removed and replaced at Contractor's own expense.

I. Lengths of casing pipe, as long as practical, shall be used except as restricted otherwise. Joints between sections shall be completely welded in accordance with AWS recommended procedures. Prior to welding the joints, the Contractor shall ensure that both ends of the casing sections being welded are square.

- J. The Contractor shall prepare a contingency plan which will allow the use of a casing lubricant, such as bentonite, in the event excessive frictional forces jeopardize the successful completion of the casing installation.
- K. Once the jacking procedure has begun, it should be continued without stopping until completed, subject to weather and conditions beyond the control of the Contractor.
- L. Care shall be taken to ensure that casing pipe installed by boring and jacking method will be at the proper alignment and grade.
- M. The Contractor shall maintain and operate pumps and other necessary drainage system equipment to keep work dewatered at all times.
- N. The carrier pipe shall be installed to the line and grade required within the casing and after placed and approved by the Engineer, the space between the outside of the carrier pipe and the casing shall be completely filled with grout pumped in a continuous operation in a manner to prevent the occurrence of any voids between the carrier pipe and the casing.
- O. Adequate sheeting, shoring and bracing for embankments, operating pits and other appurtenances shall be placed and maintained to ensure that work proceeds safely and expeditiously. Upon completion of the required work, sheeting, shoring and bracing shall be left in place, cut off or removed, as directed by the Engineer.
- P. Refer to Section 02225, Trench Excavation and Backfill for additional information related to trench excavation, all classes and types of excavation, the removal of rock, muck and debris, and the excavation of all working pits and backfill.
- Q. All surplus material shall be removed from the right-of-way and the excavation backfilled and compacted flush with the surrounding ground.
- R. Grout backfill shall be used for unused holes or abandoned pipes.
- S. Any replacement of carrier pipe in an existing casing shall be considered a new installation, subject to the applicable requirements of these specifications

### **3.08 FREE BORE**

- A. Where the Drawings indicate a pipeline is to be installed by boring without a casing, the Contractor shall construct the crossing by the free bore method. The free bore method shall be accomplished by the dry auger method. The free bore method shall be accomplished by the dry auger boring method without jetting, sluicing or wet boring.

- B. The diameter of the free bore shall not exceed the pipe bell outside diameter or the pipe barrel outside diameter plus 1-inch, whichever is greater.
- C. Free boring, where indicated on the Drawings, shall be performed at the Contractor's option. The Contractor may choose to construct the crossing by the conventional jack and bore casing method. If the Contractor chooses this method, it will be at no additional cost to the City.
- D. The Contractor will be responsible for any settlement of the roadway caused by the free bore construction activities.

### **3.09 TUNNELS**

#### **A. Shaft Excavation**

1. Excavate in such a manner that over break is held to a minimum. In soil and mixed face conditions, install primary support in continuous and close contact with the excavated surface to control water inflow and prevent ground loss, so that adjacent structures are not affected by ground movements. Excavation in soil shall not be advanced ahead of the previously installed primary support any more than is necessary for the installation of the succeeding section of primary support.
2. Whenever shaft sinking is suspended, complete primary support to the excavated surfaces and keep any dewatering system operating. The Contractor shall have qualified personnel periodically check conditions that might threaten the excavation stability.
3. Remove excavated soil and rock from the site and dispose of properly at a location secured by the Contractor.
4. Remove sheeting used for shoring from the shaft and off the job site. The removal of sheeting, shoring and bracing shall be done in such a manner as not to endanger or damage either new or existing structures, private or public properties and also to avoid cave-ins or sliding in the banks.

#### **B. Tunnel Excavation**

1. Excavate in such a manner that over break is held to a minimum.
2. Where water inflows in the tunnel face are large and increasing, the Engineer may instruct the Contractor to drill probe holes, relief holes and ground treatment holes in the tunnel face, and to carry out consolidation grouting before proceeding.

3. Whenever tunneling is suspended, complete installation of the primary support for that excavation cycle. Have qualified personnel periodically check conditions that might threaten tunnel stability.
4. Remove excavated rock from the excavation of the TBM erection, transit and reception chambers and dispose of properly at a location secured by the Contractor.

C. Liner Installation

1. The liner plates shall be installed progressively as excavation proceeds. Excavation shall not continue more than 24 inches past the end of the liner plate already in place. At this time an additional section of liner shall be installed before excavation shall continue.
2. Grout shall be placed under pressure in the annular space outside the tunnel as the excavation proceeds. Grout should be continuously placed as close to the heading as possible, using grout stops if necessary. Grout shall be injected in the lower holes first, moving upward as the annular space is filled. Screw type plugs shall be installed after filling each grout hole.

**3.10 VENTILATION AND AIR QUALITY**

- A. Provide, operate and maintain for the duration of project, a ventilation system to meet safety and OSHA requirements.

**3.11 ROCK EXCAVATION IN CASING**

- A. In the event that rock is encountered during the installation of the casing pipe which, in the opinion of the Engineer, cannot be removed through the casing, the Engineer may authorize the Contractor to complete the crossing with a tunnel.
- B. At the Contractor's option, the Contractor may continue to install the casing and remove the rock through the casing at no additional cost to the City.

**3.12 INSTALLATION OF PIPE IN CASING**

- A. After installation of the casing is complete, and has been accepted by the Engineer, install the pipeline in accordance with the Drawings and Specifications.
- B. Check the alignment and grade of the casing and submit a plan to the Engineer for approval to set the pipe at proper alignment, grade and elevation, without any sags or high spots.

- C. The carrier pipe shall be held in the casing by the use of casing spacers. The casing spacers shall be designed by the Contractor such that the pipe can be installed in the casing. Provide a minimum of two casing spacers per length of pipe, unless directed otherwise by the Engineer.
- D. Close the ends of the casing with 4-inch brick walls, plastered with portland cement mortar and waterproofed with asphaltic roofing cement.

### **3.13 INSTALLATION OF PIPE IN TUNNEL**

- A. After the tunnel is complete and has been accepted by the Engineer, install the pipeline in accordance with the Drawings and Specifications
- B. Check the alignment and grade of the tunnel and submit a plan to the Engineer for approval to set the pipe at proper alignment, grade and elevation, without any sags or high spots.
- C. Care shall be taken to prevent damage to the flanges of the tunnel liner plates.
- D. The Contractor shall be responsible for all bad joints including joints disturbed by placing the pipe in the tunnel.
- E. 3000 psi concrete as specified in Section 03300 shall used for constructing the tunnel invert.
- F. A method approved by the Engineer shall be used to support the pipe so that the weight of the pipe is not resting on the pipe bells
- G. Close the ends of the tunnel with 4-inch brick walls, plastered with portland cement mortar and waterproofed with asphaltic roofing cement.

### **3.14 SHEETING REMOVAL**

- A. Remove sheeting used for shoring from the shaft and off the job site. The removal of sheeting, shoring and bracing shall be done in such a manner as not to endanger or damage either new or existing structures, private or public properties and also to avoid cave-ins or sliding in the banks.

### **3.15 INTERSTATE RESTORATION**

- A. When boring and jacking or tunneling operations encroach upon the right of way of the federal interstate system, the Contractor shall restore all screening trees with seedlings of like species.

### **3.16 CLEANUP**

- A. Backfill materials shall be as specified in Section 02225. The site shall then be restored to its original condition or better.

**+ + + END OF SECTION 02224 + + +**

---

**SECTION 02270****Vegetative Erosion Control and Bank Stabilization****PART 1 – GENERAL****1.01 SCOPE**

- A. The Contractor shall provide erosion control and streambank stabilization including but not limited to fertilizing, seeding, planting, mulching, installation of erosion control fabric, guarantee and maintenance for all disturbed areas shown on the Contract Drawings and in accordance with this specification.

**1.02 REFERENCED SPECIFICATIONS, CODES, AND STANDARDS**

- A. This section is related to the following specification sections.
1. SECTION 02125: Erosion and Sediment Control
  2. SECTION 02273: Riprap
- B. This section references the following commercial standards:
1. “Manual for Erosion Control in Georgia”, published by the Georgia Soil and Water Conservation Commission (4310 Lexington Road, Athens, Georgia 30603), which is available on the Internet as a free download at <http://www.gaswcc.org>.
  2. “Guidelines for Streambank Restoration”, published by the Georgia Soil and Water Conservation Commission (4310 Lexington Road, Athens, Georgia 30603) in cooperation with Metro Atlanta Association of Conservation Districts, USDA Soil Conservation Service (now Natural Resources Conservation Service or NRCS), and the Georgia Environmental Protection Division.

**1.03 CONTRACTOR SUBMITTALS**

- A. General: Submittals shall be furnished in accordance with Section GC-28 – Working Drawings, Shop Drawings, Data on Material and Equipment, Samples and Licenses.
- B. Product Information:
1. Manufacturer’s product information for erosion control fabrics, geotextile fabrics (natural and synthetic fiber) and cellular confinement systems must be provided to the Engineer for written approval, prior to installation on any project site.



2. Information regarding the composition, infiltration rate, and chemical analysis of soil amendments including, but not limited to, fertilizer (natural and synthetic), agricultural lime, plant material compost, leaf or straw mulch, and peat moss must be provided to the Engineer for written approval prior to installation on any project site.
3. Information regarding the species mix and germination rates of erosion control grass seed mixes must be provided to the Engineer for written approval prior to installation on any project site.

C. Certificates:

1. Supplier or manufacturer's certificates, stating the source, quantity, and type of material, shall accompany each delivery. All certificates shall be submitted to the Engineer at the time of delivery. No materials or products shall be left at the project site without first notifying the Engineer.
2. Certificates of inspection of commercial plant material, as may be required by Federal, state, local, or other authorities having jurisdiction, must accompany the plant material shipment and must be submitted to the Engineer at the time of delivery.

D. Samples:

1. Grass seed: two-pound samples of each type of grass seed must be submitted to the Engineer for approval before the bulk grass seed is delivered to the project site. The samples shall be accompanied by a supplier's or dealer's germination rate and percentage of weed seed certifications. The Contractor shall plant the grass seed in test plots designated by the Engineer and analyze the plots for germination rates and weed content. Grass seed shall not be delivered to the project site without written approval from the Engineer. Approval of the seed samples by the Engineer shall not affect the right of the Engineer or Owner to reject the seed upon or after delivery.

E. Reports:

1. Soil Fertility Test: Independent laboratory test results for pH, organic material, texture, soluble salts, nitrogen, phosphorus, potassium, iron and micro-nutrients.
2. Soil Percolation Test: Independent laboratory test results for on-site soil percolation rates defining the infiltration rate through the top 8-

inches of soil. Information to be used to assist in determining irrigation requirements.

#### **1.04 SITE DISTURBANCE MINIMIZATION AND EROSION HAZARD REDUCTION**

- A. The Contractor shall be responsible for minimizing the amount of disturbed area on the site during construction. To accomplish this task the Contractor shall:
1. Install required temporary erosion control measures, as specified on the Contract Drawings prior to initiating any ground disturbing activities within the project site. The Contractor shall notify the Engineer when all temporary erosion control measures have been installed. The Engineer shall, within 24 hours following such notification, inspect all temporary erosion control measures installed by the Contractor. Following inspection the Engineer will notify the Contractor, in writing, that the installation of the temporary erosion control measures meets the Contract requirements and authorize the Contractor to proceed with ground-disturbing activities.
  2. Limit site access to the approved site access locations shown on the Contract Drawings unless otherwise authorized in writing by the Engineer.
  3. Limit the amount of exposed soils, in areas where vegetation removal is required, to the smallest practical area and for the shortest practical time period. See 1.04.B below.
  4. Extract, salvage and store all woody vegetation that has to be removed during construction but which can be replanted following the completion of construction. Salvaged plant material shall be stored in a temporary nursery. The property Owner, in conjunction with the Engineer, shall designate the approved location of the temporary nursery area prior to the initiation of plant salvage activities. The Engineer will review and approve the Contractor's plant salvage methods prior to the initiation of plant salvage activities. The Contractor shall provide temporary irrigation as necessary to maintain healthy plants based on site and climate conditions at the temporary nursery location.
  5. Salvage and stockpile onsite soils removed during clearing and grading activities and designated as suitable for reuse within the project site. All salvaged soil shall be covered with erosion control fabric or plastic to prevent wind or rainfall induced erosion. Protective covering shall be anchored around the edges of the

stockpile area using sandbags or other anchoring systems as approved by the Engineer.

6. Protect all vegetation within the project site that has not been specifically identified for removal or that is outside of any areas designated for clearing, grading, or construction activities. Vegetation to be preserved shall be identified and clearly marked using florescent pink or florescent orange flagging (attached to each plant) prior to initiation of clearing, grading, or construction activities.
  - a. Vegetation to be preserved shall include all existing vegetation vital to streambank stabilization that is not within a designated clearing, grading, or construction area.
  - b. Any vegetation providing food and/or critical habitat for any species listed as rare, threatened, or endangered by any Federal or state agencies shall be preserved. Such vegetation shall not be located within any areas of the project site designated for clearing, grading, or construction activities.
  - c. All vegetation within the delineated boundaries of jurisdictional or regulated wetland areas shall be preserved unless otherwise directed by the Engineer or as identified on the Contract Drawings. Any impacts to vegetation within delineated wetland area caused by or related to clearing, grading, or construction related activities within the project site shall be mitigated in accordance with applicable Federal, state, and/or local regulations. The Contractor shall be responsible for insuring that any Federal, state, or local permits required to alter delineated jurisdictional or regulated wetlands have been acquired and are included as part of the Contract Documents.
7. The Contractor shall establish all clearing limits within the project site in accordance with Contract Documents. Clearing limits shall be delineated in the field using “Hi-Vis Barrier Fencing” (available through Forestry Suppliers, Inc., 205 West Rankin Street, Jackson, MS 39201) or authorized substitute.
  - a. The barrier fence shall be installed by attaching the fence material to 6-foot metal fence posts driven into the ground a minimum of 2 feet at 6-foot intervals along the edge of those areas within the site that are not designated for clearing, grading, or construction related activities. The barrier fence shall be attached to the fence posts using loops of No. 9 wire; three loops spaced equidistant along each fence post.

- b. The Contractor shall install barrier fence around all areas where existing vegetation is to be preserved or protected. Barrier fence is reusable and shall be removed after all construction-related activities within the project site have ceased or as directed by the Engineer.
- B. The Contractor shall notify the Engineer when ground-disturbing activities have ceased within an area of the site where all construction activities (excluding those activities inside of structures) has been completed. This notification shall occur within 24-hours following the completion of ground-disturbing activities. The Engineer shall inspect those areas and notify the Contractor, in writing, that the Contractor shall apply erosion control seed/mulch mixtures to reduce or eliminate erosion hazards within those disturbed areas. The Contractor shall, within 24-hours after receiving notification from the Engineer, apply erosion control seed/mulch mixes in accordance with the Contract Documents.

## 1.05 ACQUISITION OF PLANT MATERIALS

- A. The Contractor shall obtain all live plant materials (cuttings and whole plants) from local plant suppliers (nurseries, landscaping companies, plant collectors, etc.). All live plant material shall be from plant stocks grown within a 50-mile radius of the project site. Locally grown or harvested plant materials are generally better adapted to local growing conditions and tend to be more resistant to plant diseases and climatic variations than plants grown or plant materials harvested from outside the local area of the project.
  1. If the Contractor is unable to obtain the specified plant materials from the local area the Contractor shall notify the Engineer in writing regarding the inability to obtain specified plant material. The Engineer shall notify the Contractor in writing regarding authorized plant material substitutions or alternative sources.
- B. The Contractor shall abide by all Federal, state, and local regulations regarding the collection of plant materials. The Contractor shall be responsible for obtaining all required collection permits (or shall insure that the Contractor's plant material supplier has obtained all required collection permits) from any and all Federal, state, or local jurisdictions with permitting or regulatory authority regarding plant material collection.
  1. In addition to any and all Federal, state, and local permits or authorizations the Contractor shall insure that any plant materials collected on private property were obtained with written permission or authorization from the property owner.

- C. All plant materials (cuttings or whole plants) collected from natural (non-nursery) locations shall be collected during the time period when those plants are dormant. All whole plants collected from natural (non-nursery) settings shall be collected in such a manner as to protect the plant's root system from a distance 3 inches to 6 inches outside the drip line of the plant to the stem and to a depth equal to or slightly greater than the radius of the drip line. All whole plants collected from natural (non-nursery) settings shall have the excavated root ball wrapped in burlap (tied with twine) to protect the root system.

## **PART 2 – PRODUCTS**

### **2.01 FERTILIZER**

- A. The Contractor shall have the native soil, within the project site and in those areas where plant materials (cuttings or whole plants) will be installed, tested to determine if fertilizers need to be added to the soil to assure viable plant growth and survival. The addition of fertilizer to the soil will not be required except in those soils with test results indicating low soil fertility or low organic content.
- B. The Contractor shall ameliorate natural soils with low soil fertility values with commercial, chemical type fertilizer, which has a certified composition of 10 percent nitrogen, 10 percent available phosphoric acid, and 10 percent soluble potash (10-10-10). Any chemical fertilizers added to the native soils shall be of a type that conforms to all applicable Federal, state, and local laws and regulations. Fertilizer shall be applied at a rate of 500 to 700 pounds per acre. The Contractor shall supply the fertilizer in one of the following forms:
1. A dry free-flowing granular fertilizer, suitable for application by an agricultural or commercial grade fertilizer spreader.
  2. A soluble form that will permit complete suspension of insoluble particles in water, suitable for application by a power sprayer (or commercial hydro-seeder).
  3. A homogenous pellet, suitable for application through a "Ferti-Blast™" gun or other similar device.
  4. A tablet or other form of controlled release with a minimum one-year release period.
- C. The Contractor shall be responsible for assuring the application of fertilizers is consistent with Federal, state, and local laws and regulations particularly in those areas within 25 feet of open water or wetland ecosystems.

- D. The Contractor shall provide the fertilizer in the form specified by the Contract Documents or as directed in writing by the Engineer.
- E. The Contractor may, with written authorization from the Engineer, use natural, composted materials to elevate low soil fertility. The Contractor shall provide the Engineer with the results of soil fertility tests conducted to evaluate the fertility of the native soil/organic compost mixture.

## 2.02 LIME

- A. The Contractor shall apply agricultural lime to the native soils unless soil test results indicate that the addition of agricultural lime is unnecessary. The Contractor shall provide the Engineer with test results indicating the application of agricultural lime is unnecessary. Agricultural lime shall be of a standard manufacture, flour grade, meeting the requirements of ASTM C-602.

## 2.03 WHOLE LIVE PLANTS

- A. The following describes the types of whole live plants that may be required as a part of this contract.
  - 1. Seedlings: Plants grown from cuttings, seeds, or other approved propagation methods (i.e., air rooting). These plants do not normally show form characteristics of the species and are generally less than three years of age and less than 24 inches in height. Measurement for purposes of payment or design is in 3-inch height increments.
  - 2. Whips: Bareroot, broadleaf trees, generally unbranched and between 2 feet and 6 feet in height. Measurement for purposes of payment or design is in 1-foot height increments.
  - 3. Broadleaf Trees: Branched deciduous trees over 6-feet in height. Measurement for purposes of payment or design is by mainstem diameter or in 1-foot height increments.
  - 4. Coniferous Trees: Coniferous trees over 2 feet in height. Measurement for purposes of payment or design is in 1-foot height increments.
  - 5. Shrubs: Typically multi-stem or single-stemmed plants species that are less than 30 feet in height at maturity. Shrubs used in restoration projects are typically between 2-foot and 4-foot in height when delivered to a project site. Shrubs can be either delivered with a burlap wrapped root ball or in containers ranging from a 1-

gallon to 5-gallon size. Measurement for purposes of payment or design is typically by container size or in 1-foot height increments.

6. Groundcover Species: Typically low growing or prostrate plants delivered to a project site in 4-inch, 6-inch, 10-inch, or 1-gallon size nursery pots. The species can vary from woody to herbaceous plants. Measurement for purposes of payment or design is typically based on container size.

## 2.04 MULCH AND OTHER AMENDMENTS

- A. Bark or Wood Chip Mulch: Bark or Wood Chip Mulch shall be derived from pine or hemlock species. Local hardwood species can be used with authorization from the Engineer. The mulch shall be ground so that a minimum of 95 percent of the material by loose volume will pass through a 1.5-inch mesh screen (sieve) and no more than 55 percent of the material by loose volume will pass through a ¼-inch mesh screen (sieve). The mulch shall not contain any resin, tannin, or other compounds in quantities that would be detrimental to plant life, water quality or aquatic organisms.
- B. Wood Cellulose Fiber Mulch: Wood Cellulose Fiber Mulch shall be used, as part of the hydro-seeding application shall be a fibrous wood cellulose product produced and marketed specifically for use in hydro-seeding applications. Mulch shall be produced from natural or recycled wood fiber such as woodchips, mill wastes, logging slash, or recycled construction wastes.
  1. Mulch shall be free of any rock, plastic, metal, or other non-woody material.
  2. Mulch shall be treated with a non-toxic green dye that facilitates inspection and application. The dye must be certified to contain less than 250 ppm of boron and certified as non-toxic to both plants and animals.
  3. Mulch shall be manufactured in such a manner that after addition to water and agitation in slurry tanks the fibers stay uniformly suspended to form homogenous slurry.
  4. When hydraulically applied to the ground the mulch shall allow the absorption and percolation of water.
  5. Each package of mulch shall be tagged or marked to show dry weight and a certification of at least 93 percent organic content on an oven-dry basis as determined by ASTM 586.

6. The moisture content of the mulch shall be no greater than 15 percent as determined by oven-dried weight.

## **2.05 SEED**

- A. The Contractor shall supply specified seed mixes, which are certified a minimum of 95% pure with a germination rate of 80% or greater, to the project site in the supplier's original, unopened bags. The Contractor shall insure that a certification tag is attached to each bag that displays or clearly identifies:
  1. the scientific and common names of the seed,
  2. the species names of all grass, legume, or cover crop seed included in the mix,
  3. the lot number of the mix,
  4. the percentage of weed seed and inert material,
  5. the germination rate, and
  6. the purity percentage.

## **2.06 SOD**

- A. Sod shall contain a minimum of 85% perennial grass species adapted to average climatic conditions at the project site. Any proposed substitute grass seed mixes, available in the local market at the time sod is to be installed at the site, shall be submitted to the Engineer for review and approval.
  1. Sod shall be field grown for one calendar year or longer and have a well-developed root structure.
  2. Sod shall be free of thatch, weeds, undesirable plant species, nematodes, diseases, and insect damage.
  3. Sod shall be free of stones larger than 1-inch diameter, large chunks (>1 cubic inch in size) of woody material, and all human-made products such as plastic, glass, metal objects, and concrete.
  4. Prior to harvest the sod shall be green, in an active and vigorous state of growth, and mowed to a height not less than ¼-inch and no greater than 1-inch.



5. Sod shall be cut in rectangular pieces with straight edges. Any sod with torn ends or irregular edges shall be rejected by the Engineer.

## 2.07 TALL WOODEN STAKES

- A. These shall be untreated wooded stake or poles, preferably cedar, 5 feet to 8 feet in length, and either nominally 2-inch by 4-inch dimension lumber or 3-inch diameter poles.

## 2.08 TACKIFIER

- A. Tackifier used in hydro-seeding or mulching applications to hold the seed or mulch product to the soil or slope shall conform the following:
  1. Tackifier shall be derived from organic plant sources containing no growth or germination inhibiting materials.
  2. When combined with water the tackifier shall have the property of even dispersion and suspension and shall blend evenly in slurry (i.e. a water and wood cellulose fiber mix).
  3. Tackifier shall be mixed with a dyed wood cellulose fiber at a rate of 150 pounds of fiber per acre to monitor application rates and coverage.

## 2.09 EROSION CONTROL FABRICS/GEOSYNTHETICS

- A. Acceptable erosion control products include:
  1. Jute Matting Or Coconut Fiber (Coir) Matting - Natural fiber products that are woven into a fabric that is typically produced in widths ranging from 4 feet to 16 feet (or more) and delivered to the end user in rolls. These materials are generally rolled out over an area of disturbed soil to stabilize the soil, reduce splash erosion, and provide a seedbed for the erosion control seed mix. This product shall be anchored using nine-inch 2-legged wooden or metal staples or as otherwise specified by the product manufacturer.
    - a. Jute matting or coconut fiber matting shall be provided in rolls that are 4 feet (48 inches) wide and 50 yards (150 feet) with finished edges on the long sides.
    - b. The matting shall be a woven material made of twisted, unbleached “yarn” with a weave opening of ¼-inch to ¾-inch square.

- c. Selected materials used shall be consistent with the site conditions, anticipated runoff velocities, soil characteristics, and rainfall intensities. The Engineer prior to procurement and delivery to the site shall approve selected materials.
- d. All manufacturers' specifications shall be provided to the Engineer for approval.

2. Erosion Control Blanket

Manufactured product combining two layers of woven synthetic material with a layer of straw, coconut fiber, shredded bark, or wood fiber (excelsior) sandwiched between the synthetic fabric layers. This product is manufactured in rolls of varying widths and lengths and is available from a variety of manufacturers and suppliers. Acceptable manufacturers include Belton Industries, North American Green, and CSI Geosynthetics. Products vary in specification and shall be selected based on their applicability to the project site conditions. Product is anchored using nine-inch, 2-legged wooden or metal staples or as specified by the product manufacturer.

- a. Selected material used shall be consistent with the site conditions, anticipated runoff velocities, soil characteristics, and rainfall intensities.
- b. All manufacturers' product specifications shall be provided to the Engineer for approval.

3. Plastic (Polyethylene) Sheeting

This product is used to temporarily cover exposed soils to prevent erosion or to cover areas where seed has been applied but temperatures are below germination levels and surface erosion risk is moderate to high. This product is generally anchored with sandbags.

- a. Plastic sheeting shall be clear and a minimum thickness of 6 mils.
- b. Refer to Specification Section 02125 for additional specifications.

4. Cellular Confinement System

The cellular confinement system shall meet or exceed the following specifications:

- a. Expanded Dimension      8 feet x 20 feet
- b. Collapsed Dimension      11 feet 5 inches by 5 inches

- c. Panel Thickness (Nominal) 0.047 inches
- d. Panel Weight 57 pounds (deeper cells weigh more)
- e. Individual Cell Depth 4 inches (other depths available)
- f. Cell Area 38 square inches
- g. Cell Seam Node Pitch 13 inches
- h. Welds per Seam 3
- i. Seam Tensile Peel Strength 225 PSI
- j. Installation Temp. Range -16 degrees to 110 degrees F.
- k. Polymer Material HDPE (High Density Polyethylene)
- l. Color Black
- m. Carbon Black Content 2%
- n. Chemical Resistance Superior

## **2.10 WARRANTY**

- A. The manufacturer shall warranty that the products under this specification are free from defects in materials and workmanship. The manufacturer and/or supplier shall agree to replace all defective materials without charge. The manufacturer shall have the right to inspect all materials identified by the purchaser as defective to determine probable cause or defect prior to replacement. The supplier shall provide the Engineer with specification tags for a cellular confinement system products delivered to the project site.

## **PART 3 – EXECUTION**

### **3.01 GENERAL**

- A. Weather Conditions:
  - 1. The Contractor is responsible to monitor weather conditions and weather forecasts to ensure that no areas of exposed soil shall be developed unless the appropriate erosion control measures can be implemented within 12 hours prior to a predicted rain event.

2. No seeding, fertilizing, or mulching shall be done:
  - a. when wind velocity exceeds 4 mph
  - b. within 12 hours after rain
  - c. when ground is frozen
  - d. if compacted soils have not been scarified prior to application

B. Soil Preparation:

1. The ground to be seeded or planted shall be graded in conformance with the Contract Drawings unless otherwise directed by the Engineer.
2. The ground shall be scarified (loosened) to alleviate compaction and manipulated to remove large rocks (>3-inch diameter), roots or pieces of wood (>24 cubic inches) and all human-made materials exposed within the seeding, planting, sod installation, and/or erosion control fabric or cellular confinement system placement areas.
3. The Contractor may leave larger rocks and roots or pieces of woody debris if authorized by the Engineer or as shown on the Contract Drawings.

C. Grading and Shaping:

1. All slopes steeper than 4:1 shall be graded and shaped to promote plant establishment.
2. All areas where over-excavation is specified to allow incorporation of soil amendments, the Contractor shall notify the Engineer within 24 hours prior to final over-excavation grading and prior to the incorporation of any soil amendment products.
3. No soil amendment products shall be added to the native soil material until the Engineer approves the amendment.
4. Final grades shall be the elevation of the ground as shown on the Contract Documents after all soil amendments have been added.
5. The Contractor shall notify the Engineer within 48 hours prior to completion of final grading.

6. Final grading shall be inspected and approved by the Engineer. Unless otherwise authorized the Contractor shall not commence seeding, sod installation, erosion control fabric placement, installation of cellular confinement systems, or construction of bank stabilization measures until the final grading has been approved.

D. Soil Amendments:

1. Prior to seeding any areas the soil will be tested to determine the need for the addition of agricultural lime, organic compost, and/or fertilizers. The Engineer will collect the appropriate samples and submit those samples for testing. Results of the testing will be transmitted to the Contractor to allow determination of soil amendment needs.
2. Soil amendments such as fertilizer, lime, and mulch may be added separately as in the Dry Method described below (see Section 3.02) or incorporated into a water-based homogenous slurry that is applied by hydroseeding methods (see Section 3.03).
3. Soil amendments shall not be applied by water-based slurry on slopes steeper than 3:1.

### 3.02 DRY METHOD SEEDING

- A. Seeding: The Contractor shall notify the Engineer not less than 24 hours in advance of any seeding operation and shall not begin work until area prepared or designated for seeding have been approved. Following approval by the Engineer, seeding shall commence immediately. Seed shall be applied at the specified rate and with the seed mix specified in the Contract Documents. Dry seeding shall be conducted with one of the following procedures:
1. Use an approved blower system with an adjustable disseminating device capable of maintaining a constant measured rate of material discharge that will provide an even distribution of seed at the rate specified and in the area specified;
  2. An approved power-drawn drill or seeder capable of maintaining a constant measured rate of material discharge that will apply an even distribution of seed at the rate specified and in the area specified;
  3. A hand-operated seeder capable of maintaining a constant measured rate of material discharge that will an even distribution of seed at the rate specified and in the area specified; or

4. By hand broadcasting with frequent assessment of application rates. If hand applications are used the seed shall be incorporated into the upper ¼-inch of topsoil using rake or other method approved by the Engineer.

Any reseeding ordered by the Engineer and not considered to be the Contractor's responsibility shall be performed by the Contractor and Payment made at unit contract prices for the areas reseeded.

- B. Fertilizer: Fertilizer shall be applied in accordance with the procedures and requirements specified for seeding in Section 3.02.A. Fertilizer shall be placed at the rate and composition specified.

1. If specifications are not provided on the Contract Documents, fertilizer application rates and composition shall be determined by the results of a certified soil nutrient analysis.
  - a. The Contractor shall collect soil samples from within the project area and from stockpiles of soils imported to the site prior to initiating construction.
  - b. The Contractor shall submit the samples to a certified testing facility for soil nutrient analysis.
  - c. The Contractor shall forward the results of the soil nutrient tests along with recommended fertilization rates to the Engineer for review and approval.
2. Aerial or broadcast application of fertilizer application within 25 feet of the edge of an open, flowing or still, body of water or wetlands shall be prohibited.
3. Spot applications of fertilizer may be made, as necessary, within 25 feet of open water or using equipment other than aerial application equipment or blowers. Caution shall be exercised when applying fertilizer adjacent to a water body or wetland because of the risks of adversely impacting water quality (and aquatic organisms).

- C. Mulch Application: Specified mulch shall be spread evenly at the specified rates or 1,500 pounds over seeded areas within 24 hours after seeding unless otherwise directed by the Engineer.

1. Distribution of straw mulch shall be by means of an approved type mulch spreader, which utilizes forced air to blow mulch on seeded areas. In spreading straw mulch, the Contractor shall not use equipment that chops the straw into short (less than 6 inch) stalks.

2. In areas that are not accessible by mechanized mulching equipment, the Contractor shall mulch the area using hand methods approved by the Engineer.

### 3.03 HYDROSEEDING

A. Equipment: Hydroseeding is a method of applying a slurry-mixture that may contain grass seed (and/or the seeds of other native plants), fertilizer, wood cellulose fiber (dyed), tackifier, and water. The components of a hydroseed mix shall be mixed in tank (part of an approved hydroseeder) that uses water as a carrying agent and maintains continuous agitation and circulation through the use of internal mixing paddles (inside the mixing tank). The mixture shall be homogenous and dischargeable through a nozzle.

1. The approved hydroseeder shall have sufficient tank capacity to be able to cover ½-acre of seeding area per tank load.
2. The tank shall have a discharge system capable of discharging slurry at a continuous, uniform, specified application rate at a distance of 500 feet horizontally from and at an elevation difference of 150 feet vertically above the hydroseeder.
3. Discharge lines shall be large enough to prevent blockage as slurry passes through the lines.
4. The hydroseeder shall be equipped with discharge spray nozzles that will provide a uniform distribution of the specified slurry.
5. The Engineer shall inspect and authorize use of any hydroseeder delivered to the project site prior to the Contractor initiating any hydroseeding activity.

B. Mixture: The following mixture shall be used unless an alternate is approved by the Engineer:

1. Proportions per acre are:
  - a. 2,500 pound of wood cellulose fiber mulch,
  - b. 120 pounds of tackifier or soil stabilizer,
  - c. 60 pounds of fertilizer (or more if soil nutrient tests indicate a high nutrient need),
  - d. 3,000 gallons of water, and

- e. Grass seed, using the specified seed mix and application rates.
2. Preparation: As the mixture components are being placed in the tank the agitator should be running at a slow to medium speed to assure good blending of the materials and a complete homogenous mixture of the ingredients.
    - a. fill the tank 1/3 full of water,
    - b. add ½ of the total amount of tackifier or stabilizer needed,
    - c. add three 50 pound bales of wood cellulose fiber,
    - d. add ½ the total fertilizer required.
    - e. add enough water to bring the tank to half and increase the speed of the agitator to a fast speed.
    - f. add remaining 200 pounds of wood cellulose fiber when the tank is ¾-full.
    - g. add remaining tackifier and fertilizer.
    - h. add remaining water and begin immediately to apply slurry to areas designated for seeding.
- C. The grass seed to be used for this project shall be specified Contract Documents, in pertinent Special Provisions, or by the Engineer following consultation with a local agronomist or landscape architect.
    1. Application:
      - a. All of the slurry prepared must be applied within two hours following the start of mixture preparation.
      - b. Slurry shall not be applied if there is a forecast for rain within 3 days following application.

### 3.04 SOD PLACEMENT

- A. Sod Placement Period: Sod placement will be authorized by the Engineer after consultation with a local landscape architect or landscaping company to determine the earliest and latest start dates that will allow for a



reasonable chance of success when sod is installed. The installation may start as early as May 15<sup>th</sup> and should be completed prior to November 1<sup>st</sup> each year.

- B. Designated Sod Placement Areas: Sod shall be placed in areas as designated on the Contract Drawings or as directed by the Engineer.
- C. Sod Placement Procedures: The Contractor shall notify the Engineer a minimum of 48 hours prior to sod installation to allow an inspection of the prepared areas. The Contractor is responsible for insuring the sod placement area has smooth scarified soils, is properly graded, has an appropriate soil moisture prior to sod placement, and is free of larger rock (>2-inches diameter), woody debris, and human-made products.
1. On long steep slopes sod shall be laid perpendicular to the fall line of the slope.
  2. In ditches sod shall be laid at right angles to the flow line.
  3. When required, or as directed by the Engineer, sod sections placed on steep slopes shall be pinned using 2 anchoring pins on each side of the sod section.
  4. All air pockets shall be removed from under the sod by trampling or rolling with a compacting roller.
  5. Frayed ends of sod sections will be removed. Holes in sod area shall be patched with new, undamaged sod.
- D. Finishing: The Contractor shall insure the sod installation results in smooth parallel rows tightly packed together and in a relatively straight line. Sod sections shall be placed immediately adjacent to one another, as tightly packed together as possible. All joints shall be butted tightly together and staggered laterally. Sod sections shall not be stretched or reduced in size so they will fit.
- E. Watering: Irrigation may be required in sodded areas installed during the warmer, drier periods of the year. The Contractor shall have appropriate temporary irrigation equipment on site prior to starting the installation of sod. Irrigation of the sod shall commence at the end of the first day sod placement is initiated. Watering shall be provided at a rate of 1.5-inches per week (7 days). Watering shall, be the responsibility of the Contractor.

### 3.05 EROSION CONTROL PLAN IMPLEMENTATION

- A. Silt Fence Installation: Silt fence shall be installed as shown on the Contract Drawings, as described in the Temporary Erosion and Sediment

Control Plan (TESCP) or as directed by the Engineer. Silt fence shall be installed a minimum of 48 hours prior to the time the Contractor initiates construction activities (i.e. clearing, grubbing, and grading).

- B. Erosion Proofing Ingress/Egress Points: The Contractor shall place quarry spalls at all ingress/egress points on the site that are transitions for pavement to grassed or bare native soil. These transition areas will be 24 feet long and 12 feet wide. The Contractor shall place a geo-textile on the native soil prior to placing quarry spalls to prevent spalls from being pushed into the ground during wet site conditions.
- C. Application of Straw Mulch: See Section 3.02.C.
- D. Erosion Control Blankets:
1. Placement:
    - a. Biodegradable erosion control blanket shall be used on all slopes 4H:1V and steeper.
    - b. The erosion control blanket shall be spread only on prepared, fertilized and seeded surfaces.
    - c. On all slopes, the erosion control blanket shall be laid up-and-down the slope in the direction of water flow.
    - d. Waste of erosion control material shall be minimized by limiting overlaps as specified and by utilizing the full length of the netting at roll ends.
    - e. The erosion control blanket shall also be used on flatter areas where surface soil protection is considered critical to the establishment of vegetation and stabilization of erosive forces (i.e. water, wind, raveling, drying, etc.).
    - f. Proper selection of materials is critical for specific slopes and slope distances. No one product is applicable for all situations. The erosion control products should be selected on a case-by-case basis in consultation with the manufacturer.
  2. Anchoring Process:
    - a. Ends and sides of adjoining pieces of material shall be overlapped 6-inches and 4-inches respectively and stapled. Six anchors shall be installed across ends. A common row of staples shall be used at side joints. Staple through both blankets, placing staples approximately 6-inches apart.

- b. The top edge of the erosion control blanket shall be anchored in a 6-inch deep by 6-inch wide trench. Backfill and compact trench after stapling.
- c. Anchorage shall be by means of 9-inch long, two-legged staples driven vertically and full-length into the ground. The legs shall be spread 3 inches to 4 inches apart at the ground to improve resistance to pullout. In loose soils the use of 18-inch metal/washer pins may be required to properly anchor the blankets.
- d. All 3:1 or greater slopes shall be stapled with 2 staples per square yard in a triangular pattern. Staples shall be installed per the manufacturer's recommended staple pattern guide.
- e. The erosion control blanket shall not be stretched, but should be laid loosely over the ground to avoid the blanket being pulled downslope.
- f. The erosion control blanket shall not be rolled out onto ground containing frost within the 9-inch penetration zone of the anchorage staples. Further, no stapling shall be undertaken while any frost exists within the staple penetration zone.
- g. Refer to Specification Section 02125 – Erosion and Sedimentation Control for additional product requirements.

### 3.06 BANK STABILIZATION

#### A. Brush Mattress:

1. General Description: Brush mattress stabilization system is a combination of living material that forms a protective cover of vegetation over a relatively shallow slope (flatter than 2H to 1V gradient). The eroding surface shall be protected by placing layers of live branch cuttings directly on the slope with the basal ends of the cuttings located at or very near the toe of the slope and the growing tip oriented up the slope parallel to the fall line. Live stakes interspersed in the brush mattress shall be used as anchor points for tying a network of heavy duty landscaping twine to bind the brush mattress to the slope. In addition the toe of the treated slope shall be protected with either live or dead fascines anchored into the slope using stout stakes.

2. Construction Requirements:

- a. Preparation Time: Live branch cuttings shall be collected locally and within 5 days prior to planned installation. Live cuttings shall be stored in a cool, shaded area to avoid desiccation. Live stakes and live fascines (bundles of live branch cuttings) shall be prepared immediately (within 1 day – 24 hours) prior to installation.
- b. Planting Period: Plants shall be planted when willows or other suitable species used are dormant. This period extends from the time the leaves start to turn yellow in the autumn to the time new growth starts in the spring.
- c. Construction Sequence:
  - 1) Anchor the lower edge of the brush mattress in a trench, using a fascine to anchor and protect the lower bank edge from undermining.
  - 2) Place live branches on slope with butt ends pushed into soil below the mean high water level with growing tips placed at a slight angle in the direction of stream flow.
  - 3) Branches shall be placed to give coverage of approximately 4 branches every 6 linear inches.
  - 4) Pound wooden stakes to  $\frac{1}{2}$  their length into soil between branches 3-feet on center.
  - 5) Wrap wire or jute (heavy duty landscaping twine) around stakes and over branches as tightly as possible.
  - 6) Once the twine or wire has been placed and made as tight as possible by hand, pound wooden stakes further into the ground to tighten the wire or jute and compress branches to slope.
  - 7) Tamp live stakes between wooden stakes.
  - 8) After fascines and branches are installed, place soil on top slightly exposed material. Fill voids between the branches of the brush mattress with loose soil to promote rooting.]

**B. Branch Packing:**

3. General Description: Branch packing is a process of placing alternating layers of live cuttings and soil in a hole, gully, or slump area in a slope or streambank. Live cuttings shall be oriented so the growth end points out of the hole, gully, or slump area and the basal end is embedded into the native soil. The layers of live cuttings shall be placed at approximately a 20-degree to 30-degree angle above horizontal with the growth end higher in elevation than the basal end. In large hole, gully, or slump areas dormant posts or tall wooden stakes shall be installed vertically, within the area being stabilized, in a pattern designed to allow a network of heavy landscaping twine to be tied to the vertical posts and over the top of the last live branch layer to hold that layer in place. The last layer of live branch cuttings shall be covered with soil. In addition, the vertical posts or stakes add horizontal stability to the layers of live cuttings.
4. Construction Sequence:
  - a. Begin at the lowest point, drive stakes 3 to 4 feet vertically into the ground. Set the stakes 1 to 1.5 feet apart.
  - b. Place an initial layer of branches 4 to 6 inches thick at the bottom between the vertical stakes. Place additional branches in a crisscross pattern covering the entire surface of the layer. Add a layer of soil no thicker than 120 inches and compact it.
  - c. The thickness of the layer shall be determined by the steepness of the slope (thinner when steeper) and/or problems with bank seepage.
  - d. Growing tips of branches shall protrude slightly from the filled surface to retard velocity and filter sediment.
  - e. Growing tips of branches shall protrude slightly from the filled surface to retard flow velocity and filter sediment.
  - f. Install a relief drain at the rear of the trench and above the base flow level. Place outlet at or above flow level to protect against further slumping.
  - g. The final installation shall conform to the existing slope.

**B. Brush Layering:**

1. General Description:

- a. A layer of soil shall be wrapped in a coir fabric to form an approximately 12-inch thick “soft gabion” which shall be placed over the layer of live cuttings. More live cuttings shall be placed on top of the soft gabion and another soft gabion shall be placed on top of those cuttings and so on.
- b. Alternating layers of live cuttings and soft gabions shall be installed so the face of the gabions forms a slope ranging from 1H:1V to 3H:1V. The live cuttings shall protrude out of the soft gabion reinforced slope face approximately 2 to 3 feet.
- c. Brush layering/soft gabion systems over 7 feet in height and 20 feet in length shall have an Engineering analysis for completed determine slope stability prior to construction. The Contractor shall be consult with the Engineer prior to initiating construction of a vegetated soft gabion wall. The Contractor shall be responsible for collecting slope and soil stability information at slope or bank restoration sites where brush layering/soft gabion systems are proposed for installation.

2. Construction Sequence:

- a. The slope shall be prepared by excavating a native soil bench at the lowest elevation of the affected area. In the case of a streambank that is typically at the ordinary high water mark.
- b. The bench shall be constructed the full length of the effected area and shall be reinforced at the toe of the effected area using rock or dead plant cutting fascines to protect the toe from additional erosive forces. The bench shall be cut into the slope approximately 4 to 6 feet at a downward angle of approximately 5-degrees. The back slope of the treatment area is shall be cut at 0.5 to 1 or steeper.
- c. Soil excavated from the treatment area during the construction of the bench shall be stockpiled in an area designated by the Engineer. This soil shall be mixed with fertilizer and mulch.
- d. Live branch cuttings; shall be collected locally, brought to the project site, inspected and approved by the Engineer. Following acceptance by the Engineer, the Contractor shall

place the bundles of live cuttings in close proximity to the work area. The Contractor shall protect the cuttings from animal damage and desiccation.

- e. After excavation has been completed, the soil has been removed and the treatment area has been prepared and a layer of live cuttings shall be placed in the bottom of the cut bench and covered with native soil. The basal end of the cuttings shall be pushed into the soil at the vertical slope to provide contact with groundwater. The basal end of the cuttings shall be placed into the treatment area so they are oriented perpendicular to the slope face. The growth end of the cuttings shall protrude from the bank approximately 2 to 3 feet. There shall be 8 to 12 live cuttings per linear foot of bench in each brush layer.
- f. After the brush layer has been placed, roll out the coir fabric over the top of the live cuttings, insuring the selvage edge on one side of the roll is against the back slope of the cut-bench. Lay the remaining width of the material out so  $\frac{1}{2}$  the fabric width is laying flat and the other  $\frac{1}{2}$  is bunched up and laying on the live cuttings outside of the area where soil is to be placed.
- g. With the soft gabion fabric in place, add a layer of soil 14 inches to 16 inches thick (loose) and compact to a layer 10 inches to 12 inches thick. Containment boards shall be used to contain the outer edge or nose of the soft gabion and prevent soil from being cast down the slope or into the water.
- h. After the soil has been compacted roll the  $\frac{1}{2}$  of the fabric that was not covered by the soil over the top of the soil to form a coir pillow or soft gabion filled with soil.
- i. Using dead stout stakes anchor the selvage edges of the fabric into the back wall of the cut-bench area. The Contractor shall exercise care when anchoring the ends of the soft gabion to avoid having soil emigrate out of the soft gabions and to reduce the risk of failure at the ends of the gabions.
- j. During dry weather conditions the Contractor shall irrigate each brush layer/soft gabion combination.
- k. The Contractor shall continue steps (e) through (i) until the desired elevation has been reached and the bank or slope stabilization area is fully treated.

C. Cellular Confinement Systems:

1. General Description: The cellular confinement system is a three dimensional system used for soil stabilization. It is defined as a series of symmetrical shaped cells joined together sharing common walls such that the final system confines infill material within the cells and reduces both vertical and lateral movement.
2. Construction Sequence:
  - a. The Contractor shall verify site conditions are as shown on the Contract Drawings. Notify the Engineer if site conditions are not acceptable. The Contractor shall not begin preparation or installation until unacceptable conditions have been corrected or the Engineer has authorized initiation of work.
  - b. The Contractor shall install the cellular containment system according to standard practices recommended by the manufacturer in accordance with the purpose of the application.
  - c. The Contractor shall prepare the subgrade in accordance with manufacturer's specifications. Excavate or fill foundation soils so the top of installed cellular confinement system is flush with or slightly lower than adjacent terrain or final grade.
  - d. Anchor cellular confinement sections at crest of slope. Use type of anchor and frequency of anchoring indicated on the Contract Drawings or as directed by the Engineer or per the Manufacturer's specifications.
  - e. Expand cellular confinement sections down slope. Ensure each Geoweb section is expanded uniformly to required dimensions and outer cells of each layer are correctly aligned. Interleaf or overlap edges of adjacent sections in each layer, according to which sidewall profiles abut. Ensure upper surfaces of adjoining Geoweb sections are flush at joint and adjoining cells are fully anchored. Anchor with specified anchors per manufacturer's recommendations.
  - f. Place infill in expanded cells with suitable material handling equipment, such as a backhoe, front-end loader, conveyor, or crane-mounted skip. Limit drop height to a maximum of 1 m (3 feet). Avoid displacement of cellular confinement



sections by infilling from the crest to toe of slope. Overfill and compact infill in accordance with consistency of material and cell depth as follows: overfill screened topsoil between 25 50m (1 to 2-inches) and lightly tamp or roll to leave soil flush with top edge of cell walls. Apply specified surface treatment.

E. Live Staking:

1. Construction Sequence:

- a. Plants shall be planted when willow, or other species suitable for use in vegetated riprap projects, is dormant. This period extends from the time the leaves start to turn yellow in the autumn to the time new growth starts in the spring. The Contractor shall schedule plant material installation for early spring just before the plants come out of the dormancy period.
- b. Prior to installation the Contractor shall dip the butt end of all plant specimens (i.e. live stacks) into a liquid mycorrhizae root dip gel (rooting hormone with soil bacteria) to stimulate root growth.
- c. Live stakes shall be planted right side up with the butt ends planted into the ground. In order to identify the top of the stakes, the butt ends should be pointed or otherwise marked at the time of cutting. Alternatively the tops of the stakes may be painted with a water-soluble latex paint.
- d. The Contractor shall ensure that live stakes are to be planted as deep as possible. About 80 percent of the stake shall be inserted into the ground. The Contractor shall avoid stripping the bark or bruising the stake. The Contractor shall not pound the stakes with an ax or sledge. In hard ground the Contractor shall use an iron bar to prepare holes for the cuttings.
- e. The Contractor shall tamp soil around the live stakes after they have been placed into the ground. The live stakes shall be firm in the ground so that they cannot be easily moved or pulled out. ]

### 3.07 IRRIGATION (WATERING)

- A. Short-term Irrigation: Trees and shrubs shall be thoroughly soaked after planting and provided with additional water at intervals necessary to

provide for good health and growth of the planting. The Contractor shall be responsible for ensuring that adequate short-term irrigation is provided for the project.

1. The Contractor is responsible for providing water for irrigation and must adhere to all related legal and permit requirements.
2. Upon completion of planting, all planted and seeded areas within the project site shall be soaked to saturation by a fine spray. The new plantings and seedings shall be watered by an on-site sprinkling system during dry weather or whenever necessary for proper establishment of the planting and/or seeding until final project acceptance.
3. At no time shall the planting be allowed to dry out.
4. The Contractor shall implement appropriate measures to avoid excessive watering, soil washing (sheet erosion), excessive soil saturation, and/or areas of excess standing surface water.
5. Any damage to soils or plants that result from the Contractor's excessive or irregular irrigation (watering) practices shall be repaired within 24-hours by the Contractor at no additional cost to the OWNER.
6. Long-term Irrigation: The Contractor shall be responsible for providing an appropriate irrigation system to allow for watering of planted and seeded areas, that were constructed during as part of the project.
7. The Contractor shall provide irrigation after the initial construction period and throughout the maintenance and guarantee period. This Contractor responsibility extends to any performance monitoring periods that may be associated with agency permits issued to authorize the project work.
8. The Contractor shall review all short-term and long-term irrigation system proposals with the Engineer to ensure that said systems are adequate. No irrigation systems shall be installed or implemented without review and approval by the Engineer. Approvals from the Engineer shall be obtained 2-weeks prior to the time to begin required irrigation.

### **3.08 MAINTENANCE PRIOR TO ACCEPTANCE**

- A. The Contractor shall maintain the planted areas in a satisfactory condition until final acceptance of the project. Such maintenance shall include the

filling, leveling, and repairing of any washed or eroded areas, as may be necessary, and sufficient watering to maintain the plant materials in a healthy condition. The Engineer may require replanting of any areas in which the establishment of the vegetative ground cover does not appear to be developing satisfactorily.

1. Plants shall be maintained in a vigorous, thriving condition by watering, cultivating, weeding, pruning, spraying, and other operations necessary. No trees or shrubs will be accepted unless they are healthy and show satisfactory foliage conditions.
- B. At time of acceptance of the completed project, all seeded areas shall be totally established with no bare spots. In addition, all seeded areas shall have no more than 5 percent aerial coverage by non-native invasive plant species and 0 percent aerial coverage by noxious weeds.
- C. At the time of acceptance of the complete project all planted areas shall have a minimum of 85 percent survival of vegetative species (trees, shrubs, perennials).
- D. Vegetation/Pest Management:
1. Maintenance of grass species within the erosion control areas outside a critical wildlife or fish habitat areas shall be undertaken using conventional mowing, trimming, weeding, and other vegetative management techniques.
  2. The Contractor shall remove all noxious weeds and non-native, invasive plant species from within the project areas as regularly as necessary to prevent establishment of any noxious or non-native, invasive plant species.
  3. The Contractor shall be responsible for the removal of animal pest species from the project area if said pest species are adversely impacting the health of the erosion plantings or seedings.
    - a. The Contractor shall submit a plan for pest control to the Engineer detailing the pest problems and the recommended approach for controlling and/or eliminating said pest problems within the project area.
    - b. The Contractor shall, through consultation with appropriate Federal, state, and local agencies, determine the regulatory requirements related to pest control.
  4. Pesticide and herbicide use shall be implemented in accordance with all applicable Federal, state, and local regulations and policies.

- a. The Contractor shall be responsible for acquisition of all permits and licenses require for use and application of pesticides and herbicides.
  - b. The Contractor shall be responsible for appropriate storage and disposal of all chemical agents used within the project site for the purposes of controlling or eradicating pests or undesirable vegetation.
  - c. The Contractor shall be responsible for all “chain of custody” requirements associated with all chemical constituents used for the control and/or eradication of pest and/or undesirable vegetation.
  - d. The Contractor shall not use pesticides and/or herbicides in critical wildlife and fish habitats (i.e. riparian zones, nesting cover, etc.)
  - e. The Contractor shall employ a licensed pesticide applicator as required by any Federal, State or local laws.
- E. The Contractor shall provide adequate protection to all newly seeded areas including the installation of approved temporary fences to prevent trespassing and damage, as well as erosion control, until the end of the one-year correction period.
- F. The Contractor shall replace any materials or equipment damaged by its employees or subcontractors.
- G. The Contractor shall periodically inspect all erosion control blankets and matting following installation, particularly after rainstorms, to check for erosion and undermining. Any dislocation or failure shall be repaired within 24 hours. If washouts or breakage occurs, the Contractor shall reinstall the material after repairing the damage. The Contractor shall continue to monitor the project until it becomes permanently stabilized.

### **3.09 FINAL INSPECTION, ACCEPTANCE, AND GUARANTEE**

- A. Inspection of seeding and planting work shall be completed at conclusion of the maintenance period.
- B. Written notice requesting inspection shall be submitted to the Engineer and Owner at least 10 days prior to the anticipated inspection date.

- C. The Contractor shall submit inspection reports and/or maintenance records to the permitting agencies that have the ultimate approval authority with regard to when an erosion control project is successful.
- D. Final acceptance of the work prior to beginning the guarantee period of the contract will be accepted upon written approval by the Engineer and/or Owner, which is based on the satisfactory completion of all work, including maintenance, but exclusive of the replacement of plant material or any required seeding.
- E. The Contractor shall replace, as soon as weather conditions permit, all dead plants and all plants not in a vigorous, thriving condition, which are observed at the end of the one-year correction period.
- F. Plants used for replacement shall be of the same size and variety specified in the Contract Documents unless otherwise directed by the Engineer. Plants shall be furnished, planted, staked, and mulched as specified in the Contract Documents.
- G. At time of final acceptance of the completed project, all seeded areas shall be totally established with no bare spots. In addition, all seeded areas shall have no more than 5 percent aerial coverage by non-native invasive plant species and 0 percent aerial coverage by noxious weeds.
- H. At the time of acceptance of the completed project all areas where bank stabilization techniques were implemented shall have a minimum of 85 percent survival of vegetative species (trees, shrubs, perennials) installed. In addition, the vegetative species (trees, shrubs, perennials) shall provide 85 percent aerial cover.
- I. Prior to final acceptance the Contractor shall provide the Engineer with a written report (with photographs) documenting the condition of onsite plants and seedings. This report shall be used as part of the final project inspection and acceptance.

### **3.10 MAINTENANCE/GUARANTEE AFTER ACCEPTANCE**

- A. The Contractor shall be responsible for a period of one year after date of acceptance of all work under the Contract, for all plant replacements including trees, shrub seedlings, perennials and any other portion of the bank stabilization treatment requiring maintenance or replacement.
- B. The work covered by the maintenance and guarantee portions of these specifications consists of providing all replacements of plants, labor, materials, equipment, and supplies and performing all operations in connection with maintenance and guarantees.

- C. The Contractor shall provide the Engineer and OWNER with a monthly record describing all maintenance activities performed including dates, materials, irrigation schedule and other pertinent activities. The person who actually supervised and/or performed the work shall sign the report.
- D. The inspection of seeded areas is independent of the final inspection and maintenance period.

END OF SECTION

(This page is intentionally blank)

---

**SECTION 02273**

**Riprap**

**PART 1 – GENERAL**

**1.01 SCOPE**

- A. The Contractor shall provide stone riprap, including associated earthwork and geotextile filter material, complete and in place, in accordance with the Contract Documents.

**1.02 REFERENCED SPECIFICATIONS, CODES, AND STANDARDS**

- A. This Section references the following Commercial Standards:

Georgia Department of Transportation (GA DOT), Standard Specifications Construction of Roads and Bridges, 1993 Edition

ASTM C 88            Standard Test Method for Soundness of Aggregates by Use of Sodium Sulfate or Magnesium Sulfate

ASTM C 535        Standard Test Method for Resistance to Degradation of Large Size Coarse Aggregate by Abrasion and Impact in the Los Angeles Machine.

AASHTO T 85       Standard Method of Test for Specific Gravity and Absorption of Coarse Aggregate

AASHTO T 210     Method of Test for Aggregate Durability Index.

AASHTO T 134     Optimum Moisture Content

**1.03 CONTRACTOR SUBMITTALS**

- A. The Contractor shall submit samples of all materials proposed to be used in the work in accordance with the requirements in Section GC-28 – Working Drawings, Shop Drawings, Data on Material and Equipment, Samples and Licenses. Sample size shall be as determined by the testing laboratory.
- B. Testing certificates from a qualified testing agency shall be submitted prior to acceptance of the rock source to verify the conformity to the requirements of the Contract Documents. Contractor shall, if requested, coordinate inspection of the rock source by the Engineer.



PART 2 – PRODUCT

**2.01 STONES FOR RIPRAP**

- A. All Stone for riprap shall be sound, durable pieces of quarried stone weighing 156-pounds per cubic foot or more. The stone shall be angular and random in shape; rounded boulders or cobbles shall not be used. Flat, slabby, or shaley pieces will not be acceptable. Stones shall be resistant to weathering and to water action and free from overburden, spoil, and organic material and shall meet the gradation requirements below.
- B. Riprap shall be of the type indicated on the Drawings and shall conform to the size types as follows:

**Type 2** – equivalent to GA DOT specification for “Plain Riprap”:

Percent by Weight	Volume (cu.ft.)	Weight (lb.)	Diameter (in.)
65 – 100 %	0.75 – 2.0	125 - 320	15 – 24
10 – 65 %	0.04 – 0.75	7 - 125	5 – 15
0 – 10 %	0.0 – 0.04	0 - 7	0 – 15

**Type 3** – equivalent to GA DOT specification for “Dumped Riprap – Type 3”:

Percent by Weight	Volume (cu.ft.)	Weight (lb.)	Diameter (in.)
65 – 100 %	0.10 – 1.0	17 – 65	6 – 18
10 – 65 %	0.01 – 0.1	2 – 17	2 – 6
0 – 10 %	0.0 – 0.01	0 - 2	0 – 2

- C. Stones shall consist of durable, sound, hard, angular rock meeting the following requirements for durability absorption ratio, soundness test, and abrasion test:

Durability Absorption Ratio	Acceptability
Greater than 23	Passes
10 to 23	Passes only if Durability Index is 52 or greater
Less than 10	Fails
Durability Absorption Ratio	= $\frac{\text{Durability Index (Coarse)}}{\% \text{ absorption} + 1}$

- D. The durability index and percent absorption shall be determined by AASHTO T 210 and AASHTO T 85, respectively. The minimum apparent specific gravity of the stones shall be 2.5 as determined by AASHTO T 85.
- E. Stones shall have less than 10 percent loss of weight after five cycles, when tested per ASTM C 88.

- F. Stones shall have a wear not greater than 40 percent, when tested per ASTM C 535.
- G. Control of gradation shall be by visual inspection. The Contractor shall furnish a sample of the proposed gradation of at least 5 tons or 10 percent of the total riprap weight, whichever is less. If approved, the sample may be incorporated into the finished riprap at a location where it can be used as a frequent reference for judging the gradation of the remainder of riprap. Any difference of opinion between the Engineer and the Contractor shall be resolved by checking the gradation of two random truckloads of stones. Arranging for and the costs of mechanical equipment, a sorting site, and labor needed in checking gradation shall be the Contractor's responsibility.
- H. The acceptability of the stones will be determined by the Engineer prior to final placement.

## **2.02 GEOTEXTILE FABRIC FILTER**

- A. Geotextile fabric shall meet the requirements of GA DOT Section 881.06 for woven fabrics, having physical properties as follows:

Tensile Strength - any direction (ASTM D 4634)	200 lbs
Bursting Strength (ASTM D 3786)	500 psi
Elongation Before Breaking (ASTM D 4634)	10 – 35%
Percent Open Area (GDT: 88)	4.0 – 6.0%

- B. Fabric shall be Mirafi Filterweave 403 or approved equal.

## **PART 3 – EXECUTION**

### **3.01 SURFACE PREPARATION**

- A. Surfaces to receive filter materials and riprap, including the toe trench and slope, shall be brought to the line and grade indicated and shall be smooth and firm, free of brush, trees, stumps, and other objectionable material. Where filling of depressions is required or a filled bank is constructed, the new material shall be compacted with hand or mechanical tampers to a minimum of 85-percent of maximum density.
- B. The Contractor shall remove and exclude all stormwater, groundwater and creek or stream water from the excavation. Sump pumps and sand bags or portable dams, diversions, or other approved means, shall be used to remove and exclude water and continuously maintain water level below

the bottom of the excavation. Water shall be removed and excluded until both geotextile filter material and riprap have been placed. Any water removed from the excavation shall not be discharged into any surface stream or other water body unless such discharge meets water quality standards. Removed water may be disposed on-site by land application using sprinklers in an area designated by the Engineer or by discharge into an approved treatment system.

- C. Cleared and excavated materials shall be hauled off site to an appropriate disposal location arranged by the Contractor and at its sole expense unless otherwise indicated or specified.
- D. Riprap installed at the toe of a stream bank below the elevation of the water in a stream to prevent scour from undermining the riprap shall be backfilled and covered with native soil to the original grade. The backfilled native soil shall be compacted with hand or mechanical tampers to a minimum of 80-percent of maximum density.

### **3.02 PLACEMENT OF GEOTEXTILE FABRIC**

- A. The fabric shall be placed with the long dimension running up the slope, with the upstream strip overlapping the downstream strip. Use a minimum of 2-foot overlap for each overlap. Use a wider overlap if recommended by the geotextile manufacturer.
- B. The fabric shall be placed loosely with sufficient folded or gathered material to prevent stretching and tearing during riprap placement.
- C. The fabric shall be anchored into place using securing pins with type and spacing as recommended by the manufacturer. In addition, the fabric shall be secured at the toe and crest of the slope using anchor trenches at least 2-feet deep. If a stream bank extends sufficiently above a stream such that riprap would not be installed to the top of the bank, then the fabric shall be anchored in a 2-foot deep trench up-slope from the top of the minimum free-board of 0.5 feet above the flow resulting from a 50-year, 24-hour storm runoff event.

### **3.03 STONE RIPRAP**

- A. Placement of riprap shall begin at the toe and proceed up the slope. The stones shall be placed, or dumped from a height of not more than three feet and placed with equipment or by hand. Sufficient hand work shall be performed to produce a neat and uniform surface, true to the lines and grades indicated on the Drawings.
- B. Dumped riprap shall be used only where there is an existing road access to the top and/or bottom of the stream bank. Riprap shall be dumped into

place, beginning at the toe and proceeding up the slope, and may be spread using suitable equipment. Care must be taken to prevent damage to the underlying filter material. Sufficient hand work shall be performed to produce a neat and uniform surface, true to the lines and grades indicated on the Drawings.

END OF SECTION

(This page is intentionally blank)

---

**SECTION 02399**

**CREEK CROSSINGS**

**PART 1 GENERAL**

**1.01 SCOPE**

- A. Furnish all labor, materials, equipment and incidentals required to complete the construction of the creek crossings as shown on the Drawings and/or specified herein.
- B. The work will include all excavation (except rock), sheeting, furnishing and installing the pipe, concrete encasement, backfilling the trench, rip rap, water handling, diversion of flow, restoring channel and grading and all other work necessary to complete the crossing.

**PART 2 PRODUCTS**

**(NOT USED)**

**PART 3 EXECUTION**

**3.01 CONSTRUCTION METHODS**

- A. The procedure and methods of diking, by-passing or otherwise restricting the flow of the creek during construction, excavating the trench and installing the pipe will be at the option of the Contractor, subject to the review of the Engineer and the requirements of the Contract. Before start of work, the Contractor shall submit a written outline of his proposed methods and supporting data, for review by the Engineer.
- B. Excavation in earth and rock, if encountered for the pipe, shall conform to the requirements specified under Section 02225, Trench Excavation and Backfill. The pipe trench shall be true in grade and alignment, and of sufficient width and depth to provide space for properly laying the pipe.
- C. Backfilling of the pipe shall be done with select excavated granular material. The top 18 inches (minimum) of the trench shall be riprap as specified in Section 02125.
- D. The banks of the creek and areas disturbed during pipe installation shall be restored to their original or better condition in accordance with requirements as specified in Section 02125 and details shown on the Drawings.

- E. Upon completion of the crossing, the creek channel shall be cleaned, the pipe shall be tested and the site cleaned of all debris.

**+ + + END OF SECTION 02399 + + +**

---

**SECTION 02491****Rehabilitation of Sanitary Sewer Manholes****PART 1 – GENERAL****1.01 SCOPE**

- A. This specification covers the work necessary to expose and raise existing sanitary sewer manholes to grade and to rehabilitate or replace existing sanitary sewer manholes. All work shall be performed only as directed by the Engineer or shown on the task order Drawings. The Work includes:
  - 1. Sealing to exclude infiltration; and/or
  - 2. Lining of manhole interiors; and/or
  - 3. Removal and replacement of manholes; and/or
  - 4. Replacement and/or removal of broken manhole covers and frames, corroded step irons or corroded ladders.
- B. The Contractor is responsible for field verification of location and condition of all manholes.
- C. The Contractor shall provide all labor, materials and equipment required to clean, raise, or rehabilitate the manholes.
- D. The Contractor shall comply with the City's and OSHA requirements for confined space entry.
- E. No manhole cover slabs shall be removed to undertake the work until prior notice has been given to the Engineer.
- F. Before commencing work at existing manholes, a perforated catch bucket (to retain particulate larger than U.S. No. 8 sieve, for subsequent removal), or similar, shall be fitted to the outgoing pipe from the manhole structure. Contractors shall strictly adhere to the requirement that construction debris and waste material be prevented from entering downstream sewers.
- G. The Contractor shall keep accurate records of the location of and nature of the rehabilitation work performed at each manhole as directed by the Engineer. The Contractor shall provide copies to the Engineer as required.



## 1.02 REFERENCE SPECIFICATIONS, CODES, AND STANDARDS

- A. The following references are part of this Specification. In case of conflict between the requirements of this Specification and those of the listed documents, the requirements of this Specification shall prevail. The latest edition of the following references shall be used:
1. ASTM C794 Test Method for Adhesion-in-Peel Elastomeric Joint Sealant
  2. ASTM D412 Test Methods for Vulcanized Rubber and Thermoplastic Rubbers and Thermoplastic Elastomers - Tension
  3. ASTM D882 Test Methods for Tensile Properties of Thin Plastic Sheeting
- B. Other ASTM standards as referenced in the Specifications below.

## 1.03 SUBMITTALS

- A. The Contractor shall submit the following information:
1. Written certification by the manhole rehabilitation system manufacturer stating that the applicator is approved to install the rehabilitation system specified. **(At Pre-construction Meeting)**
  2. Manhole rehabilitation system manufacturer's literature describing the rehabilitation system components, rehabilitation material utilized, including the materials' physical and chemical characteristics. **(At Pre-construction Meeting)**
  3. Experience record of a minimum of sixty (60) manholes rehabilitated within the last three (3) years. **(At Pre-construction Meeting)**
  4. Description of installation method including **(At Pre-construction Meeting)**:
    - a. Product Material Safety Data Sheets.
    - b. Maximum pot life, storage life and essential storage requirements of all rehabilitation materials
    - c. Mixing and proportioning requirements (as applicable).

- d. Environmental requirements for application and worker safety including ventilation, humidity, and temperature ranges.
  - e. Application film thickness per coat of activator and mastic (as applicable).
  - f. Curing time, including specific formulation requirements to provide specified setting time for foamed mastic (as applicable)
  - g. Wastewater flow control plan in accordance with Section 02750.
- B. Methodology, including detail drawing and necessary product data for finishing all anticipated pipe connections to rehabilitated manholes to prevent infiltration and exfiltration (e.g. anticipated pipe connections, including through pipe, side connections and drop connections). In the case of lining, such details shall be provided by the liner manufacturer or approved in writing by the liner manufacturer.

#### **1.04 QUALITY ASSURANCE**

- A. Materials and supplies provided shall be the standard products of manufacturers. The standard products of manufacturers other than those specified may be accepted if it is demonstrated that they are equal in composition, durability, and usefulness for the purpose intended. All material components of an installed lining system shall be supplied by a single manufacturer.
- B. The Engineer will inspect the rehabilitated manholes to evaluate the Contractor's work.

#### **1.05 RELATED SECTIONS**

- A. The Work of the following Sections apply to the Work of this Section. Other Sections of the Specifications, not referenced below, shall also apply to the extent required for proper performance of the Work.
- 1. Section 02511: Preconditioning and Cleaning Manholes and Sewers
  - 2. Section 02750: Wastewater Flow Control
  - 3. Section 02200: Earthwork
  - 4. Section 02140: Dewatering

## **1.06 TRIAL TEST AND METHODOLOGY REVIEW**

- A. The Contractor shall comply with the following conditions before a manhole rehabilitation technique becomes accepted as a viable option on a repeat basis:
  - 1. A successful demonstration of manhole rehabilitation, for a manhole chosen by the Engineer, shall be carried out including type and quality control tests as recommended by the manufacturer and in compliance with industry standards.
  - 2. The trial shall be performed prior to approval for adoption by the Engineer of the manhole rehabilitation technique to prove that the equipment, materials and installation methodology are fully acceptable to meet local conditions. Payment will be made through the applicable unit price for the work.
  - 3. The Contractor shall allow for any further requirement of the Engineer, subsequent to the trial, to modify the equipment, material and/or installation methodology in order to complete the work satisfactorily and meet all testing standards, including vacuum testing of Rehabilitated Manholes, at no cost to the City.
- B. A representative from the manufacturer of the manhole rehabilitation system shall be present on-site for the entire duration of the trial test and methodology review. The manufacturer's representative shall certify in writing that the system applicator and/or installer has performed the application and/or installation in accordance with the manufacturer's requirements and recommendations.

## **PART 2 – PRODUCTS**

### **2.01 GENERAL**

- A. The installer shall warrant and hold harmless the City and the Engineer against all claims for patent infringement and any loss thereof.
- B. The materials used shall be designed, manufactured and specifically intended for sewer manhole rehabilitation and the specific application in which they are used. The materials shall have a proven history of performance in sewer manhole rehabilitation for a minimum of three (3) years in sewer systems elsewhere nationally, of similar age, groundwater levels and circumstance.

- C. The materials shall be delivered to the job site in original unopened packages and clearly labeled with the manufacturer's identification (brand name), date of manufacture, storage life and printed instructions.
- D. Stored materials shall be protected from weather and excessive heat or cold, and stored in accordance with the manufacturer's instructions. Flammable materials shall be stored in accordance with state and local codes. Materials exceeding storage life recommended by the manufacturer shall be removed from the site.
- E. The Contractor shall dispose of all wastes in accordance with applicable regulations.
- F. At the request of the Engineer, the Contractor shall provide a representative employed by the manufacturer having technical training in any of the specific manhole rehabilitation materials and/or system or technique being applied. The appropriate specialist shall be available for consultation on site within 48 hours notice, at no cost to the City.
- G. All completed rehabilitation work shall be resistant to:
  - 1. Continuous immersion in septic sewage at temperatures up to 85°F
  - 2. Continuous exposure to hydrogen sulfide gas from septic sewage at temperatures up to 85°F
  - 3. Deposits of free sulfur on exposed surfaces
  - 4. Continuous exposure to 10% sulfuric acid at temperatures up to 85°F

Seals shall be tested to withstand all subsequent infiltration, inflow, and exfiltration as specified herein.

## **PART 2A – MANHOLE INTERIOR RENEWAL**

### **2A.01 MANHOLE SEALING TO EXCLUDE INFILTRATION**

- A. General:
  - 1. Manholes will be sealed when active leaks are present, and/or will be patched when there is exposed aggregate (concrete manholes) or brick mortar missing (brick manholes) in small isolated areas.
  - 2. The generic chemical sealing materials to be used are listed with the basic properties, performance standards, and mix ratios that are

known to give acceptable performance.

3. In every case, mixing and handling of chemical sealing material shall be in accordance with the manufacturer's recommendations.

B. Characteristics of Sealing Chemicals:

1. All chemical sealing materials used in the performance of the work specified must have the following characteristics:
  - a. The chemical sealant must be able to react/perform in the presence of water (groundwater) while being injected, i.e., the sealant must be hydrophilic.
  - b. The cured material must withstand submergence in water without degradation.
  - c. The resultant sealant (grout) formation must prevent, on a continuing basis, the passage of water (infiltration) through manhole and sewer pipe joints.
  - d. The sealant material, after curing, must be flexible as opposed to brittle.
  - e. The sealant formation should be able to withstand freeze/thaw and wet/dry cycles without adversely affecting sealant properties. Note: This primarily applies to storm sewers, which are shallow and sometimes dry.
  - f. The sealant formation must not be biodegradable.
  - g. The cured sealant should be chemically stable and resistant to the mild concentrations of acids, alkalis, and organics found in normal sewage.
  - h. Packaging of component materials must be compatible with field storage and handling requirements. Packaging must provide for worker safety and minimize spillage during handling.
  - i. Mixing of the component materials must be compatible with field operations and not require precise measurements of the ingredients by field personnel.
  - j. Clean up must be done without inordinate use of flammable or hazardous chemicals.

- k. Residual sealing materials must be easily removable from the sewer line to prevent reduction or blockage of the sewage flow.

C. Acceptable Chemical Sealing Materials:

- 1. The following is a generic listing of permissible chemical sealing materials currently in use and the basic requirements, properties and characteristics of each.

- a. Acrylamide base gel sealing material:

- 1) A minimum of 10% acrylamide base material by weight in the total sealant mix. A higher concentration (%) of acrylamide base material may be used to increase strength or offset dilution during injection.
- 2) The ability to tolerate some dilution and react in moving water during injection
- 3) A viscosity of approximately 2 centipoise which can be increased with additives
- 4) A constant viscosity during the reaction period
- 5) A controllable reaction time from 10 seconds to 1 hour
- 6) A reaction (curing) which produces a homogeneous, chemically stable, non-biodegradable, firm, flexible gel
- 7) The ability to increase mix viscosity, density and gel strength by the use of additives

- b. Acrylic base gel chemical sealing material:

- 1) minimum of 10% acrylic base material by volume in the total sealant mix. A higher concentration (%) of acrylic base material may be used to increase strength or offset dilution during injection.
- 2) The ability to tolerate some dilution and react in moving water during injection

- 3) A viscosity of approximately 2 centipoise, which can be increased with additives
- 4) A constant viscosity during the reaction period
- 5) A controllable reaction time from 5 seconds to 6 hours
- 6) A reaction (curing) which produces a homogeneous, chemically stable, non-biodegradable, flexible gel
- 7) The ability to increase mix viscosity, density and gel strength by the use of additives

c. Urethane base gel chemical sealing material:

- 1) One (1) part urethane prepolymer thoroughly mixed with between 5 and 11 parts of water by weight. The recommended mix ratio is 1 part urethane prepolymer to 8 parts of water (11% prepolymer).
- 2) A liquid prepolymer having a solids content of 77% to 83%, specific gravity of 1.04 (8.65 pounds per gallon), and a flash point of 20°F
- 3) A liquid prepolymer having a viscosity of 300 to 1000 centipoise at 70°F that can be pumped through 500 feet of 1/2-inch hose with a 1000 psi head at a flow rate of 1 ounce per second
- 4) The water used to react the prepolymer should have a pH of 5 to 9.
- 5) Gel times shall be as short as practical and as short as two (2) minutes for polyurethane grouts, in accordance with the manufacturer's recommendations. Control of gel times is a critical aspect of successful chemical grouting. Higher water ratios give longer cure times.
- 6) A relatively rapid viscosity increase of the prepolymer/water mix in the first minute. (Viscosity increases from about 10 to 60 centipoise in the first minute for 1 to 8 prepolymer/water ratio at 50°F).
- 7) A reaction (curing) which produces a chemically stable and non-biodegradable, tough, flexible gel.

- 8) The ability to increase mix viscosity, density, gel strength and resistance to shrinkage by the use of additives to the water

d. Urethane base foam chemical sealing material:

- 1) Approximately one part of urethane prepolymer with one part of water by weight (50% prepolymer)
- 2) A liquid prepolymer having a solids content of 82 specific gravity of 1.1 (9.15 pounds per gallon) flash point of 200°F
- 3) A liquid prepolymer having a viscosity of 30 centipoise at 72°F that can be pumped through 50 feet of 1/2-inch hose with a 500 psi head at a flow rate of one ounce per second
- 4) A cure time of 15 minutes at 40°F, 8.2 minutes at 60°F 4.6 minutes at 100°F when the prepolymer is reacting with water only
- 5) A cure time of 5.5 minutes at 40°F, 8.2 minutes at 60°F, 2.6 minutes at 100°F when the prepolymer is reacting with water containing 0.4% accelerator
- 6) During injection; foaming, expansion, and viscosity increase occur.
- 7) Physical properties of the cured foam of approximately 14 pounds per cubic foot density, 80 to 90 psi strength, and 700% to 800% elongation when a mixture of prepolymer and 50% water undergoes a confined test and expands five times its initial liquid volume.
- 8) Acrylamide and acrylic gel grouts maintain a viscosity close to that of water (2 centipoise) during the time between mixing material solution with the activator solution and the formation of a gel. This time period is referred to as the cure time, induction period, or gel time. The low viscosity is advantageous for penetration but makes the grouts susceptible to dilution during the reaction period.
- 9) Urethane gel grout undergoes a viscosity increase during the time between mixing the base material with



water and the formation of a gel. This time period is cure time or gel time. The increasing viscosity limits penetration by dilution, particularly by groundwater.

## **2A.02 PATCHING**

- A. Manhole patching work includes re-pointing, filling, and repairing non-leaking holes, cracks, and spalls in concrete and masonry manhole walls, benches and slabs as well as through-flow channel dressing and repair.
- B. The patching material shall consist of a premixed non-shrink cement-based patching material consisting of hydraulic cement, graded silica aggregates, special plasticizing and accelerating agents, which has been formulated for vertical or overhead use. It shall not contain chlorides, gypsums, plasters, iron particles, aluminum powder, or gas forming agents or promote the corrosion of steel it may come into contact with. Set time (ASTM C-191) shall be less than 30 minutes. One hour compressive strength (ASTM C-109) shall be a minimum of 200 psi and the ultimate compressive strengths (ASTM C-882 Modified) shall be a minimum of 1700 psi.

## **PART 2B – MANHOLE LINING SYSTEMS**

### **2B.01 EPOXY BASED LINING SYSTEM**

- A. Manholes will be lined with epoxy or epoxy mortar when the manholes are subject to high groundwater levels (manholes near lakes/creeks, etc.) resulting in significantly active infiltration (runners and gushers) and/or subject to corrosive environments.
- B. Epoxy lining systems shall be completely watertight and free of any joints or openings other than pipe inlets and the rim opening. The junction of the lining material with the pipe material at the inlets and outlets shall be completely watertight.
- C. Each lining application shall be designed for application over damp (but not wet or active running water) surfaces without degradation of the final product and the bond between the product and the manhole surfaces.
- D. Generally, the entire interior walls of manholes as designated to be rehabilitated shall be lined with epoxy or epoxy mortar liner, as follows:
  - 1. The epoxy or epoxy mortar liner shall be used to form a monolithic liner covering all interior surfaces of the manhole, including benches and inverts.

2. The finished epoxy based monolithic liner shall conform to the following minimum requirements at 28 days:

PROPERTY	TEST METHOD	RESULTS
Compressive Strength	ASTM C-579	≥ 6,500 psi
Tensile Strength	ASTM C-307	≥ 2,500 psi
Flexural Strength	ASTM C-580	≥ 4,500 psi
Shrinkage	ASTM C-531	< 0.15%
Bond Strength	ASTM D-4541	Concrete failure

3. The finished manhole shall be resistant to corrosive conditions common to municipal wastewater and shall prohibit water infiltration.
4. The epoxy based liner shall be suitable for application over damp or dry concrete surfaces.
- E. At a minimum, the manhole rehabilitation epoxy or epoxy mortar liner system (product coating designation) must have received a passing score without receiving an N/E result in any category as documented in the following study:

“EVALUATION OF PROTECTIVE COATINGS FOR CONCRETE”  
August, 2002 Update

John A. Redner, Sewerage Departmental Engineer, Randolph P. Hsi, Associate Engineer, Edward J. Esfandi, Senior Engineer, Roger Sydney, Civil Engineer, Robin M. Jones, Associate Engineer, and Donna Won, Senior Engineer

County Sanitation Districts of Los Angeles County, Whittier, California.

- F. Acceptable systems include, but are not limited to, the following:
1. Raven 405 (Raven Lining Systems)
  2. Mainstay DS-4 (Madewell Products)
  3. Magma Quartz or Belzona 4111 (Belzona Inc.)
  4. Sauereisen-210 (Sauereisen)
  5. Warren Epoxy Spray or Laminate (Warren Environmental)

## 2B.02 FIBERGLASS LINING SYSTEM

- A. Manholes will be lined with a cured-in-place fiberglass insert when the manhole interior is structurally deteriorated (concrete or brick manholes), and/or subject to a corrosive environment.
- B. The fiberglass lining system shall consist of a three layer composite, laminate system comprised of one non-permeable synthetic, environmental membrane embedded and bonded between two layers of structural fiberglass woven fabric impregnated with a modified epoxy resin system. The average wall thickness of the fiberglass liner system shall be no less than 0.5-inch unless otherwise allowed, but shall be structurally designed to withstand all structural loads.
- C. The finished fiberglass liner shall conform to the following minimum physical properties:

PROPERTY	TEST METHOD	RESULTS
Max. Flexural Fiber Stress	ASTM D-790	≥ 44,000 psi
Flexural Modulus of Elasticity	ASTM D-790	≥ 1,000,000 psi
Compressive Strength	ASTM D-695	≥ 11,000 psi
Compressive Modulus	ASTM D-695	≥ 900,000 psi
Strength at Break	ASTM D-638	≥ 28,000 psi
% Elongation at Break	ASTM D-638	< 9%
% Elongation at Max. Load	ASTM D-638	< 2%

- D. Acceptable products are equal to Poly-Triplex PTL5-6800 series manufactured by Poly Triplex Technologies, Inc.

**2B.03 CEMENTITIOUS LINING SYSTEM**

- A. Manholes will be lined with cementitious lining for preventive maintenance when the manhole interior is mildly weathered or aged, and/or subject to minor infiltration (seepers or drippers).
- B. Cementitious lining systems shall be completely watertight and free of any joints or openings other than pipe inlets and the rim opening. The junction of the lining material with the pipe material at the inlets and outlets shall be completely watertight.
- C. Each lining application shall be designed for application over damp (but not wet or active running water) surfaces without degradation of the final product and the bond between the product and the manhole surfaces.
- D. Generally, the entire interior walls of manholes as designated shall be lined with calcium aluminate cementitious liner, as follows:

1. The calcium aluminate cementitious liner shall be used to form a monolithic liner covering all interior surfaces of the manhole, including benches and inverts.
2. The finished cementitious liner shall conform to the following minimum requirements at 28 days:

PROPERTY	TEST METHOD	RESULTS
Compressive Strength	ASTM C-109	≥ 8,000 psi
Tensile Strength	ASTM C-496	≥ 800 psi
Flexural Strength	ASTM C-293	≥ 1,500 psi
Shrinkage (@ 90% R.H.)	ASTM C-490	0%
Bond Strength	ASTM C-882	≥ 2000 psi

3. The finished manhole shall be resistant to corrosive conditions common to municipal wastewater and shall prohibit water infiltration.
- E. The cementitious liner mix shall be factory blended requiring only the addition of water at the jobsite. The liner mix shall be suitable for “wet” application by progressive cavity pump type equipment only. Gunite mixes will not be allowed.
  - F. The liner applicator must use approved equipment designed and/or approved by the material manufacturer specifically for the application of cementitious liners in manholes. Only low-pressure, progressive cavity pump type equipment for “wet” application will be allowed.
  - G. Acceptable systems are those equal to:
    1. Strong-Seal® by The Strong Company, Inc.;
    2. Sewpercoat® by Lafarge Calcium Aluminates, Inc.;

**PART 2C - MANHOLE RAISING/ADJUSTMENT TO GRADE**

**2C.01 GENERAL**

- A. Brick
  1. Brick shall conform to ASTM C-32 for grade SM. Bricks shall conform to the following dimensions, unless otherwise approved by the Engineer:

	Depth	Width	Length
	(inches)	(inches)	(inches)

Standard Size	2 ¼	3 ¾	8
Allowable Variation	± ¼	± ¼	± ½

2. All brick shall be new and whole, or uniform standard size and with substantially straight and parallel edges and square corners. Bricks shall be of compact textures, burned hard entirely through, tough and strong, free from injurious cracks and flaws, and shall have a clear ring when struck together. No soft or salmon brick shall be used except at such places, to such extent, and under such conditions as may be approved by the Engineer.

**B. Mortar**

1. The Contractor shall use mortar meeting the requirements of ASTM C-270 Type S unless directed otherwise by the Engineer.
2. The Contractor shall prepare mortar only in quantities needed for immediate use. Mortar which has been mixed for more than 30 minutes, which has set, or which has been retempered shall not be used.
3. No mortars utilizing latex emulsifiers or plasticizers as a filler are acceptable. No bonding agents are allowed.

**C. Cast Iron Adjustment Rings**

1. For adjusting lid elevation: Adjusting rings shall be cast iron equal to Series R-1979-H (heavy duty) manufactured by Neenah Foundry.
2. All adjusting rings shall be securely sealed to the casting frame using resilient, flexible, non-hardening, preformed butyl mastic equal to Rub R Nek or EZ Stick. This mastic shall be applied in such a manner that no surface water or ground water inflow can enter the manhole through gaps between the first adjusting ring, between adjusting rings, or between the last adjusting ring and the manhole frame. Up to two (2) inches of adjusting rings may be installed on a given manhole. No more than two (2) adjusting rings in total shall be used for the final adjustment to grade.

**D. Concrete Grade Rings**

1. For manhole adjustment to grade: Pre-cast concrete grade rings may be used instead of brick and mortar for adjusting pre-cast concrete manholes to grade. The pre-cast concrete rings shall be installed between the top of the cone and the casting frame. Grade

rings shall be pre-cast concrete, as manufactured by Standard Concrete Products (lightweight) or approved equal.

2. All grade rings shall be securely sealed to the bottom of the casting frame and the top of the cone using a resilient, flexible, non-hardening, preformed butyl mastic equal to Rub R Nek or EZ Stick. No less than two beads shall be applied 1/2 inch wide and 3/4 inch high between grade rings when grade rings are stacked. No less than one inch of non-shrink cement based patching material shall be applied to the inside and outside faces of the grade rings when grade rings are stacked.

## 2C.02 MANHOLE CASTING EMBEDMENT SEALANT TO EXCLUDE RDI/

- A Provide a premium, extruded bituminous tacky rubber sealant in rope form for use on manholes as an embedment material for the frame to adjusting brick/mortar corbel.
- B. Sealant shall conform to AASHTO M-198 Type B and SS-S-210 and SS-S-210A.

C. Properties:

1. Chemical Composition:

Hydrocarbon Plastic Content % by wt	SPEC REQUIRED
Inert Mineral Filler % by wt	ASTM D4 (mod.) 50-70
Volatile Matter % by wt	SS-S-210A 30-50
	ASTM D6 3.0 max
2. Physical Properties:

Specific Gravity, 77°F	ASTM D71 1.20-1.35
Ductility, 77°F	ASTM D 113 5.0 min
Softening Point	ASTM D36 320 min
Flash Point, C. 0. C. min	ASTM D92 600 min
Fire Point, C. 0. C. min.	ASTM D92 625 min
Penetration, 77°F (150 gm) 5 sec.	ASTM D217 50 to 120
3. Chemical Resistance:

30-Day Immersion: No visible deterioration when tested for 30 days in 5% caustic potash, 5% hydrochloric acid, 5% sulfuric acid, or 5% saturated hydrogen sulfide

Elongation Initial, 77°F	300% min
Two Weeks, Total Water Immersion	300% min
Flow Resistance (one inch wide overhead joint exposed to 135°F for 7 days)	No Flow
Storage Life	Indefinite
Application Temperature Range	10 to 125°F
Service Temperature Range	-20 to 200°F

## PART 2D – REPLACEMENT MANHOLE FRAMES AND COVERS

### 2D.01 GENERAL

- A. New manhole covers and frames shall conform to the requirements of the City's standard and standard details.
- B. Frames and covers shall be Neenah Foundry, Series R-1700 (heavy duty) or equivalent. Light duty covers shall not be used.
- C. Where manholes are located in flood plains, frames and covers shall be Neenah Foundry, Series R-1700 (heavy duty) or equivalent. Light duty covers shall not be used. The top surface of the frame and covers shall have bolt down lids with a watertight gasket.

### 2D.02 ELASTOMERIC CORBEL SEAL TO EXCLUDE RDI/I

- A. Provide a frame-to-manhole elastomeric seal consisting of a two component, aliphatic chemical curing, urethane sealant formulated as a high build coating to seal the casting to the manhole corbel. The purpose is to stop infiltration by the application of a corrosion resistant flexible coating to be applied to the inside wall. The corrosion resistant flexible urethane shall be Flex-Seal Utility Sealant as manufactured by Sealing Systems, Inc., Loretto, or approved equal.

- B. Minimum Requirements for Flexible Aromatic Urethane Resin Liner Primer:

Hardness	ASTM-D2240	85 Brinell
Elongation	ASTM-D412	400%
Tensile Strength	ASTM-D412	3000 p.s.i.
Adhesive Strength	ASTM-D0903	3 50 lb./in.
Tear Resistance	ASTM-D1004	200 lb./in.

- C. Minimum Requirements for Flexible Aromatic Urethane Resin Liner Final Coat:

Hardness	ASTM-D2240	50 Brinell
Elongation	ASTM-D412	750 %
Tensile Strength	ASTM-D412	1100 p.s.i.
Adhesive Strength	ASTM-D0903	175 lb./in.
Tear Resistance	ASTM-DIO04	155 lb./in.

- D. Minimum Final Thickness: 80 mils.

## **PART 2E – REPLACEMENT MANHOLES**

### **2E.01 GENERAL**

- A. New manholes shall conform to the requirements of Section 02730 and the City's standard details.

## **PART 3 – EXECUTION**

### **3.01 PERFORMANCE REQUIREMENTS**

- A. Perform work needed to make manholes structurally sound, improve flow, prevent entrance of inflow or groundwater infiltration, and prevent entrance of soil or debris.
- B. Existing manhole shall be Preconditioned and Cleaned in accordance with Specification Section 02511 prior to any and all rehabilitation work.

### **3.02 PROJECT CONDITIONS**

- A. Manholes Containing Flow Monitoring Equipment:
  - 1. Drawings may not show locations of flow monitoring equipment. If a manhole contains any mechanical hardware or electrical flow monitoring equipment, immediately notify the Engineer.
  - 2. Reschedule work in such manholes until equipment has been removed by the City and further instructions are given, at no additional cost.
  - 3. Do not subject manholes with mechanical hardware or electrical equipment to bypass or diversion pumping.
  - 4. Damage to installed equipment, due to Contractor's failure to adhere to the above, will be repaired by the City and cost of repairs charged to Contractor.
- B. Field Location of Manholes:
  - 1. Manholes may be located within project limits, which are not part of the system being rehabilitated. Properly identify manholes before starting work. No payment will be made for work in manholes not indicated on the Drawings or not directed in writing by the Engineer



### **3.03 SALVAGE**

- A. Manhole covers and frames, as well as adjusting rings from abandoned, broken or adjusted manhole castings remain the property of the City. Deliver salvaged items to City's storage facility or as otherwise directed by the City at the conclusion of the project.

### **3.04 PROTECTION**

- A. Provide barricades and warning lights and signs for excavations created by manhole casting work in accordance with the drawings.
- B. Do not allow sand, debris or runoff to enter sewer system.

### **3.05 EXCAVATION**

- A. Excavate in accordance with City's Standard Specifications and Section 02200.
- B. Perform work in accordance with OSHA standards. Employ a trench safety system, as required for excavations.
- C. Install and operate necessary dewatering and surface water control measures as required.

### **3.06 FLOW BYPASS AND DIVERSION PUMPING**

- A. Install and operate bypass and diversion pumping equipment to maintain sewage flow and to prevent backup or overflow in accordance with Specification Section 02750 – Wastewater Flow Controls.

### **3.07 LINERS**

- A. General. The entire interior walls of manholes as designated on the drawings or instructed by the Engineer to be rehabilitated shall be lined with epoxy/epoxy mortar lining, cementitious lining or fiberglass lining system.
- B. All liners shall be installed in accordance with the manufacturer's written instructions.

### **3.08 EPOXY LINER**

- A. Storage, mixing, application and curing procedures shall conform to the recommendations of the monolithic epoxy or epoxy mortar liner manufacturer. The epoxy or epoxy mortar may be spray, trowel or brush

applied onto the interior surfaces of the manhole as recommended by the manufacturer.

- B. Surfaces shall be made free of oil, grease, water and other contaminants prior to application of the epoxy or epoxy mortar liner. An abrasive blast, high-pressure water blast, or acid etching shall be used to obtain a uniform sound substrate with a neutral pH prior to the application of the epoxy liner.
- C. After cleaning and prior to liner installation, all large voids and spalled areas shall be filled and patched with a suitable patching. The patching compound shall conform to the recommendations of the epoxy or epoxy mortar liner manufacturer.
- D. The epoxy or epoxy mortar lining system shall be installed to the manufacturer's recommended thickness and number of coat applications. No sagging of the liner on vertical surfaces shall be acceptable to the Engineer.
- E. The epoxy or epoxy mortar liner shall not be installed on surfaces in direct sunlight or when surfaces are subject to rising temperatures to prevent blistering of materials due to thermal expansion of trapped air or moisture in the substrate.

### **3.09 FIBERGLASS LINING SYSTEM**

- A. After cleaning and prior to liner installation, all large voids and spalled areas shall be filled and patched with a suitable patching compound. The patching compound shall be as recommended by the lining system manufacturer.
- B. The installation of the lining system shall be in strict accordance with the manufacturer's written installation procedures.
- C. After the liner system is installed it shall be cut and trimmed. The completed product shall be a permanent, monolithic, lined and impervious structure shaped to the interior of the existing manhole. The manhole shaft lining systems shall be completely water tight and free of any joints or openings other than pipe inlets, pipe outlets and the rim opening.
- D. All defective areas and imperfections including, but not limited to, poor adhesion, excessive void, and air bubbles shall be repaired in strict conformance with the recommendation of the lining system manufacturer and subject to the approval of the Engineer.

### 3.10 CEMENTITIOUS LINER

- A. Storage, mixing, application and curing procedures shall conform to the recommendations of the cementitious liner manufacturer. The cementitious liner shall be spray applied using a low-pressure, progressive cavity type pump onto the interior surfaces of the manhole as recommended by the manufacturer. Guniting or “dry” applications will not be allowed.
- B. Surfaces shall be made free of oil, grease, water and other contaminants prior to application of the cementitious liner. An abrasive blast, high-pressure water blast, or acid etching shall be used to obtain a uniform sound substrate with a neutral pH prior to the application of the cementitious liner.
- C. After cleaning and prior to liner application, loose and protruding brick, mortar, or concrete shall be removed and all large voids and spalled areas shall be filled and patched with a suitable patching compound. The patching compound shall conform to the recommendations of the cementitious liner manufacturer.
- D. The cementitious lining system shall be installed to the manufacturer’s recommended thickness and number of coat applications up to one-inch (1”) thickness, but not less than one-half-inch (1/2”) thickness. The finished surface shall then be trowel-finished and/or brush-finished to a relatively smooth finish.
- E. The freshly applied liner shall be protected from high-velocity surface drying or air movement.

### 3.11 MANHOLE BENCHES/THROUGH-FLOW CHANNELS

- A. Formation of Through-Flow Channel:
  - 1. Remove obstructions and loose materials from benches prior to shaping the through flow channel. Form a smooth, U-shaped channel having a minimum depth of one pipe diameter and channel it across the floor of the manhole using an approved manhole rehabilitation material as specified in Part 2. Control flow to allow sufficient setting time for material used.
  - 2. Form a smooth transition with a reshaped channel and a raised manhole bench to eliminate sharp edges of pipe and concrete bench. Build up and smooth through flow channel of manhole to match flow line of pipe.

3. Make finished benches and through flow channels smooth and without defects which would allow for accumulation of debris.

**B. Remedial Work to Existing Manhole:**

1. Exposed reinforcement shall be sand blasted, epoxy primed and protected by a premixed non-shrink cement-based patching material consisting of hydraulic cement, graded silica aggregates, special plasticizing and accelerating agents, which has been formulated for vertical or overhead use. It shall not contain chlorides, gypsums, plasters, iron particles, aluminum powder, or gas forming agents or promote the corrosion of steel it may come into contact with.

**C. Connection of Pipelines to Replacement Manholes:**

1. In connecting pipelines to replacement manholes, the Contractor shall ensure that the connections are watertight and that the existing sewers and replacement manholes are not damaged.
2. The Contractor shall ensure that there is no interruption to existing flows during the connection works.
3. The Contractor shall adjust replacement manhole benchings and bases to accommodate existing pipelines to ensure a continuous invert without steps.
4. All connections into manholes shall be designed and installed so as to ensure that groundwater is not permitted to enter the confines of the sewer or manhole. The Contractor shall submit proposals together with any material specification for making fully sealed connections into replacement manholes to the Engineer for approval.

### **3.12 REPLACEMENT MANHOLE FRAMES AND COVERS**

- A. Adjust all manhole frames and covers above or at grade, reset loose frames, and install elastomeric corbel seal.
- B. Where manholes are constructed in paved areas, the frame and cover shall be combined with brick work or cast iron adjustment rings so that the elevation of the top surface of the installed casting cover is flush with the surrounding pavement constructed to the exact slope, crown and grade of the existing adjacent pavement. Manholes in locally low-lying areas, where surface water may collect, may incorporate self-sealing covers or manhole inserts as directed by the Engineer. Inside surface of all manhole cover frames shall incorporate the unique 3-digit manhole number corresponding to the City's GIS identification number. The number shall be stenciled with

1.5-inch high epoxy painted figures on surface prepared to manufacturer's requirements. For example, if the 11-digit manhole number is 23250111401, the number 114 will be stenciled on the inside surface of the frame.

- C. Where manholes are constructed in paved areas in flood plains, the frame and covers shall have bolt down lids with a watertight gasket. The frame and cover shall be combined with brick work or cast iron adjustment rings so that the top surface of the installed casting cover is flush with the surrounding pavement constructed to the exact slope, crown and grade of the existing adjacent pavement. Inside surface of all manhole cover frames shall incorporate the unique 3-digit manhole number corresponding to the City's GIS identification number. The number shall be stenciled with 1.5-inch high epoxy painted figures on surface prepared to manufacturers requirements or as directed by the Engineer.
- D. Where manholes are constructed in non-pavement areas in flood plains or otherwise, the top surface of the frame and covers shall have bolt down lids with a watertight gasket, as directed by the Engineer. Manhole frame and covers in the wooded or un-maintained areas shall be 30-inches above grade when combined with brick work or cast iron adjustment rings. Manholes in grassed areas maintained as lawns etc., shall be adjusted to be flush with the ground unless otherwise directed. The inside surface of all manhole cover frames shall incorporate the unique 3-digit manhole number corresponding to the City's GIS identification number. The number be shall stenciled with 1.5-inch high epoxy painted figures on surface prepared to manufacturers requirements or as directed by the Engineer.

### **3.13 MANHOLE RAISING/ADJUSTMENT TO GRADE**

- A. The Contractor shall utilize maps, surveys, sounding instruments, or information from local residents to determine approximate location of buried manholes. Manholes shall be exposed utilizing hand techniques or by carefully probing with mechanical equipment. Manhole exposure in paved areas shall be accomplished by making a square cut in the surface with sufficient width to allow for the excavation of the material around the manhole to expose it to a depth necessary to facilitate adjustments.
- B. Manhole adjustment to grade is defined as raising the manhole cover (lid) elevation to grade by removing the casting frame, building up the manhole chimney to a maximum of 12 inches, then re-installing the frame and cover. The chimney may be built-up using brick and mortar or pre-cast concrete grade rings conforming to the requirements of this Section. Brick and mortar shall be used for manholes constructed of brick. Concrete grade rings shall be used for manholes constructed of concrete. A maximum adjustment of 12 inches will be allowed using brick and mortar or concrete grade rings between the bottom of the casting frame and the

top of the cone section. [Note: The 12-inches maximum is a cumulative limit – any existing brick or concrete in place between the frame and cone shall be included in the measurement of the allowable 12-inches.] Non-shrink mortar shall be applied to create a smooth finish on the interior and exterior prior to backfill. Cast iron adjusting rings may be used for either brick or concrete manholes to raise the cover (lid) at the top of the frame, if necessary for final adjustment. Up to two (2) inches of cast iron adjusting rings may be installed on a given manhole. No more than two (2) adjusting rings in total shall be used.

- C. Manhole raising to grade is defined as raising the manhole cover (lid) to grade by removing the casting frame, chimney and cone section, then rebuilding the manhole (with new components) up to grade in accordance with the Contract Drawings. Should any part(s) of the manhole below the cone be deemed incompatible with the new manhole components, then the entire manhole shall be removed and replaced to grade.

### **3.14 ELASTOMERIC CORBEL SEAL TO EXCLUDE RDI/**

- A. The surfaces on which the elastomeric seal is to be installed shall be circular, clean, reasonably smooth and free of any loose material and excessive voids. If the surface is rough or irregular and would not provide an effective seal, it shall be smoothed with an approved microsilica enhanced grout. Any flaw or flaws in the manhole frame such as cracks, pits or protrusions, shall be repaired by filling with concrete or grinding smooth. This type of surface work will need to be done on manholes that have not been lined. Manholes that have been lined should not need any surface work in order to install the seal.
- B. Installation of seal shall be as directed by the manufacturer's installation instructions. A manufacturer's representative will train the Contractor in the proper method of installing the seal and will assist the Contractor with any problems they might encounter installing the seals.
- C. Frame to manhole seals shall be installed in such a manner that will prevent water migration between the manhole frame and manhole structure.
- D. The lower 3 inches on the casting frame and top 3 inches of the corbel must be prepared according to the manufacturer's instructions. The corbel/casting interface area shall receive a thickened flexible urethane to achieve a thickness of 80 mils to 120 mils. The seal shall be applied by spray, brush, or trowel 3 inches above the bottom of the frame, and shall cover the entire area to 3 inches below the lowest of bottom of the frame or lowest adjusting ring.

### **3.15 INSPECTION AND TESTING OF COMPLETED MANHOLE**

- A. After manhole sealing or manhole lining has been completed, the surface of the installed liner shall be cleaned and prepared to permit visual inspection. Visually inspect the manhole in the presence of the Engineer. Check for cleanliness and for elimination of active leaks.
- B. Assist Engineer in verifying installation of lining thickness and sounding. Test points on the manhole wall where directed by the Engineer. Repair verification points prior to final acceptance of payment. The finished surface shall be free of blisters, "runs" or "sags" or other indications of uneven lining thickness. No evidence of visible leaks shall be acceptable. All costs for verification and testing shall be included in the unit price for manhole rehabilitation.
- C. In addition, at the City's request, the Contractor may be required within one year to visually inspect the manholes that were sealed or lined. Any work that has become defective within the one-year period shall be redone by the Contractor at no additional expense to the City.
- D. Vacuum testing is required for all manholes lined. This test must meet all requirements of Section 02730. The Engineer must be present during the test. All costs for vacuum testing shall be included in the unit price for manhole rehabilitation.

### **3.16 REPLACEMENT OF EXISTING MANHOLE**

- A. The Contractor shall replace manholes where shown on the Drawings, or as directed by the Engineer. The Contractor shall dispose of all materials from the removed manholes to a licensed landfill.

### **3.17 VACUUM TESTING**

- A. Rehabilitated and/or replaced pipelines and manholes shall be vacuum tested and/or low air pressure tested to detect possible points of infiltration in accordance with Section 02730. All inlets to the system shall be effectively closed and any residual flow shall be deemed to be infiltration. The attached form shall be used to document the test results.
- B. The Contractor shall include the cost of the vacuum test in the unit prices for rehabilitation or replacement for the purposes of carrying out the vacuum/low-pressure air test and all the foregoing requirements of this paragraph.

## **PART 4 – WARRANTY**

### **4.01 MATERIAL WARRANTY**

- A. A written guarantee of 5 years submitted to the City for the specific project shall be provided by the Manufacturers of the manhole rehabilitation materials.

### **4.02 WORKMANSHIP WARRANTY**

- A. A written guarantee of 2 years minimum shall be provided by the Contractor against any shortcoming in Workmanship.



(This page is intentionally blank)

# **ATTACHMENT A**

## **MANHOLE LEAKAGE TEST RESULTS**

### **VACUUM-AIR METHOD**

(This page is intentionally blank)

## MANHOLE LEAKAGE TEST RESULTS

### VACUUM-AIR METHOD

Work Order Number: \_\_\_\_\_ Date: \_\_\_\_\_

Project Description: \_\_\_\_\_

Contractor: \_\_\_\_\_ \*Manhole Diameter: \_\_\_\_\_

Specific Location of Test: \_\_\_\_\_

Manhole Depth 'A' From Flowline to Top of Cone(feet): \_\_\_\_\_

Initial Vacuum Gauge Reading: \_\_\_\_\_ **Must Be 10-inch Hg**

Time Test Must Be Conducted: \_\_\_\_\_ **In Seconds**

<b>MINIMUM TEST TIMES FOR VARIOUS MANHOLE DIAMETERS AND DEPTHS</b>			
<b>Depth 'A' (feet)</b>	<b>Minimum Test Times with a 4 ft. Diameter</b>	<b>Minimum Test Times with a 5 ft. Diameter</b>	<b>Minimum Test Times with a 6 ft. Diameter</b>
8	20	28	33
10	25	33	41
12	30	39	49
14	35	48	57
16	40	52	67
18	45	59	73
20	50	65	81
22	55	72	89
24	59	78	97
26	64	85	105
28	69	91	113
30	74	98	121

Final Vacuum Gauge Reading: \_\_\_\_\_ **Inches of Hg**

Is Final Vacuum Gauge Reading greater than or equal to 9" of Hg? **YES** or **NO**

Mark One:

If YES is marked above, the test has

PASSED

If NO is marked above, the test has

FAILED

Inspector's Signature: \_\_\_\_\_

- A. Per Manufacturer of Vacuum Test Unit. For a 60-inch Manhole Over 30 ft. deep, add 6.5 seconds for each 2-feet over 24-feet. depth to a base time of 78 seconds. Therefore,  $(((\text{Depth} - 24)/2) \times 6.5) + 78 = \text{Test Time In Seconds}$ .

END OF SECTION

(This page is intentionally blank)

# **ATTACHMENT B**

# **STANDARD DETAILS**

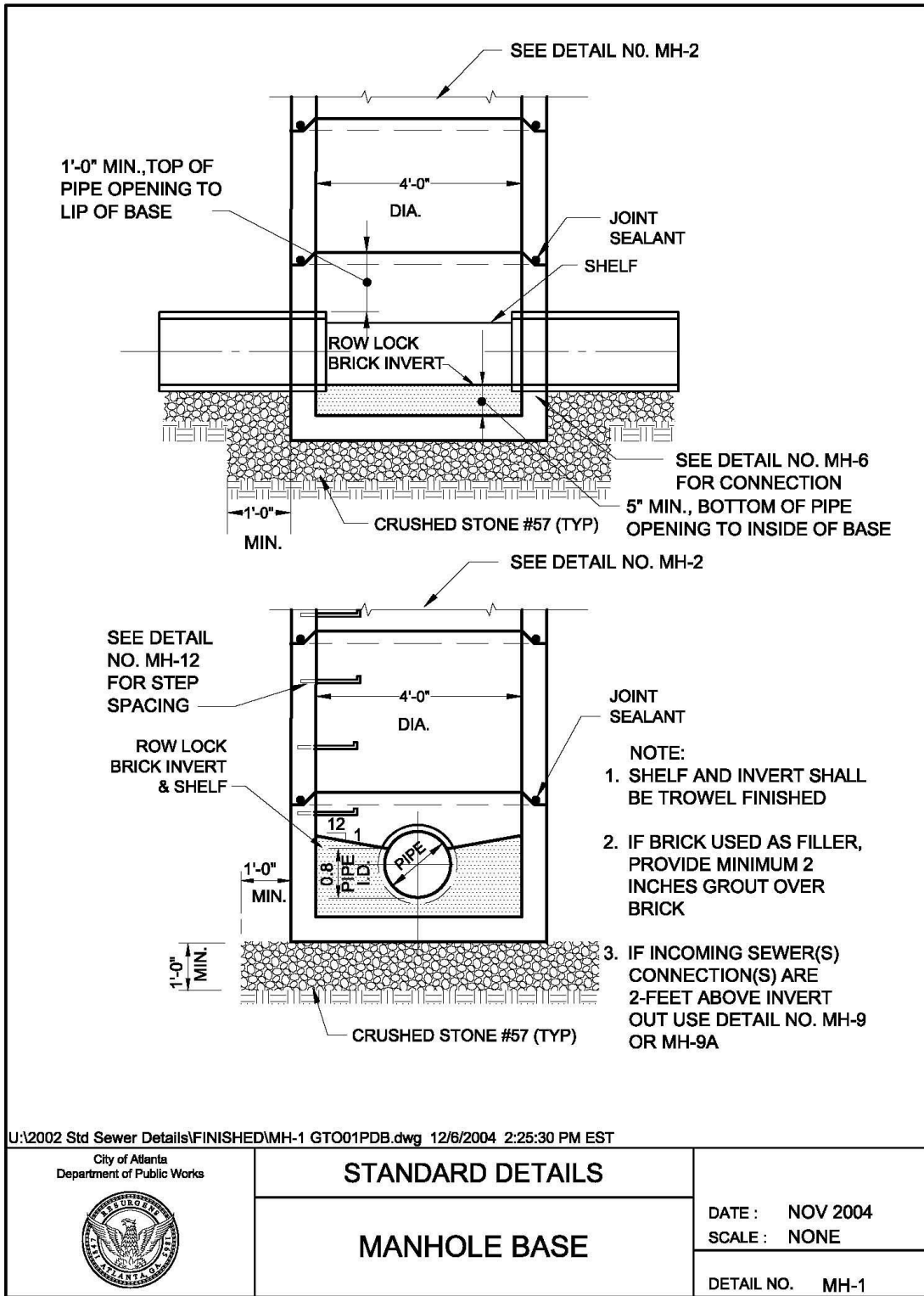

U:\2002 Std Sewer Details\FINISHED\MH-1 GTO01PDB.dwg, 12/18/2004 2:19:09 PM, CutePDF Printer

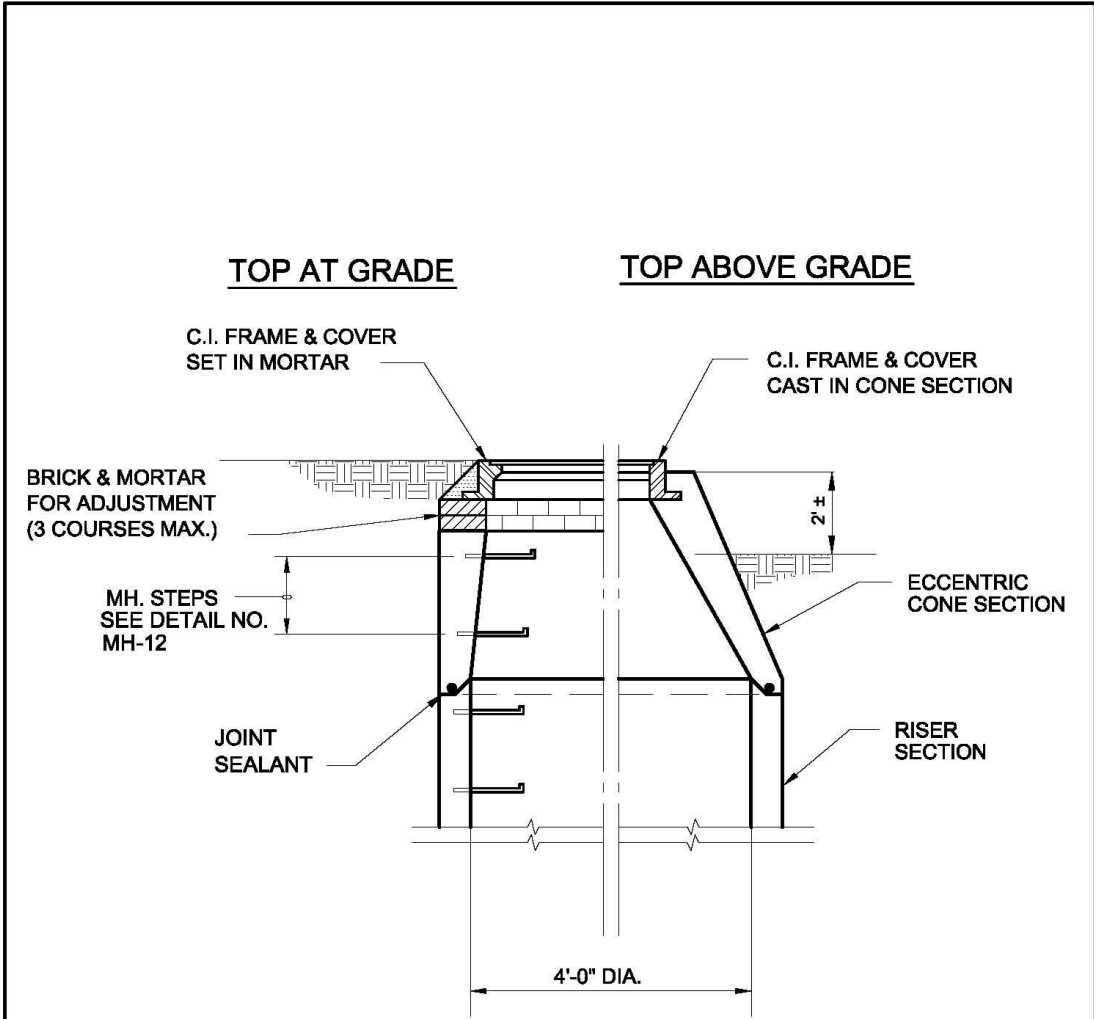

NOTE: FRAME & COVER SHALL BE CAST IN ALL CONE SECTIONS  
 UNLESS FRAME & COVER IS TO BE FLUSH WITH FINAL GRADE.

U:\2002 Std Sewer Details\FINISHED\MH-2 GTO01P23.dwg 12/6/2004 2:26:32 PM EST

City of Atlanta Department of Public Works 	<b>STANDARD DETAILS</b>	DATE : JAN 1997 SCALE : NONE
	<b>MANHOLE RISER AND CONE</b>	DETAIL NO. MH-2

U:\2002 Std Sewer Details\FINISHED\MH-2 GTO01P23.dwg, 12/8/2004 2:19:53 PM, CutePDF Printer



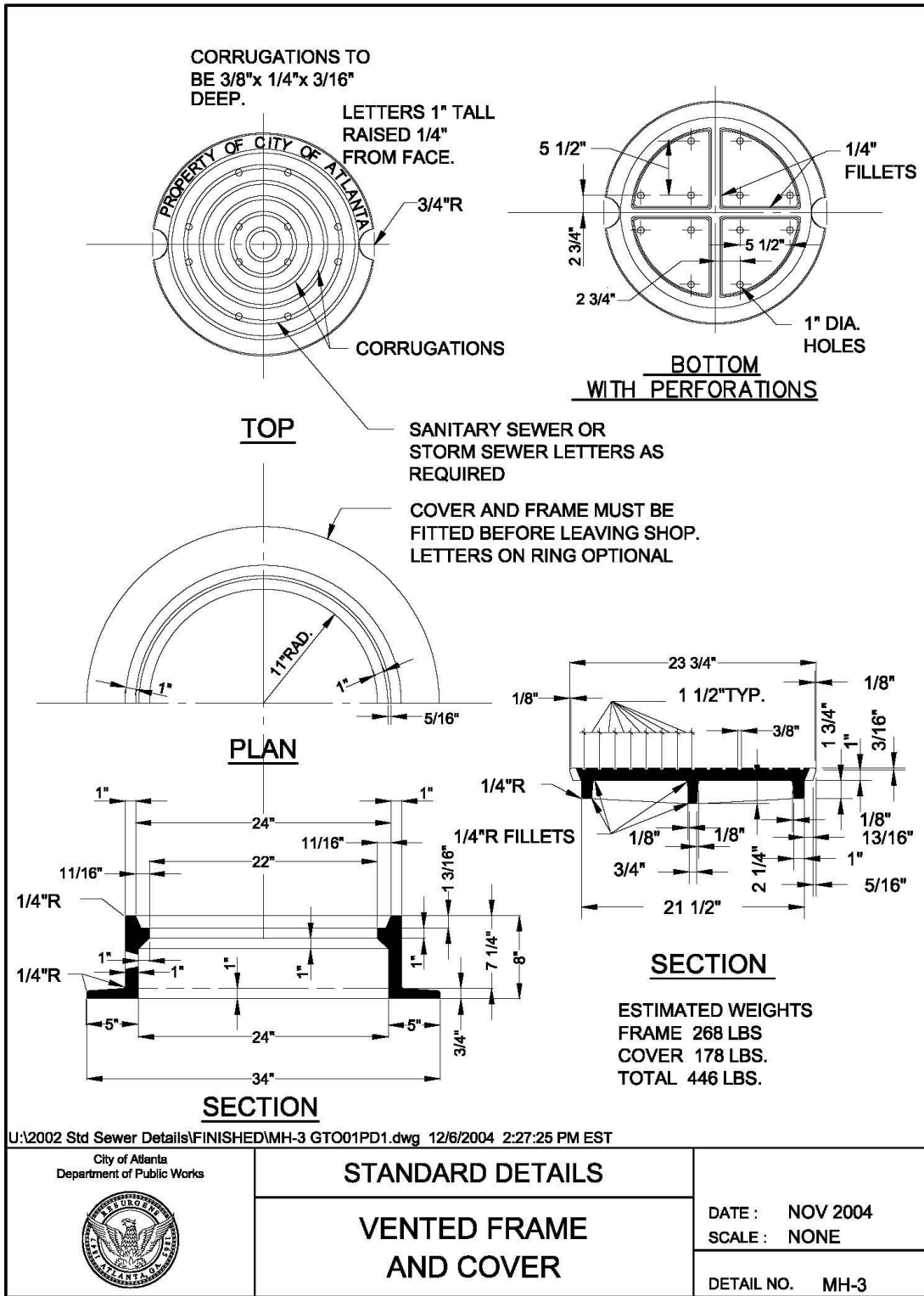

U:\2002 Std Sewer Details\FINISHED\MH-3 GTO01PD1.dwg, 12/18/2004 2:20:28 PM, CutePDF Printer



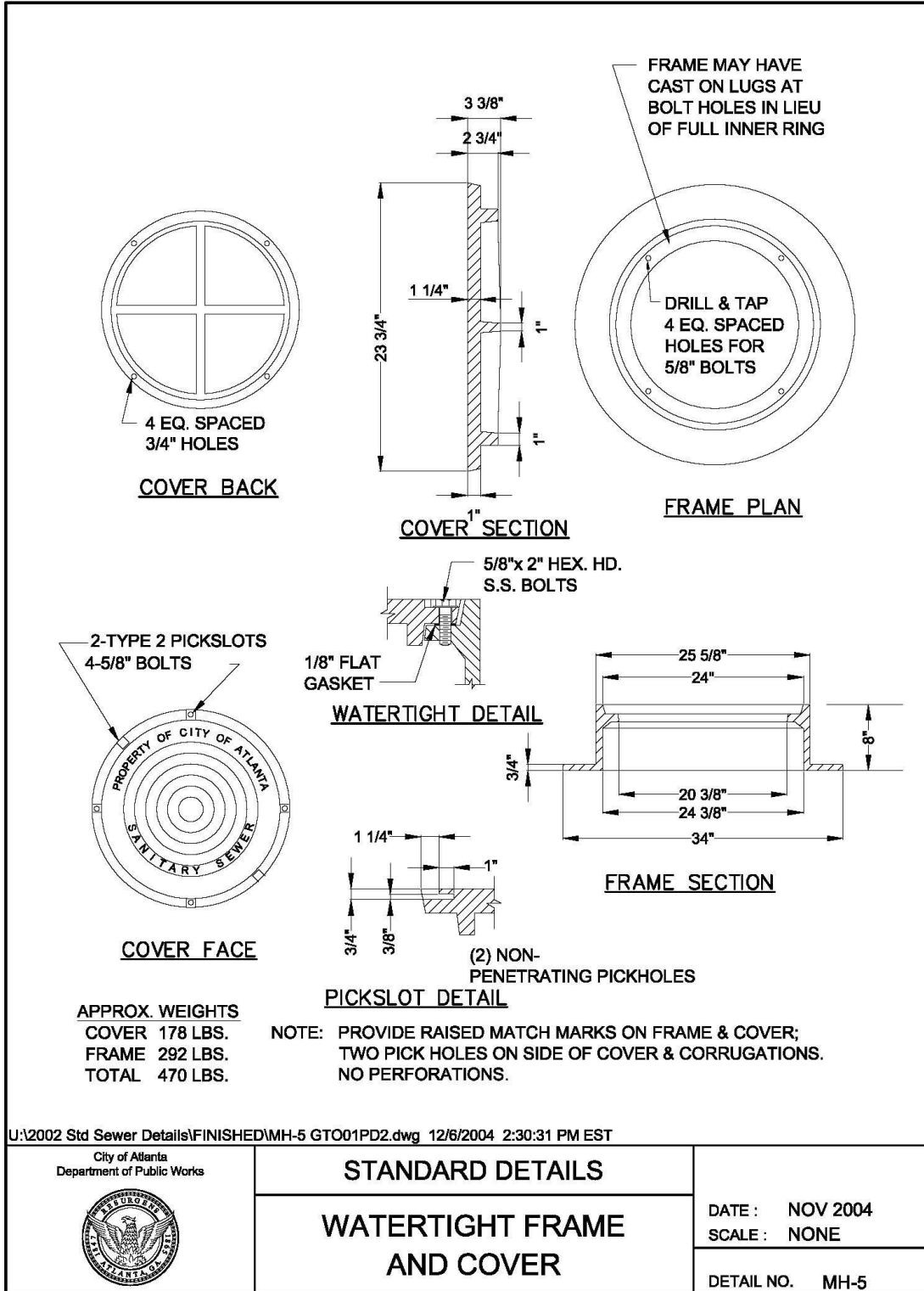

U:\2002 Std Sewer Details\FINISHED\MH-5 GTO01PD2.dwg, 12/18/2004 2:21:57 PM, CuiPDF Printer

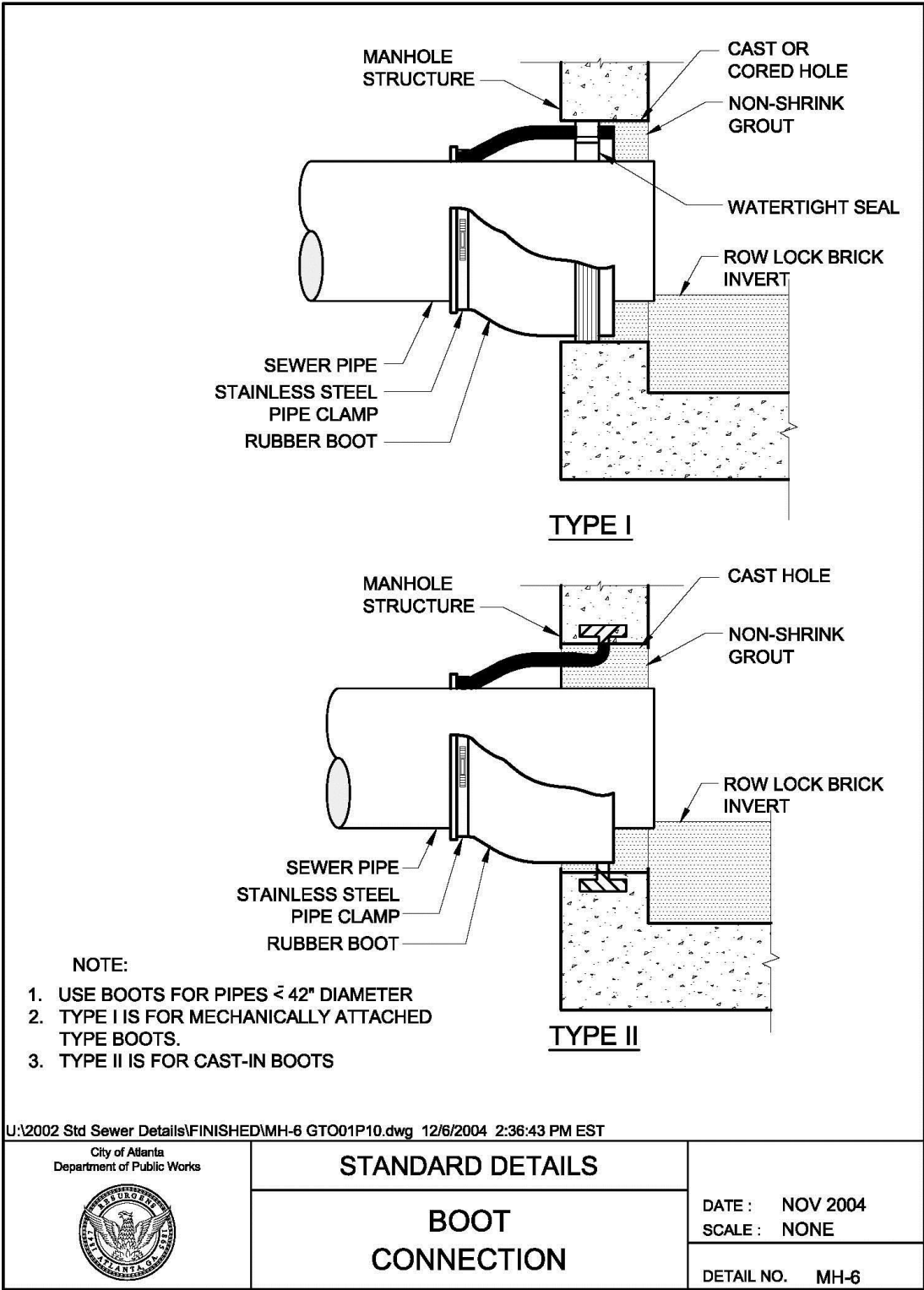

U:\2002 Std Sewer Details\FINISHED\MH-6 GTO01P10.dwg, 12/6/2004 2:22:31 PM, CutePDF Printer

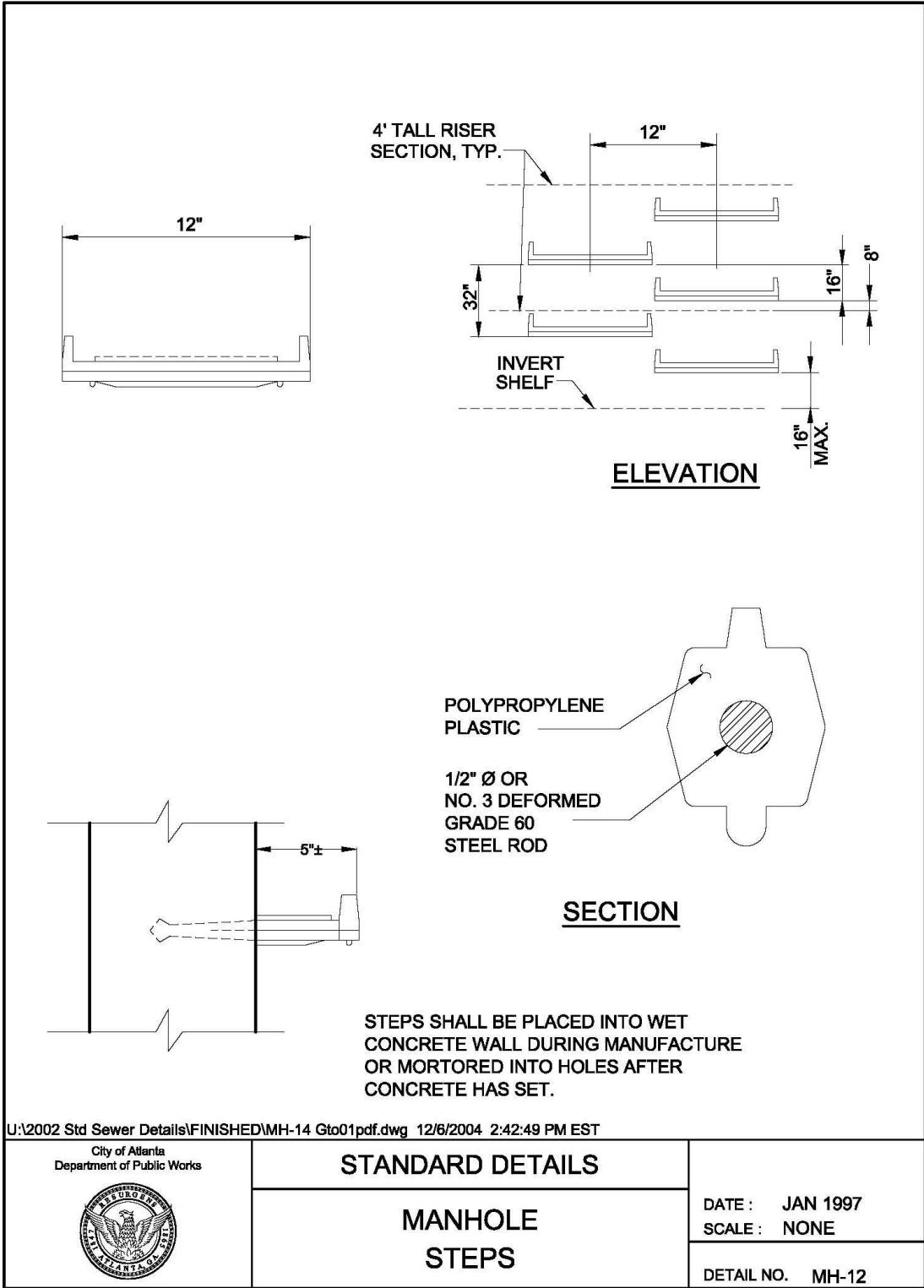

U:\2002 Std Sewer Details\FINISHED\MH-14 Gto01pdf.dwg 12/6/2004 2:30:00 PM, CulePDF Printer

END OF SECTION

---

**SECTION 02511****Preconditioning and Cleaning Manholes and Sewers****PART 1 – GENERAL****1.01 SCOPE**

- A. The objective of preconditioning and cleaning is to maximize sewer and manhole service efficiency and effectiveness. Preconditioning and cleaning involves removal of silt, which is defined as any and all solid or semi-solid materials, including fine and granular material, such as sand, grit, gravel, and rock as well as debris, grease, oil, sludge, slime, or any other loose material or encrustation lodged in the manhole or sewer. Preconditioning and cleaning also involves removal of invading roots, corroded concrete, corroded manhole rungs, corroded ladders, intruding laterals and any other extraneous debris. Two levels of performance concerning preconditioning and cleaning of manholes and sewers shall be adhered to in this contract, as directed:
1. Preconditioning and cleaning as a general level of service; this requires that manholes and sewers shall be considered preconditioned and cleaned if:
    - a. Silt is removed and disposed of to a nominal depth of not more than 10% of the through flow channel in manholes, or sewer between manholes, where the through flow channel or sewer has an equivalent diameter up to and including 24-inches.
    - b. Silt is removed and disposed of to a nominal depth of not more than 5% of the through flow channel in manholes or sewer between manholes, where the through flow channel or sewer has an equivalent diameter greater than 24-inches.
    - c. No surface or appurtenance in manholes including walls, cones, slabs (both intermediate and roof slabs), rungs and benches and drop shafts shall have any remnant of silt, coating, loose bricks, unsound concrete or mortar or loose material.
    - d. All roots, corroded concrete, corroded rungs, corroded ladders and intruding laterals are treated or reduced and cut flush with the interior surface of manholes and sewers, removed and disposed of.

Fulfillment of these requirements (e.g., depth of silt or cleanliness of surface) is to be determined by internal manhole and sewer condition survey or inspection of each manhole and sewer length preconditioned or cleaned as directed.

2. Preconditioning and cleaning prior to rehabilitation and repair; which requires that manholes and sewers shall be considered preconditioned and cleaned if, in addition to the requirements of Section 1.01.A.1 above, all silt has been removed from a minimum of 95% of the through flow channel and sewer cross section. In the case of manholes, all surfaces shall be free of cleaning agents and their reactant products. Fulfillment of these requirements is to be established by internal manhole and sewer condition survey or inspection of each manhole and sewer length preconditioned or cleaned as directed.
  - B. The Contractor shall precondition and clean the manholes and sewers selected by the Engineer or specified herein so as to remove all silt, debris, roots, corroded concrete, corroded rungs and ladders, intruding laterals, etc., and dispose of the material at an approved site.
  - C. During preconditioning and cleaning work and all other associated Contractor operations, sewer services shall be maintained at all times. This requirement may be relaxed only with the written approval of the Engineer.
  - D. The manholes and sewers to be preconditioned and cleaned convey sanitary sewage or combined sewage. In many instances such sewers are subject to high flows, either continuously or in a periodically varying cycle, due to rainfall, infiltration, and/or pumping operations. The Contractor shall include in his bid provisions for dealing with such variations, and where necessary, schedule his Work to accommodate such variation in flows.

## 1.02 RELATED SECTIONS

- A. The Work of the following Sections apply to the Work of this Section. Other Sections of the Specifications, not referenced below, shall also apply to the extent required for proper performance of Work.
  1. Section 02752: Internal Sewer Condition Assessment.

## 1.03 REGULATORY REQUIREMENTS

- A. The Work of this Section shall comply with the current versions, with revisions, of the following: OSHA 29 CFR 1910.146 (permit-required confined-space regulations)

- B. All work and testing shall comply with the applicable Federal codes, including Federal Occupational Safety and Health Act of 1970 and the Construction Safety Act of 1969, as amended, and applicable state and local codes and standards; and to the extent applicable with the requirements of the Underwriter’s Laboratories, Inc. and the National Electric Code.

#### **1.04 EXPERIENCED WORKERS**

- A. All crew chief(s) responsible for preconditioning and cleaning work shall have a minimum of 3 years previous experience in preconditioning, cleaning and related activities including:
1. Use of gas safety monitors/detectors/testers
  2. Safe working in confined spaces
  3. Utilization of hydraulic pressure jetting/water blasting in sewers and confined spaces
  4. Utilization of root cutters and/or root treatment using chemicals
  5. Utilization of a wide range of cleaning nozzles in widely differing conditions
- B. The Contractor shall provide the Engineer with written documentation that all workers on site meet these experience requirements. This documentation shall include a list of projects on which each individual worked and client name and telephone number for each reference.

### **PART 2 – PRODUCTS – NOT USED**

### **PART 3 – EXECUTION OF THE WORK**

#### **3.01 GENERAL**

- A. Preconditioning and cleaning works shall be carried out from the downstream access manhole or chamber to the upstream access manhole or chamber and shall entirely comply with the performance requirements defined in the relevant sub-clause of clause 1.01 above.

#### **3.02 WORKING AREA**

- A. The working area in which machinery and equipment operates is to be kept to a minimum. Equipment not in use shall be removed from the work site so as to minimize disruption to traffic and the general public.



- B. The working area is to be free from silt and debris when the Contractor leaves the site at the end of each visit.
- C. Open manholes, machinery and standing equipment shall be protected at all times.

### **3.03 LOCATION**

- A. The locations of sewers included in the Work are indicated in the Drawings.

### **3.04 TRAFFIC CONTROL**

- A. Refer to Specification Section 01500: Temporary Control of Construction Operations for requirements.

### **3.05 NOISE CONTROL**

- A. All work activities for preconditioning and cleaning sewers and manholes shall comply with the requirements of SC-11.6. The Contractor shall employ the “best practicable means” to minimize and mitigate noise as well as vibration resulting from operations. Mitigation measures shall include the utilization of sound suppression devices on all equipment and machinery particularly in residential areas and in the near vicinity of hospitals and schools, especially at night.

### **3.06 FENCING**

- A. All unattended open manholes and working areas shall be provided with temporary fencing and/or barriers meeting applicable Federal, State, and City of Atlanta standards and subject to the approval of the Engineer.

### **3.07 WORKING HOURS**

- A. Work hours are per the General Conditions of the Contract Agreement. No work shall be carried out at any other time including Saturday, Sunday and holidays without permission in writing from the Engineer except when the work is unavoidable or necessary for the saving of life or protection of property. In such case the Contractor shall immediately notify the Engineer.
- B. Work on principal highways and major roads shall be restricted to certain hours as directed by the Engineer and/or specified herein. The Contractor will be compensated through the appropriate Task Allowance for additional costs incurred when work hours are restricted.

### **3.08 SCHEDULING OF WORK**

- A. After discussion with the Engineer, the Contractor shall prepare and submit a schedule of work that will meet the requirements of the City and the limitations imposed under the Contract Documents. The Contractor shall follow the approved schedule as specified in the General Conditions of the Contract.

### **3.09 PROLONGED ABSENCE FROM SITE**

- A. If the Contractor will be absent from the work site, or part of the work site, for a prolonged period, he shall inform the Engineer, replace manhole covers, and clear any roadways of his equipment and materials, including temporary traffic control measures he may be using.

### **3.10 OPERATIONAL REQUIREMENTS**

- A. Each preconditioning and cleaning unit and each CCTV/sonar unit shall carry sufficient numbers of guides and rollers such that, when cleaning and inspecting or surveying, all bonds (e.g. metal winch cable) are supported away from sewer and manhole structures.
- B. Each preconditioning and cleaning unit shall carry a range of flow control equipment, as opposed to bypass pumping equipment, for use in controlling the flow during the work. A minimum of one item of each size of equipment ranging from 4-inch to 24-inch diameter inclusive shall be carried.
- C. The system of silt and debris removal shall be capable of operating in such a way as to minimize the obstruction to sewer flows and preconditioning and cleaning operations.
- D. Basements, homes and all other vulnerable property shall be prevented from being flooded where hydraulic preconditioning and cleaning methods are used to precondition and clean manholes and sewers.
- E. The Contractor shall make his own arrangements for the secure “off road” overnight parking of his vehicles and cleaning equipment and shall comply with all relevant statutory traffic regulations and local laws.

### **3.11 HANDLING AND DISPOSAL OF REMOVED MATERIAL**

- A. The Contractor shall remove all silt, debris, detritus, etc. resulting from all manhole and sewer preconditioning and cleaning activities at least once each working day. Such material shall be caught and collected in a suitable trap, weir, or dam within the manhole or chamber being preconditioned and cleaned and/or at the downstream manhole of the sewer segment being preconditioned and cleaned. The Contractor shall ensure that the capture

method or methods used effectively prevent silt migration downstream. Descriptions of such methods, including details of the equipment used, shall be provided to the Engineer on request.

- B. All material removed from sewers and manholes shall be deposited in suitable closed watertight containers such that the total amount removed can be easily measured if required. The Contractor is to give the Engineer such assistance as may be necessary in carrying out this measurement work.
- C. The type and capacity of containers to be employed for the holding and transport of the removed materials shall be determined by the Contractor. The Contractor shall not accumulate or store debris, silt, and/or liquid waste or sludge on site. Under no circumstances shall sewage, silt or solids be dumped onto the ground surface, ditches, catch basins or storm drains.
- D. The Contractor's work procedures shall be such that sewer preconditioning and cleaning work is not delayed by a lack of an empty container in which to deposit the materials removed from the sewer.
- E. The Contractor is advised that it may not always be possible for the container to be positioned immediately adjacent to the manhole from which materials are being removed and that "double handling" of the materials may be necessary. The Contractor shall provide for such "double handling" to be carried out safely and efficiently at no additional cost to the City.
- F. The Contractor must make his own arrangements for the proper disposal of materials removed from the sewer. The disposal site must be licensed to accept such materials and must be approved by the Engineer prior to commencement of the work. The Contractor shall be responsible for obtaining all necessary disposal permits and for complying with all state and City regulations for handling silt laden sewage.
- G. All costs associated with disposal permitting and silt handling must be included in the Contractor's rates for work.
- H. The containers for the disposal of materials removed from sewers and manholes shall be routed through an approved weigh station and a copy of each weight ticket submitted to the Engineer. Such tickets shall be used to determine the quantities of materials removed.

### 3.12 WATER SUPPLY

- A. Prior to the commencement of work, the Contractor shall locate all hydrants from which water may be obtained.
- B. The Contractor is responsible for making his own arrangements for obtaining water for the work, and he shall comply with all local conditions regarding the use of construction and flushing water. Such arrangements shall be approved by the Engineer prior to commencement of work.
- C. All details of the point of water connection, backflow protection, conveyance methods, draw-off rates, times and all local conditions regarding the use of water shall be approved by the Engineer prior to commencement of work. All equipment, labor, and material required for obtaining water for the work shall be provided by the Contractor.
- D. The Contractor shall provide constant attendance when water is being drawn off any hydrant.
- E. The Contractor must ensure that a 12-inch minimum air gap is maintained at the supply point on desilting/cleaning/jetting equipment or any other receiving apparatus.
- F. The use of any standpipe or hydrant, which has not been approved by the Engineer, is expressly forbidden.

### 3.13 TRAVEL

- A. The cost of all travel required in the completion of the specified work shall be included in the Contractor's rates for work.
- B. The cost of travel required for the completion of extra work for which unit costs are not included in the Contract shall be at rates documented in writing by the Contractor.

### 3.14 SUPERVISION

- A. A responsible representative of the Contractor shall be present on the site of the work, or other location approved by the Engineer, to provide supervision of the work. At all times, and especially when a change of work location is underway, the Contractor's representative shall keep the Engineer continuously aware of the location, progress, planned execution of the work, and problems encountered.

### **3.15 COMMUNICATION**

- A. The Contractor's on-site representative directly responsible for the work shall be immediately reachable at any time during the normal working day and shall immediately respond to all questions and directions by the Engineer.
- B. Adequate means of communication by telephone, portable radio, or other electronic means of communication must be maintained at all times as part of the routine work methodology and in case of an emergency, between all points of activity along the length of the sewer being preconditioned and cleaned.

### **3.16 DAMAGE TO MANHOLES OR SEWERS CAUSED BY CONTRACTOR**

- A. The Contractor shall use special care in his work methods and take all necessary precautions against improper use of the preconditioning and cleaning equipment to avoid damaging the sewer and/or manholes being preconditioned and cleaned. If in the Engineer's opinion, the Contractor's work has caused damage to the manhole or sewer, the Contractor shall repair the damage to the complete satisfaction of the Engineer at no additional cost to the City.

### **3.17 RESPONSIBILITY FOR OVERFLOWS OR SPILLS**

- A. It shall be the responsibility of the Contractor to schedule and perform his Work in a manner that does not cause or contribute to incidence of overflows or spills of sewage from the sewer system.
- B. In the event that the Contractor Work activities contribute to overflows or spills, the Contractor shall immediately take appropriate action to contain and stop the overflow, clean up the spillage, disinfect the area affected by the spill, and notify the designated Engineer in a timely manner, all in accordance with the City's Emergency Response Plan.
- C. Contractor will indemnify and hold harmless the City for any fines or third-party claims for personal or property damage arising out of a spill or overflow that is fully or partially the responsibility of the Contractor, including the legal, engineering and administrative expenses of the City in defending such fines and claims

**PART 4A – GENERAL TECHNICAL EQUIPMENT SPECIFICATION - SEWERS****4A.01 GENERAL**

- A. The Contractor shall certify that sufficient cleaning units can be provided, including standby units in the event of breakdown, in order to complete the work within the contract period. Further, the Contractor shall certify that standby or back-up equipment can be delivered to the site within 48 hours in the event of equipment breakdown.
- B. The cleaning unit(s) shall be capable of operating routinely, up to a minimum of 500-feet from the point of access to the sewer.
- C. Each cleaning unit shall carry a mobile telephone to facilitate communication with the Engineer and to comply with relevant safety requirements defined in the safe working procedures approved by the Engineer for the execution of the work.

**4A.02 CCTV AND SONAR INSPECTION/SURVEY UNITS**

- A. All CCTV and sonar survey units shall comply with Specification Section 02752 unless otherwise determined.

**4A.03 WINCHING EQUIPMENT**

- A. Winching equipment shall be sufficient for the purposes of attaining the degree of cleanliness specified in Section 1.01A
- B. The Contractor shall provide conventional power winching equipment and all associated equipment, including winching buckets, balls, breakers, kites, scooters, scrapers, tires, tools and safety apparatus. Complete details of equipment proposed for use in preconditioning and cleaning shall be provided to the Engineer before work commences.
- C. Dredging of sewers shall be undertaken by passing various sized buckets, balls, breakers, kites, scooters, scrapers, tires etc, through the sewers to physically remove accumulated silt, sludge and other debris. Where conditions dictate, power boring equipment and/or winching equipment shall be used to loosen the silt prior to its removal. All necessary equipment including cables, lines, and tools must be available at all times as required.
- D. The equipment shall be capable of operating efficiently and effectively in the sizes of sewers and depth included in the project at distances of up to 500-feet between adjacent manholes.
- E. The project sewers convey sanitary sewage, storm water, or combined sewage flows. Certain Sections of sewer may be flowing entirely full or in a

surcharged condition and the Contractor must be prepared at all times to use manual pushing rods, mechanical boring equipment or other methods to pass a leading line through the sewer prior to commencing dredging operations with winching.

- F. Any item of CONTRACTOR plant or equipment associated with the Work, which may cause obstruction to the flow in the sewer, shall be removed from the sewer at the close of work each day. It shall be permitted to leave a line or winching cable through the sewer during breaks in the work.
- G. Dredging operations in a particular Section of sewer will generally proceed in a downstream direction, working between consecutive manholes using winch buckets of sizes stated below.
- H. The size of winch bucket used in sewers up to 48" shall be 90% of the sewer bore up to a maximum of 24". It is anticipated that buckets of smaller sizes than those stated will need to be winched through Sections of sewer prior to the use of the maximum sizes. The maximum size bucket as stated may be varied at the discretion of the Engineer. However, no buckets larger than these maximum sizes specified shall be used without the approval of the Engineer.
- I. The Contractor is advised that use of the maximum size buckets listed above may not be practical due to restricted access through manhole covers and other access points. The Contractor shall ensure that his working procedures will not be unduly affected by such restrictions and shall allow for inefficiencies due to all such restrictions in his unit rates.
- J. The winches used to draw buckets, balls, breakers, scooters, scrapers, or tires shall be power driven. They shall incorporate a torque-limiting device to prevent the breaking of winching lines in case the line becomes jammed by obstructions.
- K. Where the operational cleaning equipment is towed by winch and bond through the sewer, all winches shall be stable with either lockable or ratcheted drums. All bonds shall be steel or of an equally non-elastic material to ensure the smooth and steady progress of the equipment. All winches shall be inherently stable under loaded conditions.

#### **4A.04 PRESSURE JETTING EQUIPMENT**

- A. Pressure jetting equipment used shall be sufficient for the purposes of attaining the degree of cleanliness in sewers and manholes as specified in Section 1.01.

- B. Jetting units in sewers must be capable of jetting a minimum distance of 500-feet either upstream or downstream from a manhole. Minimum nominal hose size shall be one-inch diameter.
- C. The Contractor's unit prices specified in the bid form shall include jetting in sewers both upstream and downstream.
- D. Successive passes using constantly moving pressure jetting techniques shall be applied to sewers until they are cleaned to the level specified. Nozzle hold-time (stationary time), for any particular location, shall not be more than 60 seconds in order to forestall damage to the pipe being cleaned. Nozzles shall have jet angles of between 30° to 45°. “High efficiency nozzles” (discharging “pencil jets”) with jet angles higher than this figure shall not be allowed to be stationary at any time.
- E. Silt shall be collected at manholes as specified herein. No silt shall be allowed to pass beyond the Section of sewer being cleaned.
- F. Pass rates (rewind speed) for the jetting head shall be at a consistent speed without jerking and excessive variations. Typical pass rates shall be 4 inches to 8 inches per second. The hose reel shall be power driven in the rewind direction.
- G. Manual pressure jetting within manholes shall not be allowed. Progress towards the desired level of service specified in manholes may be monitored by a stem linked TV camera. Manhole pressure jetting for the purpose of cleaning or preconditioning shall be executed either:
  - 1. Manually from the ground surface, or
  - 2. Robotically within the manhole
- H. The Engineer shall be notified of the jetting equipment proposed by the Contractor in the bid documents. The jetting equipment will be operated utilizing the pressures specified unless otherwise noted elsewhere in the document. The proposed equipment shall be categorized from the following table:



**TABLE 4.4.1**

CATEGORY	MACHINE TYPE	CAPACITY (GALL/MINUTE)		PRESSURE (p.s.i.)	
		min	max	min	max
<b><u>Manholes</u></b>					
1	High pressure/low volume – trailers	1	35	3,000	10,000
2	<b>High pressure/low volume – mini</b>	9	35	3,000	10,000
3	High pressure/low volume – non HGV/HGV jetter/combination	9	35	3,000	5,000
<b><u>Sewers</u></b>					
4	Low pressure/high volume – HGV	30	50	1,500	2,000
5	Low pressure/high volume – combination	30	75	1,500	3,000
6	Low pressure/high volume – super combination	75	175	2,000	2,500
7	Low pressure/high volume – separate jumbo jetter/suction units	75	200	2,000	2,500
<b><u>Other</u></b>					

Notes for Table 4.4.1

1. The categories listed are typical only of the equipment for use in the present contract. Exceptions to the duty and equipment shown above will be allowed subject to appropriate notification and approval. The Contractor is required to complete the table with details of any other equipment proposed.
2. Discretion shall be used concerning the maximum pressure used for cleaning sewers. In general for asbestos cement, clay and concrete pipes cleaning pressures shall be limited to 5000 psi (340 bar). For brick sewers cleaning pressures shall be limited to 3500 psi (240 bar) For pitch fiber and plastic pipes cleaning pressures will be limited to 1500 psi (102 bar) and 2500 psi (170 bar) respectively.
3. Cleaning pressures in concrete manholes shall be limited to 5000 psi (340 bar). Cleaning pressures in new brickwork manholes shall be limited to 5000 psi (340 bar) and in old brickwork manholes to 3500 psi (240 bar).

4. Higher pre-conditioning pressures in sewers and manholes prior to rehabilitation may be allowed at the sole discretion of the Engineer. The Engineer's agreement to use higher pressures shall not relieve the Contractor of his responsibilities for any resultant damage in accordance with the requirements of paragraph 3.16 above.
  - I. Where a jetter is fitted with an airflow suction unit for removal of silt and other material from the sewer, it shall be capable of removing materials such as sludge, silt and bricks from depths up to 32-feet with minimum suction of 2500-cfm. A tank with a minimum capacity of 175-cf shall be provided and be capable of decanting collected liquids and conveying them back to the sewer. The suction hose of such a system shall have a minimum internal diameter of 6-inches.
  - J. Jetting equipment shall be calibrated on an annual basis by an approved body and calibration certificates made available for inspection by the Engineer as requested. Such equipment shall be maintained on a regular basis in accordance with the manufacturer's Specification. The Contractor shall make available copies of his maintenance certificates and/or schedules to the Engineer as requested.
  - K. An automatic pressure relief valve shall be incorporated on the pump discharge chamber to prevent the pressure exceeding the safe maximum for the system as a whole. This may take the form of a pressure relief valve of the bursting disc type in holder or an automatic pressure regulating valve (unloading valve).

**NOTE:** The maximum working pressure is the lowest value of the maximum working pressure ratings of all individual components of the system.

#### **4A.05 AIR DRIVEN, ELECTRO-MECHANICAL AND/OR MECHANICAL PRE-CONDITIONING AND CLEANING TOOLS**

- A. Where necessary, and additional to winching and pressure cleaning equipment, appropriate air driven, electrically driven and/or mechanical tools may be used to needle, hammer, scrape or grind off corroded concrete, scarify and remove compacted silt, chip-off spilt grout, detach encrustation, trim and cut laterals and roots, etc. The Contractor shall provide prior notification to the Engineer prior to the use of such equipment and techniques.

#### **4A.06 VENTILATION OF CONFINED SPACES**

- A. The Contractor shall provide, operate, maintain and subsequently remove on completion, adequate ventilation apparatus in the form of blowers

and/or fans. The ventilation apparatus shall introduce a fresh air supply to support a safe environment for work in sewers, manholes and all other confined spaces, which shall be kept free from dangerous, toxic and/or explosive gases, whether generated from sewage, soil strata or other source.

## **PART 4B – GENERAL TECHNICAL EQUIPMENT SPECIFICATION - MANHOLES**

### **4B.01 PRECONDITIONING AND CLEANING AS A GENERAL LEVEL OF SERVICE**

- A. With the exception of the “through flow” channel, all surfaces shall be thoroughly cleaned using high pressure water with sufficient pressure (minimum force of 3500 psi.(240 bar)) to achieve the specified level of preparation. Preconditioning and cleaning shall include the removal of all roots, corroded concrete, corroded rungs, intruding laterals and any other extraneous, loose material, debris or foreign matter using air driven, electrically driven or mechanical equipment as specified.
- B. Before preconditioning and cleaning work commences, silt, sand and debris traps shall be installed at the entrance to the downstream sewer to capture all silt and debris material.

### **4B.02 PRECONDITIONING AND CLEANING PRIOR TO REHABILITATION AND REPAIR**

- A. All concrete and masonry surfaces to be rehabilitated or repaired shall be meticulously cleaned by water blasting utilizing a 210°F steam unit and appropriate nozzles to provide a contamination-free and sound surface. Other methods, such as wet or dry sand blasting, acid wash, concrete cleansers, degreasers or mechanical means, may be required to completely clean the manhole surface prior to rehabilitation or repair.
- B. All surfaces on which preconditioning and cleaning methods outlined in Paragraph 4B.02.A above have been used shall be thoroughly rinsed, scrubbed, and neutralized to remove cleaning agents and their reactant products before rehabilitation commences. Concrete surfaces shall be accepted for the purpose of rehabilitation when they are sound, surface dry, porous and free from dust, dirt, oil, grease, fat efflorescence, concrete hardening or sealing chemicals, previous coatings, rust, form-release agents, laitance, other penetrating contaminants, fins, surface projections, thin crusts, bridging voids, and loosely adhering concrete and dirt particles.
- C. All manhole “runner” and “gusher” infiltration leaks shall be sealed in areas where linings are to be installed. The Contractor will not be allowed to commence rehabilitation work until these leaks have been sealed to the satisfaction of the Engineer.

- D. Where required by the relevant manhole rehabilitation system, manhole surfaces to be rehabilitated shall have a pH of 7 to 10. Surfaces shall be tested in accordance with ASTM D4262.
- E. Where instructed by the Engineer, the Contractor shall test prepared surfaces by Swiss impact hammer or other physical method to determine soundness.

## PART 5 – QUALITY CONTROL/PRECONDITIONING AND CLEANING REPORT

### 5.01 GENERAL

- A. A quality control video inspection of preconditioned and cleaned sewers shall be carried out as directed, immediately following completion of preconditioning and cleaning work. If a sewer or pipe line has not been preconditioned or cleaned as specified (by visual inspection, video review or field analysis) in the sole opinion of the Engineer, the sewer shall be re-preconditioned and cleaned in accordance with the Specification at no additional cost to the City.
- B. The Contractor shall supply one copy of inspection video for each reach of sewer completed.
- C. When required by the Engineer, the Contractor shall supply one copy of the full internal sewer condition assessment report, completed in accordance with the requirements of Specification Section 02752. This Specification includes a sample report sheet also reproduced at the end of this Specification. The sample report sheet shall be accurately and fully adopted in format and in detail and submitted by the Contractor immediately following the QA/QC inspection.

### 5.02 DAILY LOG

- A. The Contractor shall provide a report of work completed each day. The report shall be submitted to the Engineer no later than one workday following completion of the work. The report shall contain a separate sheet for each manhole and sewer reach preconditioned. The report shall utilize the form provided at the end of this Specification.
- B. The Contractor shall immediately notify the Engineer of any material such as bricks, concrete or broken clay pipe appearing in the materials removed from the sewers and/or manholes during preconditioning and cleaning activities.

**(EXAMPLE)**  
**CONFINED ENTRY LOG**  
**MANHOLE/ SEWER SAFETY CHECK**  
 (TO BE COMPLETED DAILY)

Date: \_\_\_\_\_ Supervisor: \_\_\_\_\_ Vehicle No. \_\_\_\_\_

Time	Manhole No.	Manhole Location
1.		
2.		
3.		
4.		
5.		

Workers on site: \_\_\_\_\_  
 (Underline those with safety training certification)

**Safety Apparatus on Site:** (tick)

- |   |  |  |
|---|--|--|
| Multi Gas Monitor <input type="checkbox"/>    | Lifting Harness <input type="checkbox"/> | Lifeline <input type="checkbox"/>            |
| Helmet/ Safety Boots <input type="checkbox"/> | First Aid Kit <input type="checkbox"/>   | Torch Light <input type="checkbox"/>         |
| Aluminum Ladder (AL) <input type="checkbox"/> | Air Blower <input type="checkbox"/>      | Breathing Apparatus <input type="checkbox"/> |
| Headphone <input type="checkbox"/>            | Cell Phone <input type="checkbox"/>      |  |

**Safety Check:** (tick)

- |  |  |
|--|--|
| Manhole Vented by Blower? <input type="checkbox"/>   | Manhole Tested for Gases? <input type="checkbox"/>                                     |
| Oxygen Sufficiency OK? <input type="checkbox"/>      | Protective Clothing Worn? <input type="checkbox"/>                                     |
| Top Men Carrying BA? <input type="checkbox"/>        | Ladder Used <input type="checkbox"/>   |
| Traffic Signs and Cones OK? <input type="checkbox"/> | Blinkers and Beacons OK? <input type="checkbox"/> Site Plans? <input type="checkbox"/> |

**Gas Monitoring Readings**

Time	Hydrogen Sulfide Level		Oxygen Level %	Carbon Monoxide Level		Methane Level	
	Detected (PPM)	Not Detected		Detected (PPM)	Not Detected	Detected (PPM)	Not Detected

Manhole/ Sewer Safe to Enter?  Yes  No  Incidents, if any: \_\_\_\_\_  
 (Append Lengthy Description)  
 Signature of Safety Officer/ Supervisor: \_\_\_\_\_ Date: \_\_\_\_\_

**PRECONDITIONING & CLEANING REPORT SHEET FORM 'A'**  
(TO BE COMPLETED DAILY)

Date \_\_\_\_\_  
Crew \_\_\_\_\_  
Site \_\_\_\_\_

Sheet \_\_\_\_ of \_\_\_\_  
Time of Arrival \_\_\_\_\_  
Time of Departure \_\_\_\_\_

Location (Street No., Easement Site)	U/S Manhole (Ref)	D/S Manhole (Ref)	Sewer Length (feet)	Unit Highway (Yes/No)	in Sewer Material	Silt Depths @Manholes (inches)	Sewer Size (inches )	Length Cleaned (feet)	Upstream/ Downstream (U/S-D/S)	Comments
<b>Typical Comments (Initial)</b>	Emergency <b>(**EM**)</b>	Urgent Repair <b>(*UR*)</b>	Bad Joints <b>(BJ)</b>	Excessive Silt/Grease <b>(DES/DEG)</b>	Intense Odor <b>(O)</b>	Concrete Debris <b>(DECO)</b>	Roots (Size) <b>(R)</b>	High Levels <b>(HWL)</b>	Clayware Debris <b>(DEC)</b>	Number of Intruding Laterals (Size) <b>(CNI)</b>

Note: Continue on next line where extensive comments or space is required

Signed \_\_\_\_\_  
(Engineers Representative)

Signed \_\_\_\_\_  
(Contractors Representative)

END OF SECTION

(This page is intentionally blank)

---

**SECTION 02725****Pipe-Bursting Method****PART 1 – GENERAL****1.01 SCOPE**

- A. This specification shall cover the rehabilitation of existing, gravity sanitary sewers and sewer service laterals. Acceptable pipe-bursting methods shall include pneumatic, static, push-pull (rod type) and TIM™. All work shall be performed only as directed by the Engineer or shown on the task order Drawings.
- B. Pipebursting is a procedure which encompasses a variety of equipment systems which commonly utilize a burster unit or expander to split the existing pipe while simultaneously pulling a new pipe into place. Acceptable pipe-bursting systems which are commonly used for gravity sewers utilize pneumatic and static type bursting units for installation of a continuous high density polyethylene (HDPE) pipe material between manholes. Other types of pipe-bursting systems are utilized to install segmented non-continuous ductile iron pipe are referred to as static push-pull or TIM™. The new pipe may be of the same size or larger size.
- C. The scope of work requires the Contractor to provide all materials, labor, equipment, and services necessary for bypass pumping and/or diversion of sewage flows, rehabilitation of existing sanitary sewers by bursting the existing pipe and inserting a new pipe, reconnection of active sewer service connections (service laterals), anchoring new pipe, restoring affected manholes, cleaning, CCTV inspection and final testing of the new pipe system.
- D. Pipe-bursting with new HDPE: Pneumatic or static pipe-bursting equipment systems are acceptable for installation of HDPE sewer piping. Pipe-bursting equipment shall be provided with either front or rear expanders for the proper connection to the polyethylene pipe. Pneumatic bursters must be used in conjunction with a constant tension hydraulic twin capstain winch; the size of the winch depends on the diameter of the pipe to be replaced. In no case is the constant tension on the winch to exceed 20 tons. Static bursters shall be equipped with blades or slitters for bursting existing ductile or cast iron pipe.
- E. Static Push-Pull Pipe-Bursting with new DIP: Acceptable push-pull pipe-bursting equipment systems shall utilize a hydraulic jack positioned in the retrieval pit along the existing pipe vertical and horizontal centerline which is used to install bursting rods through the existing pipe to the launch pit. The bursting head and expander shall be connected to the leading



bursting rod then retracted through the host pipe as each new pipe segment is connected at the launch pit. The rods shall be typically removed as they are retracted to facilitate installation of the new piping to the retrieval pit. Restrained joint piping shall be provided for all push-pull pipe-bursting installations where new DIP is directed by the Engineer or shown on the task order Drawings. Acceptable equipment systems are equal to Grundoburst® by TT Technologies, Inc. or Hydroburst™ by EarthTool Company, LLC.

- F. Tenbusch Insertion Method (TIM™) pipe-bursting with new DIP: This technique of pipe jacking may also be used for installation of new DIP. This type of equipment system utilizes the columnar strength of a segmented bell-less jacking pipe to advance the lead train through the existing pipe. The new pipe is to be jacked behind the lead train piece by piece by the jacking frame (in the work pit). The primary jacking frame shall apply the required thrust to advance the new pipe column (as the front jack is retracted). The pipe adapter section shall be fitted with a lubricant injection port where lubricant (polymer or bentonite) can be injected into the annular space surrounding the new replacement pipe as the pipe advances.
- G. The sewer replacement work details include:
1. Site Planning and Preparation:
    - a. Perform site investigation and record all pre-existing conditions of all structures within the immediate area, landscaping and/ or roadways prior to construction.
    - b. Perform initial CCTV inspection of sewer to be replaced (See Section 02752). Locate all active sewer service connections (laterals) and sags or blockages.
    - c. Formulate and execute plans for sag/blockage repairs, launching pipe excavation, layout for sewer bypass pumping system, marking existing utilities, service laterals, cleanout, etc.
  2. Pipe Installation:
    - a. If directed to do so by the Engineer, install cleanout at edge of property line or easement line for pipe-bursting.
    - b. Excavate launching and receiving pits.
    - c. Install sewer bypass pumping system.

- d. Excavate to relieve effects to existing utilities.
- e. Excavate to expose all active service connections (laterals).
- f. If directed to do so by the Engineer, provide bypass pump to extract flow from high-volume service connections (laterals).
- g. If directed to do so by the Engineer, temporarily disconnect/plug active service connections (laterals).
- h. Install new sewer pipeline by pipe-bursting methods.
- i. Install new manholes where required by the Engineer.
- j. Anchor pipe and seal manholes.
- k. If directed to do so by the Engineer, replace existing active service connections (laterals) from new or existing cleanouts and lamp holes to new sewer pipeline.
- l. Perform CCTV inspection of all active service laterals and remedy those determined to be defective.
- m. Reconnect all active service connections (laterals) to new sewer pipeline.
- n. Connect replacement pipeline to existing manholes. (See Section 02491)
- o. Perform post-installation cleaning and CCTV sewer inspection for quality control. (See Sections 02511 and 02752)
- p. Remove sewage bypass pumping system(s).
- q. Backfill and restore excavations. (See Section 02200)
- r. Perform pipeline testing. (See Section 02730)

Note that the items 1b, 2a, 2b, 2c, 2i, 2k, 2l and 2m above are paid for in other bid items. No other additional cost will be paid to the Contractor.

3. Cleanup and restore existing surface condition and structures.
4. Repair defective work per Engineer's final inspection.

- H. The Contractor is responsible for proper and accurate installation of the new sewer pipe regardless of the method described in this section and the following subsections. The Contractor shall ensure that the new pipe's vertical and horizontal alignment is as indicated on the plans and/or as existing in the field in accordance with these specifications.
- I. Supplying all labor, materials, equipment and apparatus not specifically mentioned herewith or noted on the plans, but which are incidental and necessary to complete the Work specified.

## 1.02 QUALIFICATIONS

- A. The Contractor shall be certified by the pipe-bursting system manufacturer as a fully trained and/or licensed user of the pipe-bursting system. Operation of the system shall be performed by trained personnel. Such training shall be conducted by a qualified representative of the system manufacturer.
- B. Polyethylene pipe jointing shall be performed by personnel trained in the use of butt-fusion equipment and recommended methods for new pipe connections. Personnel directly involved with installing the new pipe shall receive training in the proper methods for handling and installing the polyethylene pipe. Training shall be performed by a qualified representative of the fusion equipment manufacturer.
- C. Contractor shall hold the City and Engineer harmless in any legal action resulting from patent infringements.

## 1.03 STANDARD SPECIFICATIONS

- A. Except as otherwise indicated, the current editions of the following apply to the Work of this Section:
  - 1. ASTM D 1599 Test for Short Term Rupture Strength of Plastic Pipe, Tubing and Fittings
  - 2. ASTM D 1928 Preparation of Compression Molded Test Polyethylene Samples
  - 3. ASTM D 2122 Determining Dimensions of Thermoplastic Pipe and Fittings
  - 4. ASTM D 2321 Underground Installation of Thermoplastic Flexible Sewer Pipe

5. ASTM D 2412 External Loading Characteristics of Plastic Pipe by Parallel Plate Loading
6. ASTM D 2657 Practice for Heat-Joining Polyolefin Pipe and Fittings
7. ASTM D 3035 Specification for Polyethylene (PE) Plastic Pipe (DR\_DR) Based on Controlled Outside Diameter
8. ASTM D 3261 Specification for Polyethylene Plastic Pipe and Fittings Material
9. ASTM D 3550 Standard Practice for Ring Lined Barrel Sampling of Soils
10. ASTM F 477 Elastomeric Gaskets (Seals) for Joining Plastic Pipe
11. ASTM F 714 Specification for Polyethylene (PE) Plastic Pipe (SDR-PR) Based on Outside Diameter (3.5" and larger)
12. AWS D1.1 AWS Standard Qualification Procedure
13. ASTM C 12 Standard Practice for Installing Vitrified Clay Pipe Lines
14. ASTM C 1208 Standard Specification for Vitrified Clay Pipe and Joints for Use in Jacking, Sliplining and Tunnels
15. ASTM C 828 Standard Test Method for Low Pressure Air Test of Vitrified Clay Pipe Lines
16. ASTM C 1091 Standard Test Method for Hydrostatic Infiltration and Exfiltration Testing of Vitrified Clay Pipe Lines
17. ASTM C 425 Standard Specification for Compression Joints for Vitrified Clay Pipe and Fittings
18. ASTM C 700 Standard Specification for Vitrified Clay Pipe, Extra Strength, Standard Strength and Perforated
19. ASTM C301 Standard Test Methods for Vitrified Clay Pipe

## 1.04 RELATED SECTIONS

- A. The Work of the following Sections applies to the Work of this Section. Other Sections of the Specifications, not referenced below, shall also apply to the extent required for proper performance of Work.
1. Section 02511: Preconditioning and Cleaning Manholes and Sewers
  2. Section 02750: Wastewater Flow Control
  3. Section 02200: Earthwork
  4. Section 02730: Sewers and Accessories
  5. Section 02140: Dewatering

## 1.05 SUBMITTALS

- A. The following shall be submitted to the City in writing prior to or at the time indicated in accordance with General Condition Section 28. Failure to do so will prevent progression of the Work to the next stage:
1. Manufacturer's technical literature on the proposed pipe-bursting systems **(At Pre-Construction Meeting)**
  - 2.
  3. Written certification from the pipe-bursting system provider that the Contractor or Subcontractor is a trained and licensed installer **(At Pre-Construction Meeting)**
  4. Shop drawings, catalog data, and manufacturer's technical data showing complete information on material composition, physical properties, and dimensions of new pipe and fittings. Include manufacturer's recommendations for handling, storage, time for re-connection of laterals, joint welding and repair of pipe and fittings damaged **(At Pre-Construction Meeting)**.
  5. The Contractor shall prepare and submit, for the Engineer's approval, a general methodology of the Bursting Plan, including materials and equipment, lateral numeration and manhole restoration procedure and materials, by-pass pumping system accommodation and maintenance of intermediate flows and connections, plan of operation, construction and restoration of

existing sewer service connections **(At Pre-Construction Meeting)**.

6. The Contractor shall prepare and submit, for the Engineer's approval, a general methodology for dealing with possible ground heave shall be fully detailed both in relation to:
  - a. Restoration of Landscape areas-restoration of ground contours and surface treatment to meet the reasonable requirements of the property owner, and
  - b. Structures: Pre-installation of monitoring devices where the adverse effect of pipe bursting could worsen existing structural defects in buildings and/or other structures. **(At Pre-Construction Meeting)**
7. Certification of workers trained for welding and/or installing pipe **(At Pre-Construction Meeting)**.
8. Static Push-Pull Pipe bursting or TIM™: Submittals shall include shop drawings and calculation of columnar strength of the pipe. The drawings shall show dimensions of pipes including inside diameter and wall thickness, details of pipe joints and gaskets showing cushion packing ring (if required) and laying length of each pipe. **(30 Calendar Days before Bursting)**
9. Pre installation CCTV inspection reports and videos. Pre installation reports and videos shall be provided no later than 30 calendar days before pipe-bursting **(30 Calendar Days before Bursting)**.
10. Manhole invert rebuilding method and materials **(30 Calendar Days before Bursting)**
11. A detailed methodology for each set up during the course of the contract, but not less than ten days before bursting is planned to commence. This detailed methodology shall be agreed upon between the contractor and the Engineer. **(10 Calendar Days before Bursting)**
12. Drawings and design calculations demonstrating adequacy of any proposed temporary work including excavation, locations, sheeting and shoring, method of dewatering, other utilities that may be affected; width and length of working area access pit and portions of existing sewer to be removed to conduct the Work. **(10 Calendar Days before Bursting)**

13. Seismic Monitoring Plan (if required), including details of Licensed Structural Engineer to be used for building surveys **(10 Calendar Days before Bursting)**
14. A written verification at least 2 days before commencing bursting that the sewer is free of obstructions and debris and is in suitable condition for bursting. **(2 Calendar Days before Bursting)**
15. Post installation CCTV inspection reports and videos. Post installation reports and videos shall be provided within 10 calendar days after pipe installation and include reinstatement of all laterals **(Within 10 Calendar Days of Busting)**.
16. Process Control Sheet to include equipment tensile or compressive load information, excavation reinstatement, tap cut information and pre and post submittal follow up record/survey inspection report, alignment inspection where bursts are complete. **(Within 10 Calendar Days of Bursting)**
17. HDPE Repair Methods [If required] **(Before Repairs Are Made)**

## 1.06 TRIAL TEST AND METHODOLOGY REVIEW

- A. The Contractor shall comply with the following conditions before a pipe bursting technique becomes accepted as a viable option on a repeat basis:
  1. A successful demonstration for a trial length of sewer pipeline, chosen by the Engineer, which requires pipe-bursting shall be carried out including type and quality control tests as recommended by the manufacturer and in compliance with industry standards.
  2. The Contractor shall include and allow for representation by the equipment manufacturer if requested and further requirement of the Engineer, subsequent to the trial, to modify the equipment, material and/or installation methodology in order to complete the Work satisfactorily and meet all testing standards at no cost to the City.
  3. The Engineer shall formally accept the Contractor as having successfully completed the trial stage should this be the case.

## PART 2 – PRODUCTS

### 2.01 MATERIALS

- A. Polyethylene Plastic Pipe shall be high-density solid wall polyethylene pipe (HDPE) in accordance with specifications in Section 02730, subsection 2.04.
1. Sizes of the insertions to be used shall be as indicated or specified to renew the sewer to greater flow capacity.
  2. All pipes shall be made of virgin material. No reworked material shall be used except that obtained from the manufacturer's own production of the same formulation.
  3. The pipe shall be homogenous throughout and shall be free of visible cracks, discoloration, pitting, varying wall thickness, holes, foreign material, blisters, or other deleterious faults.
  4. Dimension Ratios: The minimum wall thickness of the polyethylene pipe shall be SDR 17 throughout.
  5. Material color shall be light gray. Light gray interior color of pipe shall allow easier/better viewing for television inspection.
  6. Product shall be equal to Driscoplex, manufactured by Chevron Phillips.
- B. Restrained Ductile Iron Pipe (DIP) installed by static push-pull methods shall be centrifugally cast with low profile bells manufactured in accordance with the requirements of ANSI/ AWWA C151/A21.51 and requires a provision of specially designed pulling head by the pipe manufacturer which is compatible pipe joint. In no instance, shall the pulling force exceed the manufacturer's recommendation.
1. Minimum 350 pressure rating.
  2. Boltless restrained joint design capable of a developing a minimum 20,000 pound allowable dead end thrust pulling force without separation or permanent deformation.
  3. Pipe lay lengths shall be the maximum allowable length depending upon the field conditions and in no case less than 8'-0".
- C. Ductile Iron Jacking Pipe (DIP) installed using the TIM™ method shall be ductile iron gravity service push pipe suitable for direct jacking or pushing pipe installation method to be employed.
1. Joints shall be precision cast and/or equipped with a compression cushioning ring to efficiently transfer and distribute the jacking loads through the joint, therefore maximizing the potential length of



- installation. The allowable jacking strength capacity of pipe shall be capable of withstanding the maximum jacking forces to be imposed by the operations.
2. Minimum wall thicknesses shall be adequate to withstand the maximum anticipated jacking loads.
  3. Pipe lining shall be fusion bonded epoxy type with a nominal thickness of 60 mils to prevent potential cracking and or spalls during installation. Cement lining will not be allowed. Acceptable lining products are those equal to Polybond Plus manufactured by American Cast Iron Pipe Company.
  4. The installed pipe shall be capable of providing a positive seal for gravity or low head applications up to 100 feet (43 psi).
  5. Product shall be equal to GS Push Pipe Manufactured by American Cast Iron Pipe Company.
  6. Pipe shall conform to Specification Section 02730 except as otherwise specified in this Section.
- C. Vitrified Clay Pipe (VCP) installed by TIM™ shall be vitrified clay jacking pipe suitable for the direct jacking or pushing pipe installation method to be employed.
1. Pipe shall be manufactured of vitrified clay according to ASTM C 1208. Pipe shall be specifically designed and certified for the jacking application by the pipe manufacturer. The allowable jacking strength capacity of pipe shall be capable of withstanding the maximum jacking forces to be imposed by the operations.
  2. Nominal pipe lengths shall be submitted to the Engineer for approval prior to installation. Lengths shall be customized to accommodate limited space for launching/receiving pits as needed.
  4. Push fit joints shall be precision machined and equipped with an integral compression cushioning ring to efficiently transfer and distribute the jacking loads through the joint, therefore maximizing the potential length of installation. The joints shall consist of a seat, and polyurethane or elastomeric sealing element, a stainless steel sleeve and a compression cushion ring. The jointing sleeve shall be of AISI Type 316 stainless steel. The jointing seals shall be made of polyurethane or EPDM rubber, or other approved elastomeric material. The compression cushion ring between the joint ends shall conform to ANSI 280.1.

5. Saddles, repairs and other connections to the vitrified clay pipe may be sealed with an approved epoxy resin. The epoxy resin shall be Epibond 157 manufactured by Furane Plastics; WR623 A&B manufactured by Wyndam Chemicals, Inc.; EPON 828 manufactured by Shell Chemical Corp., Wyn-Stik ES-23 A&B or ES-4 A&B , manufactured by PTW&M Industries, Inc. or approved equal.
6. VCP Pipe products shall be equal to those manufactured by Can Clay Corporation.

## **2.02 DELIVERY, STORAGE, AND HANDLING**

- A. Transportation, handling, and storage of the pipe and fittings shall be as recommended by manufacturers.
- B. If new pipe and fittings become damaged before or during installation, it shall be repaired as recommended by the manufacturers or replaced as required by the Engineer at the Contractor expense, before proceeding further.
- C. Deliver, store and handle other materials as required to prevent damage.

## **2.03 MATERIAL TESTS**

- A. A certificate shall be furnished by the manufacturer for all material furnished under this specification. Pipe and fittings may be rejected that do not meet any requirements of this specification.
- B. Upon request by the Engineer, the Contractor shall furnish samples for material tests by the City's independent laboratory demonstrating compliance with Specification Section 02730 for HDPE pipe and fittings to verify the required physical properties and characteristics of supplied materials. The City shall pay for tests on pipe samples that meet specification requirements. Contractor shall pay for failed tests and re-testing of failed materials.

## **2.04 EQUIPMENT**

- A. The pipe-bursting tools shall be designed and manufactured to force its way through existing, pipe materials, by fragmenting the pipe and compressing the old pipe sections into the surrounding soil as it progresses. The bursting unit shall generate sufficient force to burst and compact the existing pipeline. See manufacturer's specifications for appropriate tool sizing for various pipe diameters, as well as parameters of tool sizing for percentage of upsize allowed.

- B. Pneumatic or static pipe-bursting tool bursting head shall be pulled through the existing sewer by a winch or jack located at the reception manhole when installing new HDPE or DIP. The bursting unit shall pull the pipe with it as it moves forward. The bursting head shall incorporate a shield/expander to prevent collapse of the hole ahead of the pipe insertion. The pipe-bursting unit shall be remotely controlled.
1. The bursting action of the tool shall increase the external dimensions sufficiently, causing breakage of the pipe at the same time expanding the surrounding ground. This action shall not only break the pipe but also create the void into which the burster can be winched or towed by extension rod and enable forward progress to be made. At the same time the pipe, directly attached to the sleeve on the rear of the burster shall also move forward.
  2. For HDPE pipe installations, the burster shall have its own forward momentum while being assisted by winching. A hydraulic winch shall give the burster friction by which it can be move forward. To form a complete operating system, the burster must be matched to a constant tension hydraulic winching system.
- C. The tenbusch insertion method (TIM™) equipment shall be utilized to jack the new pipe into the existing sewer by using the new pipe as a support column. The front jack advances the bursting unit into the existing pipe independent of the advance of the new pipe column. The new pipe is jacked behind the bursting unit piece by piece by the jacking frame (in the work pit). The primary jacking frame applies the required thrust to advance the new pipe column (as the front jack is retracted). Instrumentation and controls at the operator's control panel (at the jacking frame) shall allow the operator to control the jack through the existing pipe as the new pipe column and bursting unit are "inch-wormed" into the existing sewer.
1. The jacking system shall be capable of continuously monitoring the jacking pressure, the rate of advancement and the distance jacked.
  2. The jacking equipment shall have the capability of limiting the jacking force applied so as not to exceed the maximum compressive loads allowed for the replacement pipe.

## **PART 3 – EXECUTION**

### **3.01 EXISTING UTILITIES AND OBSTRUCTIONS**

- A. Refer to Section 02730, subsection 3.01

### **3.02 SEWER SERVICE CONNECTIONS**

- A. Refer to Section 02730, subsection 3.06 for service reconnections.

### **3.03 EXISTING FLOW**

- A. The Contractor shall provide bypass pumping as detailed in Specification Section 02750 – Wastewater Flow Control.
- B. The Contractor shall be responsible for maintaining continuous sanitary sewer service to each property connected to the segment of sewer subject to pipe bursting operations.
- C. If sewage backup occurs and enters buildings, the Contractor shall be responsible for clean-up, disinfection, repair, property damage, as well as resultant costs and claims.

### **3.04 PRE-INSTALLATION CCTV INSPECTION**

- A. Pipelines that will be upgraded by pipe-bursting and shall be televised (CCTV) in conformance with the City of Atlanta Specification for Internal Sewer Condition Assessment for CCTV sewer inspection. (Section 02752)

CCTV inspection conditions shall include the following:

1. Preconstruction video CDs shall be available for viewing by the Engineer before construction begins and throughout the project.
2. Video CDs shall remain property of the City. Contractor shall retain second copy for internal use.
3. All flows tributary to reach of sewer being inspected are to be completely by-passed around the reach during preconstruction inspection if necessary and required by the City.
4. If any portion of the inspection video is of inadequate quality or coverage, as determined by the City, the Contractor will have the portion re-inspected at no additional expense to the City.

### **3.05 CORRECTION OF PIPE SAG OR BLOCKAGE**

- A. Significant sags in the sewer pipe or a blockage must be corrected prior to renewing the sewer pipe by pipe bursting. Correction will be accomplished by point repair as specified in Section 02757.

### 3.06 CONSTRUCTION METHOD

- A. Equipment used to perform the Work shall be located away from buildings in order to minimize noise impact, which under all circumstances shall be less than 70 dB unless otherwise allowed by the Engineer due to circumstances beyond the Contractor or pipe-bursting Subcontractor. A silent engine compartment with the winch shall be provided to reduce machine noise.
- B. The Contractor shall install all pulleys, rollers, bumpers, alignment control devices and other equipment required to protect existing manholes, and to protect the new pipe from damage during installation. Lubrication may be used as recommended by the manufacturer. Under no circumstances shall the pipe be stressed beyond its elastic limit (polyethylene) or compressive or tensile limit (vitrified clay and ductile iron).
- C. Installed polyethylene pipe shall be allowed to relax and cool following installation in accordance with the manufacturer's recommended time, but not less than a minimum of four (4) hours prior to any reconnection of service lines, scaling of the annulus, or backfilling of the insertion pit, unless otherwise allowed by the Engineer. Sufficient excess length of new pipe, but not less than four (4) inches, shall be allowed to protrude into the manhole to provide for further length reduction. End restraint of pipe ends shall be achieved by means of Central Plastics Electrofusion couplings, or approved equal. The Electrofusion couplings shall be slipped over pipe ends against manhole wall and fused in place. Installation of all electrofusion couplings shall be carried out in accordance with the manufacturers recommended procedures.
- D. Following a relaxation period of four (4) hours for polyethylene pipe, the annular space shall be sealed. Sealing shall be made with a ¼" to ½" diameter activated oakum band soaked in pre-polymer urethane resin sealant equal to AV-219 manufactured by Avanti International. Seal annular space circumferentially at the gap and extend sealant a minimum of four (4) inches through the manhole wall into the manhole in such a manner as to form a smooth, uniform, watertight joint. The terminating pipe ends in manholes shall be connected by Central Plastics Electrofusion couplings, or approved equal, to eliminate ground water infiltration. Installations of electrofusion couplings shall be installed in accordance with the manufacturers recommended procedures.
- E. Vitrified clay and ductile iron terminating pipe ends in manholes shall be connected to manholes in accordance with Section 02730.

- F. If an existing structure or utility is closer than fifty feet from a bursting unit, the Contractor shall use the services of a seismic monitoring company to record any disturbance to the structure or utility. The peak particle velocity resulting from bursting shall not exceed the following frequencies:
1. Less than 3 Hz: 0.2 inches/second
  2. 3– 10 Hz: 0.5 inches/second
  3. 10 – 40 Hz: Varying linearly 0.5 to 1.0 inch/second
  4. Greater than 40 Hz: 1.0 inches/second
  5. The above limits are adopted from modified blasting level criteria given in U.S. Bureau of Mines Recommendations RI-8507. No bursting will be allowed until the monitoring instrument(s) are in place and a monitoring plan is submitted to the Engineer.
  6. If the diameter of the pipe to be replaced is less than 18 inches, then existing structures within 25 feet of the bursting unit shall receive a full structural survey by a Georgia licensed Engineer. If the diameter of the pipe to be replaced is 18 inches and greater, then existing structures within 50 feet of the bursting unit shall receive a full structural survey by a Georgia Licensed Engineer.
- G. The Contractor shall use pipe-carrying rollers to keep polyethylene pipe above flowers, shrubs, and other vegetative or structural landscaping features that could be damaged by contact with the pipe.
- H. Protection and restoration of work area disturbance to the ground surface resulting from heave during pipe-bursting shall be corrected to meet the Engineer's requirements and the area shall be restored in accordance with the Specifications.
- I. Install anti-flotation measures for polyethylene pipe wherever ground cover will be less than four feet (4 ft) and is below the groundwater level. Refer to Section 02730. Ensure that bursting can proceed under shallow depth conditions without detrimental ground heave or loss of control of bursting head.

### **3.07 POST-INSTALLATION CCTV INSPECTION**

- A. All costs associated with the post-installation CCTV inspection shall be considered incidental to the pipe-bursting work.

- B. Following the installation of the new pipelines, CCTV inspection shall be performed in accordance with the requirements of the City of Atlanta Specification of Internal Sewer Condition Assessment (Section 02752 in these Specifications). The finished video shall be continuous over the entire length of the sewer between two manholes and shall be completely free from visual defects.
- C. Defects, which may affect the integrity or strength of the pipe in the opinion of the Engineer, shall be repaired or the pipe replaced at the Contractor's expense.
- D. Video shall remain property of the City. Contractor shall retain second copy for internal use.
- E. The post-installation CCTV inspection shall take place as shortly after completion of each section as is feasible, but in no case more than ten (10) calendar days thereafter. The contractor is required to submit the post-installation CCTV videos within ten (10) calendar days of completing the rehabilitation of a segment of the sewer. Post construction video and a CD-ROM conversion of the documented videos shall be submitted to the City before final invoices, reduction of retainage or release of any retainage withheld.
- F. If any portion of the inspection tapes is of inadequate quality or coverage, as determined by the City, the Contractor will have the portion re-inspected and video taped at no additional expense to the City.

### **3.08 HDPE PIPE JOINING**

- A. The polyethylene pipe shall be assembled and joined at the site using the butt-fusion method to provide a leak proof joint in strict accordance with the manufacturer's instructions and ASTM D 2657. Threaded or solvent-cement joints and connections are not permitted.
- B. All equipment and procedures used shall be used in strict compliance with the manufacturer's instructions and recommendations. Fusing shall be accomplished by personnel who are certified as fusion technicians by a manufacturer of polyethylene pipe and/or fusing equipment.
- C. The butt-fused joint shall be true alignment and shall have uniform rollback beads resulting from the use of proper temperature and pressure. The joint shall be allowed adequate cooling time before removal of pressure. The fused joint shall be watertight and shall have tensile strength equal to that of the pipe.
- D. All joints shall be subject to acceptance by the Engineer and/or Engineer's representative prior to insertion. All defective joints shall be cut out and

replaced at no cost to the City. Any section of the pipe with a gash, blister, abrasion, nick, scar, or other deleterious fault greater in depth than ten percent (10%) of the wall thickness, shall not be used and must be removed from the site. However, a defective area of the pipe may be cut out and the joint fused in accordance with the procedures stated above.

- E. Any section of the pipe having other defects such as concentrated ridges, discoloration, excessive spot roughness, pitting, variable wall thickness or any other defect of manufacturing or handling as determined by the Engineer and/or his representative shall be discarded and not used.
- F. Terminal sections of pipe that are joined within the insertion pit shall be connected with Central Plastics Electrofusion Couplings or connectors with tensile strength equivalent to or greater than that of the pipe being joined.

### **3.09 INFILTRATION AND EXFILTRATION TESTING**

- A. Pipelines rehabilitated and replaced shall be tested for watertightness in accordance with Specification Section 02730. This applies to ductile iron, HDPE and vitrified clay replacement pipe. All inlets to the system shall be effectively closed and any residual flow shall be deemed to be infiltration.
- B. Notwithstanding the satisfactory completion of the above test for pipelines, if there is any discernible flow of water entering rehabilitated pipelines or manholes, at a point that can be located by visual or CCTV inspection, the Contractor shall take such additional measures required by the Engineer to stop infiltration at the Contractor's expense.
- C. All costs associated with the watertightness test and foregoing requirements shall be considered incidental to the work and shall be included in the unit price.

### **3.10 POST INSTALLATION DEFLECTION**

- A. All polyethylene pipe installed by pipe-bursting shall be subjected to a visual deflection check to determine if ovality greater than 10% exists by observation of the post installation CCTV inspection.
- B. The deflection test shall be performed by the Contractor in the presence of the Engineer. All costs associated with the deflection test and foregoing requirements shall be considered incidental to the pipe-bursting work and shall be included in the unit price for pipe-bursting.



## **PART 4 – WARRANTY**

### **4.01 MATERIAL WARRANTY**

- A. A written guarantee of 5 years, submitted to the City for the specific project, shall be provided by the Manufacturer against any breakdown of the polyethylene pipe material effectiveness.

### **4.02 WORKMANSHIP WARRANTY**

- A. A written guarantee of 2 years minimum shall be provided by the Contractor against any shortcoming in Workmanship.

END OF SECTION

### Attachment A

#### PROCESS CONTROL SHEET - PIPE BURSTING (Following Mainline or Lateral Burst)

The Contractor shall complete a Process Control Sheet for each pipeline replaced and shall submit a copy to the Engineer immediately following the bursting operation and it's inspection. The Process Control Sheet shall include the information below as a minimum unless otherwise modified by the Engineer. In the event there are more than one inspector or contractor confirming the process completion per form, each section should be initiated by the performing inspector. All sections that were not completed due to lack of applicability to the replacement method used should have "N/A" entered.

Date(s) Rehabilitation Carried Out: \_\_\_\_\_

Date Process Control Sheet Completed: \_\_\_\_\_

General Process Control Section		
- state whether process control sheet completed for Mainline , or Lateral		
<b>General</b>	WEATHER ETC: Prior to Commencing Burst (include air temperature)	
	During Burst (include air temperature)	
	Number of Cleanouts?	
	LATERAL CONNECTION(S): • Type - circle	SIDE CROWN SPRINGING INVERT --straight entry --bend entry
	• Number (ea), Clock ref. from US MH	NO.....
	• Sizes (in)	
	Laterals Rehabbed? Type and Distance (ft) from Upstream MH <i>Complete separate form for laterals Pipe-burst or CIPP lined.</i>	
	Number of Local Repairs. Type and Distance (ft) from Upstream MH or from Mainline	
	Confirm all surface structures adjacent to burst inspected, recorded if defective, and structurally adequate for work to proceed. <input type="checkbox"/> Yes <input type="checkbox"/> No	If no explain here:
	Confirm line CCTV'd and agreed bursting viable <input type="checkbox"/> Yes <input type="checkbox"/> No	If no explain here:
Confirm line cleaned and prepared for bursting <input type="checkbox"/> Yes <input type="checkbox"/> No	If no explain here:	
<b>Location</b>	Upstream Manhole ID <input type="checkbox"/> Entry <input type="checkbox"/> Reception	MH#
	Downstream Manhole ID <input type="checkbox"/> Entry <input type="checkbox"/> Reception	MH#
	Intermediate Manhole ID(s), if applicable	MH#
	Street Name(s)/Address <input type="checkbox"/>	
<b>Material Composition Details</b>	INSTALLED PIPE: • Welded length (ft)	
	• Installed length (ft)	
	• Material - circle one	HDPE PVC DIP CLAYWARE OTHER (state):
	MANHOLE COUPLING/ <input type="checkbox"/>	
<b>Pipe Installation</b>	MAINLINE CONNECTION: • Type and Number (ea)	
	• Nominal Sewer Size (in)	
	INSTALLATION METHOD **	
	Bursting Time	Start Time Finish Time
<b>By Pass /Reinstate Flow</b>	Relaxation Time	Start Time Finish Time
	Taps - Installation Dates not applicable	Start Date Finish Date
	List Taps and Footages (ea) not applicable	
	List Abandoned Service Footages (ea) not applicable	
<b>Welding HDPE</b>	WINCH DETAILS: • Type / Make	
	• Load Capacity	
	By Pass Commenced (Date/Time) not applicable	
	Main Flow Reinstated (Date/Time) not applicable	
<b>Signatures</b>	Excavations Reinstated and Accepted? <input type="checkbox"/> Yes <input type="checkbox"/> No	
	WELDING DETAILS: • Date / Time	
	• Number of Welds	
	DAMAGE RECTIFICATION, IF ANY: • Footage ? Rectification?	
<b>Contractor</b>	WELD TESTS: • Method	
	• Failures? Rectification?	
<b>Inspector</b>	By signing below, I agree that the above General Process Control section has been inspected and confirmed. I understand that I have the right to indicate, by my initials, which sections I am confirming if I have not completed all of the inspections myself. I am aware that all sections left blank will be considered incomplete and may be sent back with request for additional information.	By signing below, I agree that the above General Process Control section has been inspected and confirmed. I understand that I have the right to indicate, by my initials, which sections I am confirming if I have not completed all of the inspections myself. I am aware that all sections left blank will be considered incomplete and may be sent back with request for additional information.
	Type/Print Name Here Signature X	Type/Print Name Here Signature X

OVER

Contractor Specific Process Control Section		
<b>Material Composition Details</b>	PIPE MATERIAL: <ul style="list-style-type: none"> <li>• Manufacturer / Joint Type</li> <li>• Nominal Pipe Size</li> <li>• Actual Inside Diameter (in)</li> <li>• Wall Thickness (in) or Class</li> </ul>	
	SEISMOMETER: <input type="checkbox"/> Yes <input type="checkbox"/> No <ul style="list-style-type: none"> <li>• Type/Make</li> <li>• Range</li> <li>• Calibrated?</li> <li>• Crack Monitor Results (if applicable)</li> <li>• Red Zone Incident (s)?</li> <li>• Yellow Zone Incident (s)?</li> <li>• Other - Range</li> </ul>	
	<b>Contractor</b>	
	I agree that the above Contractor Specific Process Control Section is complete and accurate to the best of my knowledge. I understand that all sections that are left blank will be considered incomplete sections and may be sent back for additional information. Type Name Here   Signature X	

\* Red Zone - > 0.75 inch per second < 1.0 inch per second; Yellow Zone >0.5 inch per second< 0.75 inch per second  
 \*\* Please indicate which method was used: e.g., Pneumatic (P), Static (S), Other (Tennbusch, Hydraulic)

(This page is intentionally blank)

---

**SECTION 02730**

**Sewers and Accessories**

**PART 1 – GENERAL**

**1.01 SCOPE**

- A. This Section describes products to be incorporated into sewers and accessories and requirements for the installation and use of these items. Furnish all products and perform all labor necessary to fulfill the requirements of these Specifications.
- B. General: Supply all products and perform all work in accordance with applicable American Society for Testing and Material (ASTM), American Water Works Association (AWWA), American National Standards Institute (ANSI), or other recognized standards. Latest revisions of all standards are applicable.

**1.02 QUALIFICATIONS**

- A. If requested by the Engineer, submit evidence that manufacturers have consistently produced products of satisfactory quality and performance for a period of at least two years.

**1.03 SUBMITTALS**

- A. If required by the City or Engineer, complete product data and engineering data shall be submitted to the Engineer in accordance with the requirements of General Condition Section 28 of the Contract Documents.

**1.04 TRANSPORTATION AND HANDLING**

- A. Unloading: Furnish equipment and facilities for unloading, handling, distributing and storing pipe, fittings, valves and accessories. Make equipment available at all times for use in unloading. Do not drop or dump materials. Any materials dropped or dumped will be subject to rejection without additional justification.
- B. Handling: Handle pipe, fittings, valves and accessories carefully to prevent shock or damage. Handle pipe by rolling on skids, forklift, or front loader. Do not use material damaged in handling.
- C. Lined pipe shall be handled and transported to prevent damage to linings.

## 1.05 STORAGE AND PROTECTION

- A. Make arrangements for the use of suitable storage areas for piping and other materials required for the Work.
- B. Stored materials shall be kept safe from damage. The interior of all pipes, fittings and other appurtenances shall be kept free from dirt or foreign matter at all times.
- C. Pipe shall not be stacked higher than the limits recommended by the manufacturer. The bottom tier shall be kept off the ground on timbers, rails or concrete. Pipe in tiers shall be alternated “bell, plain end,” “bell, plain end.” At least two rows of timbers shall be placed between tiers and chocks, affixed to each other in order to prevent movement. The timbers shall be large enough to prevent contact between the pipes in adjacent tiers.
- D. Store joint gaskets in a cool location, out of direct sunlight. Gaskets shall not come in contact with petroleum products. Gaskets shall be used on a first-in, first-out basis.
- E. PVC pipe and fittings shall not be stored in direct sun light.

## 1.06 QUALITY ASSURANCE

- A. Product manufacturers shall provide the Engineer with written certification that all products furnished comply with all applicable provisions of these Specifications.
- B. If ordered by the Engineer, each pipe manufacturer shall furnish the services of a competent factory representative to supervise and/or inspect the installation of pipe. This service will be furnished for a minimum of five days during initial pipe installation.
- C. Upon request by the Engineer, the Contractor shall furnish samples for material tests by the City’s independent laboratory demonstrating compliance with this Specification to verify the required physical properties and characteristics of supplied materials. The City shall pay for tests on pipe samples that meet specification requirements. Contractor shall pay for failed tests and re-testing of failed materials.

## PART 2 – PRODUCTS

### 2.01 DUCTILE IRON PIPE (DIP)

- A. Ductile iron pipe shall be utilized where shown on the Drawings or directed by the Engineer.
- B. Ductile iron pipe shall be manufactured in accordance with AWWA C151. All pipes, except specials, shall be furnished in nominal lengths of 18 to 20 feet. Sizes will be as shown on the Drawings. All pipes shall have a minimum pressure rating as indicated in the following table, and corresponding minimum wall thickness, unless otherwise specified, or shown on the Drawings. Pipe wall thickness shall be determined based on dead loads indicated on the Drawings and the anticipated live loads, assuming a minimum HS 20 live load.

Pipe Sizes (inches)	Pressure Class (psi)
4 - 12	350
14 - 20	250
24	200
30 - 60	150

- C. Fittings and Accessories:
- Fittings shall be ductile iron and shall conform to AWWA C110/ANSI A21.10 or AWWA C153/ANSI A21.53, with a minimum rated working pressure of 250 psi.
  - Flanged elbow fittings shall be ANSI pattern using short radius elbows, except where noted differently on the Drawings. Special fittings, ductile iron wall pipes and sleeves shall conform to the dimensions and details as shown on the Drawings.
- D. Joints for Ductile Iron Pipe and Fittings:
- General:
    - Joints for ductile iron pipe and fittings shall be mechanical joints, restrained, flanged or push-on joint as specified herein or in Section 02725.

- b. Unless otherwise shown on the Drawings, specified or directed, all ductile iron pipe laid underground shall be joined using push-on type joints.
  - c. In all cases, gaskets shall be made of material that will not be damaged by the fluid being transported or by the environment in which the pipe is installed.
  - d. Provide the necessary bolts for connections. All bolts and nuts shall be threaded in accordance with ANSI B1.1, Coarse Thread Series, Class 2A external and 2B internal fit. All bolts and nuts shall be made in the U.S.A.
2. Mechanical Joints:
- a. Joints shall conform to AWWA C111/ANSI A21.11.
  - b. Bolts and nuts shall be Tee Head Bolts and nuts of high strength low-alloy steel in accordance with ASTM A 242 to the dimensions shown in AWWA C111/ANSI A21.11.
  - c. Gaskets shall be in accordance with AWWA C111/ANSI A21.11 and shall be constructed of plain rubber.
  - d. Mechanical joint glands shall be ductile iron.
3. Push-On Joints: Push-on joints and gaskets shall conform to AWWA C111/ANSI A21.11. Details of the joint design shall be in accordance with the manufacturer's standard practice such as ACIPCO "Fastite," McWane (Clow) "Bell-Tite," or U.S. Pipe "Tyton" joints.
- E. Linings & Coatings: Sewer pipe and fittings shall be cement lined in accordance with ANSI/AWWA C104/A21.4.
- F. Polyethylene Encasement: Polyethylene film shall meet the requirements of AWWA C 105.
- G. Wall Sleeves and Wall Pipes:
1. Where piping passes through concrete structures, furnish and install wall sleeves unless wall pipes or other provisions are specifically shown on the Drawings. Wall sleeves shall be accurately located and securely fastened into position before concrete is poured.
  2. Wall Sleeves:



- a. For pipe sizes smaller than 3-inches, wall sleeves shall be steel oversize sleeves furnished with a full circle, integral or continuously welded waterstop collar. The sleeve seal shall be the mechanically expanded, synthetic rubber type. Provide all associated bolts, seals and seal fittings, pressure clamps, or plates necessary to achieve a watertight installation. Sleeves shall extend the full thickness of the concrete. Sleeves and seal shall be Link Seal.
- b. For larger pipe sizes, wall sleeves shall be ductile iron mechanical joint wall sleeves. Unless specified or shown otherwise for a specific situation, wall sleeves shall be mechanical joint bell-plain end types with waterstop/thrust collar. The collar shall be capable of withstanding a thrust force caused by a 250 psi dead end load from either direction on that size pipe. Sleeves shall be constructed with studs and mechanical joint retainer gland on the air side of the concrete structure. Provide retainer gland where shown on the Drawings. Where the concrete structure is exposed to dirt on one side and is wet on the other side, construct with studs and glands on the dirt side. Wall sleeves shall be equal to ACIPCO A-10771.

3. Wall Pipes:

- a. Wall pipes shall be either ductile iron with integral waterstop/thrust collar or centrifugally cast ductile iron with a continuously welded waterstop/thrust collar. The welded on collar shall be attached to the pipe by the manufacturer. The collar shall be capable of withstanding a thrust force caused by a 250 psi dead end load from either direction on that size pipe. Wall pipes shall be furnished uncoated on the outside and cement lined on the inside. Unless specified or shown otherwise, wall pipes shall be flange end types.
- b. Wall pipes shall be cast and/or fabricated and lined in one manufacturer's facilities and delivered to the job site ready for use.

## 2.02 REINFORCED CONCRETE PIPE (RCP)

A. Pipe:

1. Pipe shall be bell and spigot reinforced concrete conforming to ASTM C 76 for Class III, IV and V pipe as shown on the Drawings.

2. In addition, the pipe and materials shall meet the following requirements:
    - a. Concrete shall have a minimum compressive strength of 5,000 psi for Class III and IV and 6,000 psi for Class V
    - b. Cement shall meet the requirements of ASTM C 150, Type II
    - c. Absorption shall not exceed six percent when tested in accordance with ASTM C 497.
  3. Reinforced concrete pipe shall be supplied in lengths of at least eight feet, except for specials.
- B. Joints: Pipe shall have concrete and rubber O-ring gasket type joints conforming to ASTM C 361. A rectangular groove shall be supplied in the spigot end to receive the rubber O-ring gasket, and it shall be so formed that when the joint is complete the gasket will be deformed to a rectangular shape and confined on all four sides. Bell and spigot surfaces shall be accurately formed and smooth to provide a close sliding fit with a nominal clearance of 1/16-inch.
- C. Fittings and Specials: Reinforced concrete pipe fittings and specials shall meet all requirements for reinforced concrete pipe, including materials of construction, structural strength, linings, and joints. Provide special adapters or transition pieces for connection to pipe of different materials where shown on the Drawings.
- D. Acceptance:
1. Acceptance of pipe shall be based on plant load-bearing tests for the load to produce 0.01-inch crack, material tests, and inspection of manufactured pipe for visual defects and imperfections as described in Paragraph 5.1.1 of ASTM C 76.
  2. Provide results of tests on pipe, pipe materials, joint material, and made-up joints performed by an independent testing laboratory approved by the Engineer. Include materials, absorption, crushing, and hydrostatic leakage tests on pipe of each size in accordance with applicable specifications.
  3. Each length of pipe shall be stamped by a regular employee of the approved testing laboratory.

4. Inspect pipe after delivery for laboratory stamp, shape, cracks, uniformity, blisters and imperfect surfaces, hammer test, damaged ends, and gasket grooves. Do not accept or use pipe with repaired or patched gasket grooves or shoulders. Any pipe repaired or patched is subject to rejection if such repairs or patches, in the opinion of the Engineer or City, are not sound and properly finished.
5. The City shall, at its own discretion, select another independent testing laboratory to confirm those tests performed by the manufacturer's testing laboratory. This testing laboratory shall observe the tests conducted by the laboratory selected by the manufacturer, or, as necessary, conduct its own tests. The manufacturer shall provide the necessary facilities for the performance of these tests at the plant site. These test specimens shall be provided in accordance with paragraph 11 of ASTM C 76.
6. No pipe shall be shipped before it has been cured for a minimum of 14 days.

**2.03 POLYVINYL CHLORIDE (PVC) GRAVITY SEWER PIPE**

- A. Acceptability of PVC pipe for gravity sewers is indicated in the following table:

Standard Minimum Thickness Type PVC <sup>1</sup>	Wall	Acceptable Manufacturers	≤ 6	8 to 15	18	21	24
ASTM D 3034 SDR 35 12454B	Solid Wall	Open	Yes	Yes	No	No	No

<sup>1</sup> As specified in ASTM D 1784

- B. All pipes shall have a minimum pipe stiffness of 46 psi at five percent deflection as determined by ASTM D 2412.
- C. PVC gravity sewer pipe shall be supplied in lengths not longer than 13 feet.
- D. Fittings:
1. Fittings 15 inches in diameter and less shall be manufactured in accordance with ASTM D 3034. PVC compound shall be 12454B or 12454C as specified in ASTM D 1784.

2. For sizes 8-inches and less in diameter, fittings shall be molded in one-piece with no solvent welded joints. Minimum socket depths shall be as specified in ASTM D 3034, Table 2.
  3. For sizes 10-inches and larger in diameter, fittings shall be fabricated from pipe conforming to ASTM D 3034 using solvent welding. No field fabrication of fittings will be allowed. All such fabrication shall be performed at the factory and the fittings shall be delivered ready for use.
  4. 4-inch and 6-inch cleanout piping assembly shall be constructed with by connecting the cleanout branch to the lateral with a 2-way, smooth flowing sanitary cleanout tee to facilitate the insertion of a sewer snake or exploratory flexi-cameras for either direction. The 2-way cleanout fitting shall be manufactured with gasketed hub connections. Solvent weld connections will not be allowed. Acceptable manufacturers are those equal to Plastic Trends, Inc. Part No. G1006.
  5. Fittings 18 inches in diameter and larger shall be fabricated from pipe conforming to ASTM F 679 using solvent welding. No field fabrication of fittings will be allowed. All such fabrication shall be performed at the factory and the fittings shall be delivered ready for use.
- E. Joints: Joints for pipe and fittings shall be of the integral bell and spigot type with a confined elastomeric gasket having the capability of absorbing expansion and contraction without leakage, when tested in accordance with ASTM D 3212. Gaskets shall meet the requirements of ASTM F 477. The joint system shall be subject to the approval of the Engineer and shall be identical for pipe and fittings.
- F. Manhole Connections - Solid Wall Pipe: The sewer shall be connected to manholes utilizing a boot connection.
- G. Acceptance: Acceptance will be based on the Engineer's inspection and the manufacturer's written certification that the pipe and fittings were manufactured and tested in accordance with the applicable standards.

## 2.04 HDPE PIPE

- A. The pipe supplied under this specification shall be high performance, high molecular weight, high-density polyethylene pipe equal to Driscoplex as manufactured by Chevron Phillips Chemical Company or Camcore™ as manufactured by WL Plastics Corporation. The pipe material shall be Type III, Class C, Category 5, P34 material as described in ASTM D 1248.

Minimum cell classification values of the pipe material shall be (3 4 5 4 3 4 c) as referenced in ATSM D 3350. The SDR shall be 17. The fittings supplied under this specification shall be molded from a polyethylene compound having a cell classification equal to or exceeding the cell classification of the pipe supplied under this specification.

B. Physical Properties of Pipe of Pipe Compound:

1. Density: The density shall be 0.941 – 0.957 gms/cm when tested in accordance with ASTM D 1505.
2. Melt Flow: Melt Flow shall be no greater than 0.11 gm/10 min. When tested in accordance with ASTM D 1238 – Condition E.
3. Flex Modulus: Flexural Modulus shall be 110,000 psi to less than 160,000 psi when tested in accordance with ASTM D 790.
4. Tensile Strength at Yield: Tensile strength at yield shall be 3,200 PSI to less than 3,500 PSI when tested in accordance with ASTM D638.
5. ESCR: Environmental Stress Crack Resistance shall be in excess of 5,000 hours with zero failures when tested in accordance with ASTM D 1693 Condition C.
6. Hydrostatic Design: Basic shall be 1,600 psi at 23-C when tested in accordance with ASTM D 2837.

C. Deviations: If a supplier chooses to submit a bid that does not meet all the requirements of this specification, his bid shall include a written description of the deviation with data that shows the magnitude of the deviation and the justification for the deviation from this specification. The decision to accept material deviating from this specification shall be the responsibility of the specifying engineer.

D. Certification: The City or the specifying engineer may request certified lab data to verify the physical properties of the materials supplied under this specification or may take random samples and have them tested by an independent laboratory.

E. Rejection: Polyethylene pipe and fittings may be rejected for failure to meet any of the requirements of this specification.

F. Pipe Dimensions: Pipe supplied under this specification may be iron pipe size (IPS) or ductile iron pipe size (DIPS) as produced by the manufacturer. IPS or DIPS nominal pipe sizes equal to the pipe

dimension shown on the Drawings shall be provided for all pipe sizes equal to or less than 12 inches. IPS or DIPS actual inside diameter shall be provided which is equal to or greater than the pipe dimension shown on the Drawings for all pipe sizes greater than 12 inches. The SDR (Standard Dimension Ratio) of the pipe supplied shall be as specified by the Engineer.

- G. Color: Material color shall be light gray. Light gray interior color of pipe shall allow easier/better viewing for television inspection.
- H. Anti-flotation Measures: Where ground cover for HDPE pipe is less than four feet (4 ft), antiflotation devices are to be installed in order to overcome potential uplifting forces from groundwater. These devices may include, but are not limited to, precast concrete saddles, gravel-filled saddle bag pipeline weights, or cast-in-place anti-flotation collars (per Detail 21 on the Drawings). Wherever such a device is to be installed, the Contractor shall be responsible for performing the necessary calculations to ensure that the pipe will not float AND that the pipe and/or antiflotation device will not be overstressed. The pipe manufacturer's allowable shear stress, compressive stress due to buckling and thermal expansion shall be considered in the calculations. Minimum factor of safety against flotation is 1.5. These calculations shall be submitted with shop drawings for anti-flotation devices when such devices are required.

## 2.05 HDPE MANHOLES

- A. Material: The material used under this specification shall be high performance, high molecular weight, high density polyethylene plastic compound having a cell classification of 334433C or higher. The material must have a proven capacity for sustaining long term stresses (radial loading, ring compressive thrust, bending, buckling, axial strain, axial buckling, and groundwater effects) as quantified under ASTM Test Method D2837 or other applicable testing procedures under ASTM.
- B. Appurtenances:
  - 1. Polyethylene Manhole Covers: Polyethylene flat-plate covers shall be designed to withstand light live-loads, such as light equipment and personnel. All manhole covers shall prove to meet this requirement through either physical testing or design calculations. If subject to repeated vehicular loading, the cover should be capped or cast in concrete.
  - 2. Risers: All riser sections shall be joined by thermal fusion or gasket joints. Where risers are joined by a gasket joint, the joints must meet the requirements of Specification D 3212.

3. Cones: Where gasket joints are required to seal the connection between a manhole cone or top, the gasket joint shall prove to provide an adequate seal against the maximum water-head expected for the joint in question.
4. Antiflotation Devices: Where manhole risers extend below the groundwater level, antiflotation devices are to be installed in order to overcome any foreseen uplifting forces. These devices may include, but are not limited to, anchoring to a concrete slab, or attaching a concrete ring to the base or riser. Wherever such a device is to be installed, the Contractor shall be responsible to perform the necessary calculations to ensure that both the manhole will not float AND that the antiflotation device will not be overstressed. These calculations shall be included with the shop drawing submittals.
5. Pipe Connection: Each HDPE manhole will have a stub for all pipes entering and leaving the chamber. The Contractor shall supply under this section all necessary connections, couplings, etc., to join adjacent pipe to HDPE stub pipe.

## **2.06 PRECAST CONCRETE MANHOLES AND PRODUCTS**

### **A. Precast Concrete Sections:**

1. Precast concrete sections shall meet the requirements of ASTM C 478 or ASTM C 913. The minimum compressive strength of the concrete in precast sections shall be 4,000 psi.
2. Wall thickness shall be as shown on the Drawings.
3. Transition slabs or cones that convert bases larger than four feet in diameter to four foot diameter risers shall be designed by the manhole manufacturer to carry the live and dead loads exerted on the slab.
4. Seal joints between precast sections by means of rubber O-ring gaskets or flexible butyl rubber sealant. Butyl rubber sealants shall meet the requirements of AASHTO M-198. Sealant shall be pre-formed type with a minimum nominal diameter of 1-inch. Butyl rubber sealant shall be equal to Kent Seal No. 2 or Concrete Sealants CS202.
5. Each section of the precast manhole shall have not more than two (2) holes for the purpose of handling and laying. These holes shall

be tapered and shall be plugged with rubber stoppers or mortar after installation.

6. Polypropylene plastic manhole steps shall be installed in each section of the manhole in accordance with the City of Atlanta standard details.
- B. Brick and Mortar: Brick shall be whole and hardburned, conforming to ASTM C 32 Grade MS. Mortar shall be made of one part Portland cement and two parts clean sharp sand. Cement shall be Type 1 and shall conform to ASTM C 150. Sand shall meet ASTM C 144.
  - C. Foundations: A prepared foundation shall be placed for all brick structures after the foundation excavation is completed and accepted. Unless otherwise specified, the base shall consist of reinforced concrete mixed, prepared, and placed in accordance with the requirements of Section 03300. The foundation shall be built to the correct elevation and shall be finished to cause the least possible resistance to flowing water.
  - D. Laying Brick: All brick shall be clean and thoroughly wet before laying so that they will not absorb any appreciable amount of additional water at the time they are laid. All brick shall be laid in freshly made mortar. Mortar that is not used within 45 minutes after water has been added shall be discarded. Retempering of mortar shall not be permitted. An ample layer of mortar shall be spread on the beds and a shallow furrow shall be made in it, which can be readily closed by the laying of the brick. All bed and head joints shall be filled solid with mortar. End joints of stretchers and side or cross joints of headers shall be fully buttered with mortar and a shoved joint made to squeeze out mortar at the top of the joint. Any bricks that may be loosened after the mortar has taken its set shall be removed, cleaned, and relaid with fresh mortar. No broken or chipped brick shall be used in the face, and no spalls or bats shall be used except where necessary to shape around irregular openings or edges; in which case, full bricks shall be placed at ends or corners where possible, and the bats shall be used in the interior of the course. In making closures, no piece of brick shorter than the width of a whole brick shall be used; and wherever practicable, whole brick shall be used and laid as headers.
  - E. Joints: All joints shall be slushed with mortar at every course, but slushing alone will not be considered adequate for making an acceptable joint. Exterior faces shall be laid up in advance of backing. Exterior faces shall be back plastered or pargeted with a coat of mortar not less than ½ -inch thick before the backing is laid up. Prior to pargeting, all joints on the back of face courses shall be cut flush. Unless otherwise noted, joints shall be not less than ¼-inch or more than ½-inch wide and whatever width is adopted shall be maintained uniform throughout the work.



- F. Pointing: Face joints shall be neatly struck, using the weather joint. All joints shall be finished properly as the laying of the brick progresses. When nails or line pins are used, the holes shall be immediately plugged with mortar and pointed when the nail or pin is removed.
- G. Cleaning: Upon completion of the work, all exterior surfaces shall be thoroughly cleaned by scrubbing and washing down with water and, if necessary to produce satisfactory results, cleaning shall be done with a 5 percent solution of muriatic acid, which shall then be rinsed off with liberal quantities of clean fresh water.
- H. Curing and cold weather protection: In hot or dry weather, the brick masonry shall be protected and kept moist for at least 48 hours after laying the brick. Brick masonry work or pointing shall not be done when there is frost in the brick or when the air temperature is below 50 degrees F, unless the Contractor has on the project, ready to use, suitable covering and an artificial heating devices necessary to keep the atmosphere surrounding the masonry at a temperature of not less than 60 degrees F for the duration of the curing period.
- I. Iron Castings:
1. Cast iron manhole frames and covers shall meet the requirements of ASTM A 48 for Class 30 gray iron and all applicable local standards. All castings shall be tough, close grained, smooth, and free from blow holes, blisters, shrinkage, strains, cracks, cold shots and other imperfections. No casting will be accepted which weighs less than 95 percent of the design weight. Shop drawings must indicate the design weight and provide sufficient dimensions to permit checking.
  2. Manhole frames and covers shall be as shown on the Standard Details.
  3. All frames and covers shall have machined horizontal bearing surfaces.
  4. All manholes shall have standard frames and covers except where specifically shown otherwise on the Drawings.
  5. Watertight covers shall be bolt-down type and shall be equipped with four 1/2-inch stainless steel bolts and a 1/8-inch red rubber or rubber O-ring gasket. Covers shall be rotatable and interchangeable. Bolt holes shall be bored through so that debris entering the bolt hole will fall into the manhole. Bolt holes shall have the full 360 degree circle within the cover's radius when bored through the cover.

- J. Boots: Provide preformed rubber boots and fasteners equal to those manufactured by Kor-N-Seal or Press Seal Gasket Corporation. Boots may be mechanically attached to the manhole or cast into the walls of the manhole.

## 2.07 MISCELLANEOUS

A. Flexible Adapter Couplings:

1. Couplings for pipe sizes 15-inches in diameter and less shall be elastomeric plastic sleeves designed to connect pipes of dissimilar materials. Adapters shall provide a positive seal against infiltration and exfiltration and remain leakproof and rootproof up to 4.3 psi. The adapter manufacturer shall provide all stainless steel clamps and required accessories.
2. Couplings shall be products equal to Fernco and shall be installed in accordance with the manufacturer's recommendations.

B. Inside Drop Connections:

1. Where a sewer entering an existing manhole is more than 24-inches above the manhole invert, an inside drop inlet shall be constructed to lower the inlet elevation of the sewer to coincide with the invert elevation of the manhole. If required, the manhole invert and bench shall be re-built in conjunction with the installation of the drop connection to ensure a smooth flow path for the incoming sewer drop. The inside drop connection shall be field fabricated with Schedule 80 PVC fittings and piping, or may be shop fabricated with different materials by a specialty manufacturer subject to approval by the Engineer (e.g. molded polyethylene inside drop inlet by GU International). The top fitting of the inside drop connection shall be a tee fitting or a 90-degree bend with a clean out attachment at the opposite end of the incoming flow opening (to facilitate future sewer inspection and/or cleaning). The bottom fitting of the drop shall be a 90-degree bend into the manhole invert, or a plain end may be used where a concrete fillet is constructed to transition flow from the plain end into the manhole invert. All pipe to manhole connections must conform to ASTM C923. Anchor straps and bolts shall be 304 stainless steel, minimum, with 4 vertical feet maximum spacing (2 straps minimum).

C. Chemical Root Treatment:

1. Chemical Root treatment shall be utilized where indicated to kill invasive roots and to prevent root re-growth in small diameter sewers. Chemical treatment shall be non-carcinogenic, herbicidal type and applied by professional applicator personnel licensed by the Georgia Department of Agriculture. The applicator shall have a minimum of one year experience and having successfully treated a minimum of one hundred thousand lineal feet of sewer main piping in the continental United States of America.
2. Preconditioning or cleaning of the sewer main shall not be required before or after application of chemical root control unless specifically indicated by the Engineer (e.g. to remove large blockages or debris, which may be surcharging the sewer). Root masses do not generally require cutting by mechanical means prior to application of chemical root treatment and shall not be performed unless directed by the Engineer. In such an event, the contractor shall coordinate root cutting with application of the chemical root treatment in accordance with the manufacturer recommendations to meet the desired level of performance stated below.
3. Each treatment application shall progress from the downstream manhole (whenever practical) at such a rate and pressure so as to provide full chemical contact of the entire interior surface of the sewer main while providing penetration of all piping joints, cracks, holes and service connections. The retention time and concentration of the chemical shall be sufficient to kill all roots in the sewer and prevent root re-growth for a period of two years after the application. If re-growth is evident prior to expiration of the aforementioned two-year period, the Contractor shall provide additional chemical root treatment to the satisfaction of the City at no additional cost.
4. Acceptable products are diquat based herbicides equal to those manufactured by Dukes Root Control, Inc.

**PART 3 – EXECUTION**

**3.01 EXISTING UTILITIES AND OBSTRUCTIONS**

- A. The Contractor shall call the Utilities Protection Center (UPC) (1-800-282-7411) as required by Georgia law (O.C.G.A. §§25-9-1 through 25-9-13) and all utilities, agencies or departments that own and/or operate

utilities in the vicinity of the construction work site, at least 72 hours (three business days) prior to construction, to verify the location of the existing utilities.

B. Existing Utility Location: The following steps shall be exercised to avoid interruption of existing utility service.

1. Provide the required notice to the utility owners and allow them to locate their facilities according to Georgia law. Field utility locations are valid for only ten days after original notice. The Contractor shall ensure, at the time of any excavation that a valid utility location exists at the point of excavation.
2. Expose the facility to verify its true location and grade for a distance of at least 200 feet in advance of pipeline construction to verify its true location and grade. Repair, or have repaired, any damage to utilities resulting from locating or exposing their true location.
3. Avoid utility damage and interruption by protecting it with means or methods recommended by the utility owner.
4. Maintain a log identifying when phone calls were made, who was called, area for which utility relocation was requested and work order number issued, if any. The Contractor shall provide the Engineer an updated copy of the log bi-weekly, or more frequently if required.

C. Conflict with Existing Utilities:

1. Horizontal Conflict: Horizontal conflict shall be defined as when the actual horizontal separation between a utility, main, or service and the proposed water main does not permit safe installation of the sewer by the use of sheeting, shoring, tying-back, supporting, or temporarily suspending service of the parallel or crossing facility. The Contractor may change the proposed alignment of the sewer to avoid horizontal conflicts if the new alignment remains within the available right-of-way or easement and complies with regulatory agency requirements after a written request to and subsequent approval by the Engineer. Where the Engineer does not approve such relocation of the sewer, the Contractor shall arrange to have the utility, main, or service relocated.
2. Vertical Conflict: Vertical conflict shall be defined as when the actual vertical separation between a utility, main, or service and the proposed sewer does not permit the crossing without immediate or potential future damage to the utility, main, service, or the sewer. The Contractor may change the proposed grade of the sewer to

avoid vertical conflicts if the changed grade provides minimum required capacity, maintains adequate cover and complies with regulatory agencies requirements, after written request to and subsequent approval by the Engineer. Where the Engineer does not approve such relocation of the sewer, the Contractor shall arrange to have the utility, main, or service relocated.

- D. Electronic Locator: Have available at all times an electronic pipe locator and a magnetic locator, in good working order, to aid in locating existing pipe lines or other obstructions.
- E. Water and Sewer Separation:
  - 1. Sewers should maintain a minimum 10-foot edge-to-edge separation from water mains. Where the sewer crosses a water main, an 18-inch vertical separation shall be maintained where possible. Where possible, a full joint of sewer pipe shall be centered over the water main. Any deviation shall be requested in writing to the Engineer.
  - 2. No water main shall be permitted to pass through or come in contact with any part of a manhole.
- F. Installation: The covers of all manholes shall be at least 30" above grade after installation, except in grassed/landscaped or paved areas. After completion of the manhole survey, the contractor shall submit finish grades of all manhole covers and submit with shop drawings.
- G. Rock Excavation: When rock is encountered in trenches, it shall be removed to a depth of at least six inches (6") below the pipe bell, and a width of three inches (3") on each side of the pipe bell, except for a minimum required trench width of twenty-four inches (24"). Refer to Section 02200 for rock classification and measurement.

### **3.02 CONSTRUCTION ALONG HIGHWAYS, STREETS AND ROADWAYS**

- A. Refer to Specifications Section 01500 – Construction Facilities and Temporary Controls for requirements

### **3.03 PIPE DISTRIBUTION**

- A. Pipe shall be distributed and placed in such a manner that will not interfere with traffic.
- B. No pipe shall be strung further along the route than 1,000 feet beyond the area in which the Contractor is actually working without written permission

from the City. The City reserves the right to reduce this distance to a maximum distance of 200 feet in residential and commercial areas based on the effects of the distribution to the adjacent property owners.

- C. No street or roadway may be closed for unloading of pipe without first obtaining permission from the proper authorities. The Contractor shall furnish and maintain proper warning signs and obstruction lights for the protection of traffic along highways, streets and roadways upon which pipe is distributed.
- D. No distributed pipe shall be placed inside drainage ditches.
- E. Distributed pipe shall be placed as far as possible from the roadway pavement, but no closer than five feet from the roadway pavement, as measured edge-to-edge.

### **3.04 LOCATION AND GRADE**

- A. The slope shown on a pipeline profile and/or called for in the Specifications is the slope of the invert of the pipe.
- B. Prior to clearing and grubbing, construction staking shall be performed.
- C. Construction shall begin at the low end of the sewer and proceed upstream without interruption. Multiple construction sites shall not be permitted without written authorization from the Engineer for each site. At a minimum, cut sheets between construction sites shall be submitted and approved before multiple construction sites will be permitted.
- D. The Contractor shall be responsible for any damage done to reference points, base lines, center lines and temporary bench marks, and shall be responsible for the cost of re-establishment of reference points, base lines, center lines and temporary bench marks as a result of the operations.

### **3.05 LAYING AND JOINTING PIPE AND ACCESSORIES**

- A. Lay all pipe and fittings to accurately conform to the lines and grades established by the Engineer.
- B. Pipe Installation:
  - 1. Proper implements, tools and facilities shall be provided for the safe performance of the Work. All pipe, fittings and valves shall be lowered carefully into the trench by means of slings, ropes or other suitable tools or equipment in such a manner as to prevent damage to sewer materials and protective coatings and linings. Under no

circumstances shall sewer materials be dropped or dumped into the trench.

2. All pipe, fittings and appurtenances shall be examined carefully for damage and other defects immediately before installation. Defective materials shall be marked and held for inspection by the Engineer, who may prescribe corrective repairs or reject the materials.
3. All lumps, blisters and excess coating shall be removed from the socket and plain ends of each pipe, and the outside of the plain end and the inside of the bell shall be wiped clean and dry and free from dirt, sand, grit or any foreign materials before the pipe is laid. No pipe that contains dirt shall be laid.
4. Foreign material shall be prevented from entering the pipe while it is being placed in the trench. No debris, tools, clothing or other materials shall be placed in the pipe at any time.
5. As each length of pipe is placed in the trench, the joint shall be assembled and the pipe brought to correct line and grade. The pipe shall be secured in place with approved backfill material.
6. It is common practice to lay pipe with the bells facing the direction in which work is progressing; however, it is not mandatory.
7. Applying pressure to the top of the pipe, such as with a backhoe bucket, to lower the pipe to the proper elevation or grade shall not be permitted.
8. Polyethylene Encasement: For Ductile Iron Pipe, installation of encasement, when directed by the Engineer, shall be in accordance with AWWA C105 and the manufacturer's instructions. All ends shall be securely closed with tape and all damaged areas shall be completely repaired to the satisfaction of the Engineer.

C. Alignment and Gradient:

1. Lay pipe straight in alignment and gradient or follow true curves, where shown on the Drawings, as nearly as practicable. Do not deflect any joint more than the maximum deflection recommended by the manufacturer.
2. Maintain a transit, level and accessories on the job to lie out angles and ensure that deflection allowances are not exceeded.

3. The Contractor shall check the invert elevation at each manhole and the pipe invert elevation at each bell in open cut areas of pipe installation
  4. The Contractor shall check the horizontal alignment of the sewer and ground surface elevations at the same schedule as for invert elevations.
- D. Expediting of Work: Excavate, lay the pipe, and backfill as closely together as possible, as determined by the Engineer. Do not leave unjointed pipe in the trench overnight. Backfill and compact the trench as soon as possible after laying and jointing is completed. Cover the exposed end of the installed pipe each day at the close of work and at all other times when work is not in progress. If necessary to backfill over the end of an uncompleted pipe or accessory, close the end with a suitable plug, either push-on, mechanical joint, restrained joint or as approved by the Engineer.
- E. Joint Assembly:
1. Joints shall be assembled in accordance with the manufacturer's recommendations.
  2. The Contractor shall internally inspect each pipe joint to insure proper assembly for pipe 30-inches in diameter and larger after the pipe has been brought to final alignment.
  3. On reinforced concrete pipe, diameters 30-inches and larger, the Contractor shall fill the voids, on the pipe joint interior, with grout.
- F. Cutting Pipe:
1. Cut ductile iron pipe using an abrasive wheel saw.
  2. Cut PVC/HDPE pipe using a suitable saw.
  3. Remove all burrs and smooth the end before jointing.
  4. The Contractor shall cut DIP pipe and bevel the end, as necessary, to provide the correct length of pipe necessary for installing the fittings, valves, accessories and closure pieces in the correct location. Only push-on or mechanical joint pipe shall be cut. Plastic and HDPE Pipe shall be cut precisely square.



**3.06 SEWER SERVICE CONNECTIONS**

- A. All sewer service connections shall be identified and located prior to pipe installation or replacement. The complete list of service laterals; included relevant footage and diameter of lateral shall be submitted prior to pipe installation or replacement to the Engineer for information. Upon commencement, pipe installation or replacement shall be continuous and without interruption from one manhole to another, except as approved by the Engineer and/or Engineer representative.
- B. After installation or replacement of mainline sewer is complete, but prior to service reconnects, perform a CCTV inspection with a hand held (“Push”) CCTV camera of all service laterals to the edge of right-of-way (ROW) or edge of easement, or as far as is feasible based on configuration or defects of laterals. The inspection shall be performed in the presence of the Engineer and/or Engineer representative. If the Engineer determines that a lateral requires replacement, the service lateral shall be replaced complete from the mainline sewer to the edge of ROW or edge of easement. If directed to do so by the Engineer, install a two-way cleanout at the edge of ROW or easement. The cleanout shall incorporate all appropriate and necessary couplings for a watertight connection to the service lateral piping.
- C. Upon completion of installation of the new mainline sewer pipe, the Contractor shall complete the reconnection of all service laterals on the segment within 24-hours to minimize inconvenience to sewer customers. Exceptions to this requirement apply only to service laterals that will be replaced from the mainline sewer to the edge of ROW or easement. In these cases, services shall be reconnected within a time frame specified by the Engineer at the work site.
- D. All service connections shall be made by core drilling a circular hole through the wall of the existing pipe. The hole size shall be equal to the inside diameter of the connecting piping, free of burrs or rough edges and perpendicular to the existing pipe. Installation of the saddle assembly shall be in accordance with the saddle manufacturer’s recommendations and provide a watertight seal. Pipe branch connection products shall correspond to the sewer main pipe material as indicated below:

<b>Sewer Main Material</b>	<b>Branch Connection Product</b>
Ductile Iron ***	Sewer saddle equal to CB Sewer Saddle manufactured by Romac Industries.
Concrete	Sewer saddle equal to CB Sewer Saddle manufactured by Romac Industries.
Vitrified Clay ***	Sewer saddle equal to CB Sewer Saddle manufactured by Romac Industries.
PVC ***	Flexible type saddle equal to Fernco Flexible

	Tap Saddle.
HDPE	Flexible type saddle equal to Fernco Flexible Tap Saddle or electrofusion saddle equal to Central Plastics Company Electrofusion Branch Saddle.

\*\*\* Wye or Tee fittings shall be used in lieu of the products indicated above if the sewer main piping is installed using open cut trench methods.

- E. Connections to the existing sewer house connection pipe shall be made using sleeved stainless steel flexible couplings. All flexible couplings shall conform to ASTM C 425 and shall be equal to those manufactured by Fernco Inc., DFW Plastics, Inc., or Mission Rubber Company.
- F. In the event a lined pipe is encountered, the host pipe (outer) pipe material shall be used to determine the branch connection product as indicated above.
- G. The slope of the existing service connection (lateral) toward the new pipe shall be maintained at the existing percent slope. Reconstructed service laterals shall be installed at a minimum slope of one percent (1%) or as specified by the Engineer.
- H. For Supplemental Work Not Shown on Plans or Other Work Tables, the work item term “Rehab Lateral” shall refer to the following process:
  1. The contractor shall locate the structure in the field and perform a CCTV inspection in accordance with Section 02752 Internal Sewer Condition Assessment. This item shall be paid under bid item Sewer, Internal Pipe Inspection, Service Lateral, 4” to 6” Diameter - Bid Item 4-I-6010.
  2. The contractor shall review the results of the CCTV inspection with the Engineer and determine the appropriate rehabilitation method, then prosecute the rehabilitation work.

### 3.07 CONSTRUCTION PRACTICES FOR POLYETHYLENE PIPE

- A. Handling of Pipe: Pipe shall be stored on clean, level ground to prevent undue scratching or gouging of the pipe. If the pipe must be stacked for storage, such stacking should be in accordance with the pipe manufacturer’s recommendations. The pipe should be handled in such manner that it is not damaged by being dragged over sharp objects or cut by chokers or lifting equipment.

- B. Repair of Damaged Sections: Segments of pipe having cuts or gouges in excess of 10% of the wall thickness of the pipe shall be cut out and removed. The undamaged portions of the pipe shall be rejoined using the butt fusion joining method.
- C. Pipe Joining: Sections of polyethylene pipe should be joined into continuous lengths on the job site above ground. The joining method shall be performed in strict accordance with the pipe manufacturer's recommendations. The butt fusion equipment used in the joining procedure shall be capable of meeting all conditions recommended by the pipe temperature, alignment, and fusion pressure.
- D. Handling of Fused Pipe: Fused segments of pipe shall be handled so as to avoid damage to the pipe. When lining fused sections of pipe, chains or cable-type chokers should be avoided. Nylon slings are preferred. Care should be exercised to avoid cutting or gouging the pipe.
- E. Trenching and Backfill: All trenching and backfill shall be in accordance with Section 02200 and standard details on the Drawings and as indicated below:
1. Trench Construction: The trench and trench bottom should be constructed in accordance with ASTM D 2321 – Section 7.
  2. Embedment Material: Embedment materials should be Class I, Class II, or Class III materials as defined in ASTM D 2321 – Section 6. The use of Class IV and/or Class V materials for embedment are not recommended and should be allowed only with the approval of the engineer.
  3. Bedding: Bedding of the pipe should be performed in accordance with ASTM D 2321 –Section 8. Compaction should be specified in ASTM D 2321. Deviation from the specified compaction shall be approved by the engineer.
  4. Haunching and Initial Backfill: Haunching and initial backfill should be as specified in ASTM D 2321- Section 9 using Class I, Class II, or Class III materials. Materials used and compaction shall be as specified by the engineer. Compaction 85% Standard Proctor Density must be maintained in unpaved areas. Paved areas will require a higher level of compaction in accordance with the pavement design criteria.

5. Special Conditions: ASTM D 2321 – Section 11.2, Minimum Cover for Load Application, Section 11.3, Use of Compaction Equipment and Section 11.4, Removal of Trench Protection, should apply unless directed otherwise by the engineer.

### 3.08 MANHOLE AND PRECAST CONCRETE PRODUCT CONSTRUCTION

- A. Construct manholes as shown on the Drawings.
- B. Precast Concrete: Handle sections carefully to prevent cracking or chipping. Provide uniform bedding of the bottom section to prevent uneven loading. Install gaskets and joint sealants in accordance with manufacturer's recommendations to produce a watertight structure.
- C. Brick: Bed the bottom and sides of every brick in mortar. Apply a smooth coat of mortar, 3/4-inch thick, on the inside and outside.
- D. Pipe Connections: Seal the connection between the pipe and the manhole as follows:
  1. Pipe 36-Inch Diameter and Less: Connect pipe to manhole utilizing rubber boots.
  2. If rubber boots are damaged, replace Type I boots with a new boot and repair Type II boots by constructing a manhole collar.
  3. If preformed openings must be enlarged or altered, or if new openings must be made in the field, minimize the amount of material removed to provide closely matched surfaces for grouting.
- E. Inverts: Form channels as shown on the Drawings, rounded, and troweled smooth with brick faces exposed. Maintain consistent grade through the invert.
- F. Top Elevations: Build manholes outside of paved areas to 30-inches above finished grade, unless otherwise shown on the Drawings or directed by the Engineer. Build manholes in paved areas to existing grades.
- G. Drop Connections: Replace existing manholes that contain drop connections, where required, with a similar drop connection. Construct drop connections of the same materials as the upstream sewer and in accordance with the details shown on the Drawings.

- H. Frames and Covers: Unless frame and cover is at grade, the frame shall be cast into the cone section. Covers shall be solid, cast-iron, without ventilation holes.
- I. Seal all manhole joints and lift holes, both inside and out, with grout. Between precast sections, this is in addition to joint sealant.

### 3.09 CONCRETE ENCASUREMENT

- A. Provide concrete encasement of pipe when directed by the Engineer or to protect the pipe when any one of the following conditions are encountered:
  - 1. Pipe crosses under a creek;
  - 2. The top of the pipe would have less than 30 inches of ground cover;
  - 3. The trench bottom consists of unstable material.

### 3.10 INSPECTION AND TESTING

- A. Clean and test lines before requesting final acceptance. Where any obstruction is met, clean the sewers by means of rods, swabs, or other instruments. When requested by the Engineer, flush out lines and manholes before final inspection. The costs for inspection and testing shall be included in the unit prices for pipe replacement and point repairs.
- B. Alignment: Pipe lines shall be straight and show a uniform grade between manholes. Correct any discrepancies discovered during inspection.
- C. Watertightness: A watertightness test shall be performed on all new sewers constructed and lined sewers (prior to cutting the liner to reinstate lateral connections) as indicated below. All visible leaks, including those found via television inspection, shall be repaired.
  - 1. Low-Pressure Air Test: Sewer diameters less than or equal to 24-inches.
    - a. Prior to air testing, the section of sewer between manholes shall be thoroughly cleaned and wetted. Immediately after cleaning or while the pipe is water soaked, the sewer shall be tested with low-pressure air. At the Contractor's option, sewers may be tested in lengths between manholes or in short sections (25 feet or less) using inflatable balls pulled through the line from manhole to manhole. Air shall be slowly supplied to the plugged sewer section until internal air

pressure reaches approximately 4.3 psi. After this pressure is reached and the pressure allowed to stabilize (approximately two to five minutes), the pressure may be reduced to 3.5 psi before starting the test. If a 1.0 psi drop does not occur within the test time, then the line has passed the test. If the pressure drops more than 1.0 psi during the test time, the line is presumed to have failed the test, and the Contractor will be required to locate the failure, make necessary repairs, and retest the line. Minimum test time for various pipe sizes and types is as follows:

Nominal Pipe Size, inches	Time (Min/100 feet)	
	VCP, RCP	DIP, PVC, HDPE
6	0.7	5.7
8	1.2	7.6
10	1.5	9.4
12	1.8	11.3
15	2.1	14.2
18	2.4	17.0
21	3.0	19.8
24	3.6	22.8

- b. Required test equipment, including inflatable balls, braces, air hose, air source, timer, rotameter as applicable, cut-off valves, pressure reducing valve, 0-15 psi pressure gauge, 0-5 psi pressure gauge with gradations in 0.1 psi and accuracy of + two percent, shall be provided by the Contractor. Testing equipment shall be equal to Cherne Air-Loc Testing Systems.
- c. The Contractor shall keep records of all tests made. Copy of such records will be given to the Engineer or the City. Such records shall show date, line number and stations, operator, and such other pertinent information as required by the Engineer.
- d. The Contractor is cautioned to observe proper safety precautions in performance of the air testing. It is imperative that plugs be properly secured and that care be exercised in their removal. Every precaution shall be taken to avoid the possibility of over-pressurizing the sewer line.

D. Deflection Test:

1. All PVC pipe gravity sewers.
  - a. Test PVC and gravity sewer for excessive deflection by passing a mandrel through the pipe. Deflection of the pipe shall not exceed ten percent.
  - b. The mandrel size shall be based upon the maximum possible inside diameter for the type of pipe being tested, taking into account the allowable manufacturing tolerances of the pipe. The mandrel shall have an odd number of legs, or vanes, with a quantity of such equal to or greater than nine. The legs of the mandrel shall be permanently attached to the mandrel. A mandrel with variable sizes shall not be allowed. The mandrel shall be constructed of steel, aluminum or other material approved by the Engineer, and shall have sufficient rigidity so the legs of the mandrel will not deform when pulling through a pipe. The mandrel dimensions shall be checked by the Engineer before use by the Contractor.
  - c. Excavate and install properly any section of pipe not passing the test. Re-test until results are satisfactory.
  - d. The test shall be performed twice:
    - 1) Once within the first 30 days of installation
    - 2) Once during final inspection, but no sooner than 30 days after pavement backfill done, at the completion of this contract.

- E. Closed Circuit Television: The interior of the gravity sewers shall be subjected to a televised inspection. The audio/video shall provide an audio description of what is being viewed; provide a continuous running footage indicator between manholes; and be prepared in the presence of the City's representative. Prior to Final Acceptance, the City shall be provided with one copy of the TV inspection report and video showing the entire length of gravity sewer being tested. The report shall contain the condition of pipe, type of pipe, depth, location of services, length, type joint, roundness, and distance between manholes. Any pipe found to be cracked, leaking, misaligned, bellied or otherwise defective shall be removed and replaced. CCTV inspection shall conform to the requirements of Section 02752. The post-installation CCTV inspection shall take place as shortly after completion of each section as is feasible, but in no case more than ten (10) calendar days thereafter. The contractor

is required to submit the post-installation CCTV videos within ten (10) calendar days of completing the rehabilitation of a segment of the sewer.

All costs associated with the CCTV inspection shall be considered incidental to the pipe installation work and shall be included in the unit prices.

F. Manholes:

1. The costs for vacuum testing of lined and new manholes shall be included in the unit price for the manhole work. Prior to testing manholes for watertightness, all liftholes shall be plugged with a non-shrink grout, all joints between precast sections shall be properly sealed and all pipe openings shall be temporarily plugged and properly braced.
2. Vacuum Tests: The manhole, after proper preparation as noted above, shall be vacuum tested prior to or after backfilling. The test head shall be placed at the inside of the top of the cone section and the compression head inflated to 40 psi to affect a seal between the vacuum base and the manhole structure. Connect the vacuum pump to the outlet port with the valve open. A vacuum of 10-inches of mercury shall be drawn and the vacuum pump shut off. With the valves closed, the time shall be measured for the vacuum to drop to 9-inches. The manhole shall pass if the time is greater than that specified in the table below. If the manhole fails the initial test, necessary repairs shall be made with non-shrink grout while the vacuum is still being drawn. Retesting shall proceed until a satisfactory test is obtained. Vacuum testing equipment shall be equal to that as manufactured by P.A. Glazier, Inc.

<b>MINIMUM TEST TIMES FOR VARIOUS MANHOLE DIAMETERS AND DEPTHS</b>			
<i>Depth (feet)</i>	<b>Minimum Test Times with a 4 ft. Diameter</b>	<b>Minimum Test Times with a 5 ft. Diameter</b>	<b>Minimum Test Times with a 6 ft. Diameter</b>
8	20	28	33
10	25	33	41
12	30	39	49
14	35	48	57
16	40	52	67
18	45	59	73
20	50	65	81
22	55	72	89
24	59	78	97
26	64	85	105
28	69	91	113
30	74	98	121



### 3.11 PROTECTION AND RESTORATION OF WORK AREA

- A. General: Return all items and all areas disturbed, directly or indirectly by work under these Specifications, to their original condition or better, as quickly as possible after work is started.
1. The Contractor shall plan, coordinate, and prosecute the work such that disruption to personal property and business is held to a practical minimum.
  2. All construction areas abutting lawns and yards of residential or commercial property shall be restored promptly. Backfilling of underground facilities, ditches, and disturbed areas shall be accomplished on a daily basis as work is completed. Finishing, dressing, and grassing shall be accomplished immediately thereafter, as a continuous operation within each area being constructed and with emphasis placed on completing each individual yard or business frontage. Care shall be taken to provide positive drainage to avoid ponding or concentration of runoff.
  3. Handwork, including raking and smoothing, shall be required to ensure that the removal of roots, sticks, rocks, and other debris is removed in order to provide a neat and pleasing appearance.
  4. The Engineer shall be authorized to stop all work by the Contractor when restoration and cleanup are unsatisfactory and to require appropriate remedial measures.
- B. Man-Made Improvements: Protect, or remove and replace with the Engineer's approval, all fences, walkways, mail boxes, pipe lines, drain culverts, power and telephone lines and cables, property pins and other improvements that may be encountered in the work. Fences crossing the easement shall be gated.
- C. Cultivated Growth: Do not disturb cultivated trees or shrubbery unless approved by the Engineer. Any such trees or shrubbery that must be removed shall be heeled in and replanted under the direction of an experienced nurseryman.
- D. Cutting of Trees: Do not cut trees for the performance of the work except as absolutely necessary. Protect trees that remain in the vicinity of the work from damage from equipment. Do not store spoil from excavation against the trunks. Remove excavated material stored over the root system of trees

within 30 days to allow proper natural watering of the root system. Repair any damaged tree over 3-inches in diameter, not to be removed, under the direction of an experienced nurseryman. All trees and brush that require removal shall be promptly and completely removed from the work area and disposed of by the Contractor. No stumps, woodpiles, or trash piles will be permitted on the work site. The Contractor may chip and grind vegetation and spread over the disturbed area if approved by the City.

E. Disposal of Rubbish: Dispose of all materials cleared and grubbed during the construction of the project in accordance with the applicable codes and rules of the appropriate City of Atlanta, state and federal regulatory agencies. All debris and rubbish from clearing operations shall be removed from site within one (1) week after cutting.

F. Swamps and Other Wetlands:

1. The Contractor shall not construct permanent roadbeds, berms, drainage structures or any other structures that alter the original topographic features within the easement.
2. All temporary construction or alterations to the original topography will incorporate measures to prevent erosion into the surrounding swamp or wetland. All areas within the easement shall be returned to their original topographic condition as soon as possible after work is completed in the area. All materials of construction and other non-native materials shall be disposed by the Contractor.
3. The Contractor shall provide temporary culverts or other drainage structures, as necessary, to permit the free migration of water between portions of a swamp, wetland or stream that may be temporarily divided by construction.
4. The Contractor shall not spread, discharge or dump any fuel oil, gasoline, pesticide, or any other pollutant to adjacent swamps or wetlands.

END OF SECTION

---

**SECTION 02750**

**Wastewater Flow Control**

**PART 1 – GENERAL**

**1.01 SCOPE**

- A. The objective of flow bypass and/or diversion pumping is to:
1. Maintain an efficient and uninterrupted level of service to wastewater collection system users while maintenance or construction operations (including rehabilitation, repair or replacement) are facilitated on the segment or segments being bypassed and/or from which flow is being diverted, within the wastewater collection system
  2. Ensure all levels of sewage flow are continuously and effectively handled around the segment or segments of sewer being bypassed and/or from which flow is being diverted by:
    - a. Ensuring that bypass and diversion pumps are adequately fueled, lubricated and maintained
    - b. Ensuring backup spare parts are expeditiously applied to the flow bypass and/or diversion pumping system in the event of component breakdown
    - c. Ensure an emergency backup plan is smoothly implemented in the event of system failure
    - d. Preventing backup, spillage, flooding or overflow onto streets, yards and unpaved areas or into buildings, adjacent ditches, storm sewers, and waterways, while flow bypass or diversion pumping takes place and ensure that installation, startup and subsequent disassembly of the flow bypass and diversion pumping system is smoothly transitioned
- B. When pumps are operating, an experienced bypass/diversion pump maintenance operator/mechanic and/or assistant shall continuously be on site to monitor the operation of the entire bypass/diversion system. The operator/mechanic and/or assistant shall comprehensively, methodically and continuously:
1. Adjust pump speed as appropriate so as not to adversely impact upstream or downstream flow condition levels

2. Check that the effectiveness and security of bulkheads, dams, diaphragms, plugs, valves, weirs, and all other flow control devices are working effectively and according to plan
  3. Check the integrity of hoses and couplings along the entire bypass/diversion system
  4. Monitor fuel tanks and refuel as necessary
  5. Monitor lubrication levels and provide additional lubrication as
  6. Facilitate minor repairs as required
  7. Report on potential problems arising
  8. Inspect bypass-pumping system at least hourly to ensure that the system is working correctly.
  9. Maintain adequate supply of spare parts on site as required.
- C. Bypass pumping systems shall include a maximum of 600 lineal feet discharge piping length.

## 1.02 SUBMITTALS

- A. The design, installation, and operation of the temporary pumping system shall be the Contractor's responsibility. The Contractor shall employ the services of a vendor that can demonstrate to the Engineer that the vendor specializes in the design and operation of temporary bypass pumping systems. The vendor shall provide at least three (3) references of projects of a similar size and complexity as this project, which were successfully performed by the vendor's firm within the past three years. The reference shall include the name of the agency, the name of the project, the date of the project, and the agency contact (telephone, fax, and e-mail). The bypass system shall meet the requirements of all codes and regulatory agencies having jurisdiction. **(Submit at Pre-Construction Meeting)**
- B. During the course of the project, the detailed, work-specific Bypass Pumping/Flow Diversion Plan for any bypass utilizing multiple pumps, or a single pump greater than 4" discharge, shall be submitted to the Engineer at least 10 days before required. This plan shall outline all provisions and precautions, to be taken by the Contractor, regarding the handling of existing wastewater flows. This plan must be specific and complete, including such items as schedules, locations, elevations, capacities of equipment, materials and all other incidental items necessary and/or required to insure proper protection of the facilities. The Plan shall also

include details of protection of the access and bypass pumping locations from damage due to the discharge flows, compliance with the requirements and permit conditions specified in these Contract Documents. No construction shall begin until all provisions and requirements have been reviewed and authorized by the Engineer.

- C. The Contractor shall submit two copies of the Flow Bypass Pumping/Flow Diversion Plan, described in Item 1.02(B) above, for each sewer bypass set-up with sufficient detail to show:
1. Staging areas for pumps
  2. Sewer plugging method and types of plugs
  3. Number, size, material, location, and method of installation of suction piping
  4. Bypass pump sizes, capacity, number of each size to be on site and power requirements
  5. Calculations for selection of bypass pump size
  6. Standby power generator size, location
  7. Downstream discharge plan
  8. Method of protecting discharge manholes or structures from erosion and damage
  9. Thrust and restraint block sizes and locations
  10. Sections showing suction and discharge pipe depth, embedment, select fill and special backfill where required
  11. Method of noise control for each pump and/or generator
  12. Any temporary pipe supports, including rollers and elevated rollers, as well as anchoring required
  13. Design plans and computation for access to bypass pumping locations indicated on the drawings
  14. Schedule for installation of and maintenance of bypass pumping lines
  15. Plan indicating selection location of bypass pumping line locations

16. The Plan shall indicate the means by which flows from service laterals will be accommodated
- D. All proposed flow control arrangements, including flow bypass and/or diversion pumping plans for sewers, shall also include an emergency response plan to be followed in the event of a failure of the bypass pumping and/or diversion system. Contractor's emergency response plan shall be in accordance with the City's Emergency Response Plan.
- E. The Contractor shall notify the Engineer 24 hours prior to commencing actual flow bypass and/or diversion pumping operations. The Contractor flow control proposal shall be agreed to by the Engineer before the Contractor shall be allowed to commence sewerage bypass pumping and/or diversion.

### **1.03 RELATED SECTIONS**

- A. The Work of the following Sections apply to the Work of this Section. Other Sections of the Specifications, not referenced below, shall also apply to the extent required for proper performance of Work.
  1. Section 02752: Internal Sewer Condition Assessment
  2. Section 02511: Preconditioning and Cleaning Manholes
  3. Section 02725: Pipebursting Method
  4. Section 02491: Rehabilitation of Sanitary Sewer Manholes

### **1.04 RESPONSIBILITY FOR OVERFLOWS OR SPILLS**

- A. It shall be the responsibility of the Contractor to schedule and perform his work in a manner that does not cause or contribute to incidence of overflows or spills of sewage from the sewer system.
- B. In the event of overflows caused by the Contractor's work activities, the Contractor shall immediately take appropriate action in accordance with the City's Emergency Response Plan (ERP), to contain and stop the overflow, clean up the spillage, disinfect the area affected by the spill, and notify the designated Engineer in a timely manner. The Contractor shall prepare his own written Standard Operating Procedure (SOP) for handling and reporting spills, which shall be compatible with the City's ERP.
- C. Contractor will indemnify and hold harmless the City for any fines or third-party claims for personal or property damage arising out of a spill or overflow that is fully or partially the responsibility of the Contractor, including

the legal, engineering and administrative expenses of the City in defending such fines and claims.

## **PART 2 – PRODUCTS**

### **2.01 PUMPING EQUIPMENT**

- A. All pumps used shall be fully automatic self-priming units that do not require the use of foot-valves or vacuum pumps in the priming system. The pumps may be electric or diesel powered. All pumps used must be constructed to allow dry running for long periods of time to accommodate the cyclical nature of effluent flows.
- B. The Contractor shall provide the necessary stop/start controls for each pump.
- C. The Contractor shall include one stand-by pump of each size to be maintained on site for each by pass set up unless otherwise agreed with the Engineer.
- D. The Contractor shall design all piping, joints, and accessories to withstand twice the maximum system pressure or 50 psi, whichever is greater. The back-up pump, appropriate piping, fuel, lubrication and spare parts shall be incorporated into the bypass arrangement at the site, ready for use in case of breakdown. A bypass “drill” shall be carried out by the Engineer before the bypass arrangement is accepted on all sewers > 12” diameter, at no cost to the City. The drill shall demonstrate the incorporation of all standby equipment to handle flows when the main pump set is switched off. The Engineer’s instructions following the drill shall be adhered to in full at no additional cost to the City.
- E. No more than two (2) pump discharge hoses shall be used for the bypass/diversion over the length of the line of segment(s). If the flow exceeds the capacity of 2 “hoses”, then rigid piping shall be used. The rigid piping shall consist of HDPE or steel pipes with suitably pressure rated couplings to withstand twice the maximum system pressure or 50 psi, whichever is greater.
- F. Under no circumstances will aluminum “irrigation” type piping or glued PVC pipe be allowed. Discharge hose will only be allowed in short sections and by specific permission from the Engineer.

### **2.02 SYSTEM DESCRIPTION**

- A. Design Requirements:

1. Bypass pumping systems shall have sufficient capacity to pump a peak flow in the pipes that are being rehabilitated or repaired. The Contractor shall provide all pipeline plugs, pumps of adequate size to handle wet weather peak flows, and temporary discharge piping to ensure that the total flow of the main can be safely diverted around the section to be repaired. Bypass pumping system will be required to be operated 24 hours per day.
2. The Contractor shall have adequate standby equipment available and ready for immediate operation and use in the event of an emergency or breakdown. One standby pump for each size pump utilized shall be installed at the mainline flow bypassing locations, ready for use in the event of primary pump failure.
3. Bypass pumping system shall be capable of bypassing the flow around the work area and of releasing any amount of flow, up to full available flow, into the work area as necessary for satisfactory performances of work.
4. The Contractor shall make all arrangements for bypass pumping during the time when the main is shut down for any reason. System must overcome any existing force main pressure on discharge.

B. Performance Requirements:

1. It is essential to the operation of the existing sewerage system that there is no interruption in the flow of sewage throughout the duration of the project. To this end, the Contractor shall provide, maintain and operate all temporary facilities such as dams, plugs, pumping equipment (both primary and back-up units as required), conduits, all necessary power, and all other labor and equipment necessary to intercept the sewage flow before it reaches the point where it would interfere with his work, carry it past his work, and return it to the existing sewer downstream of his work.
2. The design, installation, and operation of the temporary pumping system shall be the Contractor's responsibility. The bypass system shall be the Contractor's responsibility. The bypass system shall meet the requirements of all codes and regulatory agencies having jurisdiction.
3. The Contractor shall provide all necessary means to safely convey the sewage past the work area. The contractor will not be permitted to stop or impede the main flows under any circumstances.



4. The Contractor shall maintain sewer flow around the work area in a manner that will not cause surcharging of sewers, damage to sewers and that will protect public and private property from damage and flooding.
5. The Contractor shall protect water resources wetlands and other natural resources.

## **PART 3 – EXECUTION**

### **3.01 PLANNING**

- A. The Contractor shall be solely responsible for planning and executing sewer flow control, bypass, and diversion pumping operations. The Contractor shall be entirely liable for damages to private or public property that may result from his operations and for all cleanup, disinfection, damages, and resultant fines in the event of a spillage, flooding or overflow.

### **3.02 GENERAL**

- A. If, during normal rehabilitation work on manholes and sewers, where flow control devices, including flow bypass and diversion pumping have not been deployed, and wastewater flow depth exceeds the workable levels, the rehabilitation work shall be discontinued immediately. Rehabilitation work shall only resume when minimum flow levels prevail– normally between 2:00 am to 5:30 a.m. Under these circumstances, one or more of the following flow control systems shall be deployed at no additional cost to the City:
  1. Plugging or blocking
  2. High-velocity jet nozzles
  3. Bypass and/or diversion pumping
- B. Before any flow control arrangement is installed, the Contractor shall arrange to desilt the segment of sewer to be bypassed while still under flow. Subsequent jetting and final cleaning before rehabilitation or repair shall be undertaken while the segment of sewer is bypassed.
- C. Precautions:
  1. Contractor is responsible for locating any existing utilities in the area the Contractor selects to locate the bypass pipelines. The Contractor shall locate his bypass pipelines to minimize any

disturbances to existing utilities and shall obtain approval of the pipeline locations from the City and the Engineer. All costs associated with relocating utilities and obtaining all approvals shall be paid by the Contractor.

2. During all bypass-pumping operations, the Contractor shall protect mains, manholes, and all local sewer lines from damage caused by any equipment. The Contractor shall be responsible for all physical damage to mains, manholes, and all local sewer lines caused by human or mechanical failure.

### **3.03 PLUGGING OR BLOCKING**

- A. Insert sewer line plug into the line at a manhole upstream from the manhole or sewer that is to be rehabilitated and tested. For manhole rehabilitation, the plug shall be designed so that a portion of the sewage can be released downstream. During this portion of the operation, shut off or substantially reduce flows so that the manhole can be properly cleaned, prepared, and rehabilitated. Flow shall be shut off as required, to properly rehabilitate the manhole or sewer.
- B. Plugging or blocking of sewage flows shall incorporate primary and secondary plugging device. When plugging or blocking is no longer needed for performance and acceptance or work, it is to be removed in a manner that permits the sewage flow to slowly return to normal without surge, to prevent surcharging or causing other major disturbances downstream.

### **3.04 FLOW BYPASS AND/OR DIVERSION PUMPING SCHEDULING**

- A. If the City is operating or maintaining conventional pumping facilities and/or flow bypass and/or diversion pumping in the construction area of the present Contract, the Contractor shall coordinate with the City as necessary to determine and effect optimum working arrangements.
- B. The Contractor shall immediately cease bypass and/or diversion pumping when so ordered by the City.

### **3.05 ENVIRONMENTAL PROTECTION MEASURES**

- A. During flow bypass and/or diversion pumping, the Contractor is prohibited from allowing any sewage to be dumped, or spilled in or onto the ground or any area outside of the existing wastewater collection system. In addition, due care and attention shall be given to prevent vehicular or pump fuel or lubrication oil to be leaked.

### **3.06 PIPE RESIDUE**

- A. When flow bypass and diversion pumping operations are complete, the residual contents of sewage in piping shall be drained into the existing sewer prior to disassembly.

END OF SECTION

(This page is intentionally blank)

---

**SECTION 02752****Internal Sewer Condition Assessment****PART 1 – GENERAL****1.01 SCOPE**

- A. It is the intent of this contract to assess the internal structural and service condition of sewers prior to preconditioning or rehabilitation. Assessment will be performed using pan and tilt color camera-CCTV. In those circumstances where depth of flow is too great for CCTV, sonar or a combination of sonar and CCTV shall be used.
- B. It is also the intent of this contract to inspect individual sewer lines that have been preconditioned to further assess condition and record findings.
- C. It is the responsibility of the Contractor to comply with OSHA regulations, the City of Atlanta’s Safety Guidelines, and the City of Atlanta’s Confined Space Guidelines as applicable. The Contractor shall provide written documentation that all workers have received the training required under these regulations and guidelines.
- D. The form of internal condition assessment that is required as part of this Contract as follows:
  - 1. Sewer inspection – Viewing the sewer (“pull-through”) pursuant to investigative work possibly incorporating a radio-sonde transmitter for locating purposes and/or following other operational activity including:
    - a. Locating manhole(s) and/or lateral(s) with or without radio-sonde
    - b. Sewer preconditioning and cleaning activities
    - c. Sewer rehabilitation, including point repairs
    - d. Such other similar purposes as may be required by the engineer
    - e. Sewer inspection shall be carried out manually or with the aid of CCTV and/or sonar equipment, to assess overall condition. No detailed data logging is required, but a report containing header information only is required.
  - 3. Service lateral inspection – Assess and document the internal condition of all Connections and Junctions pursuant to investigative work and/or following other operational activity including:

- a. Locating lateral(s) with or without radio-sonde
- b. Sewer preconditioning and cleaning activities
- c. Service lateral rehabilitation, including point repairs
- d. Such other similar purposes as may be required by the Engineer
- e. Service lateral inspection shall be carried out manually or with the aid of CCTV and/or Sonar equipment, if required by one of the four conditions above, to assess overall condition. No detailed data logging is required, but a report containing header information only is required.

**1.02 SUBMITTALS**

- A. The Contractor shall provide to the Engineer the following information in writing prior to the set deadline, or at the indicated frequency, whichever is applicable.

<u>Type of Submittal</u>	<u>Time/Frequency of Submittal</u>
Experience Record of Contractor and/or Subcontractor(s)	<b>With the Bid Documents</b>
Listing of CCTV and SONAR Equipment	Before the Work Begins
2 Copies of CCTV and SONAR findings (2 hard copies of fully detailed logs incorporating a summary statistical breakdown of defects and main findings, 2 electronic discs of fully detailed logs and CD-ROMS of video output)	One week After Completion of Section
Daily Logs and Progress Reports	Daily
Confined Space Entry Logs	Bi-Weekly

- B. Daily reports shall be provided via e-mail to the designated engineer. Daily reports shall be provided no later than 5:00PM on the second day following the survey. Weekly reports shall be provided no later than 5:00PM on the first Monday following the week of the survey.

- C. The Contractor shall complete a daily written record (diary) detailing the work carried out and any small items of work which were incidental to the contract. The Contractor shall include in his daily record, reference to:

- 1. Delays: e.g. Dense traffic, lack of information, sickness, labor or equipment shortage

2. Weather: conditions, e.g. rain, etc.
  3. Equipment: on site, e.g. specialist cleaning, by-pass equipment, etc.
  4. Submittals: to the designated engineer representative
  5. Personnel: on site by name, e.g., all labor, Specialist Services, etc.
  6. Accident: report, e.g. all injuries, vehicles, etc.
  7. Incident: report, e.g. damage to property, property owner complaint, etc.
  8. Major defects encountered, including collapsed pipe, if any: e.g. cave-ins, sink holes, etc.
  9. Visitors: on site
- D. The designated Engineer on site shall certify receipt of the daily record noting any items and adding any observations with reference to claims for payment to the Contractor. The Engineer may at his discretion, for which the Contractor must receive direction in writing, an exception to this requirement for weekly submission of progress rather than for daily submission.

### **1.03 REQUIREMENTS AND EXTENT OF INSPECTION**

- A. The Contractor shall inspect pipelines with color pan and tilt CCTV imagery and sonar and or combined color pan and tilt CCTV/Sonar (TISCIT) as specified so as to record all relevant features and to confirm their structural and service condition. Inspections of pipelines shall be carried out in accordance with the reporting format determined by the Engineer. A sample report sheet is attached to this specification (Attachment B) and includes the recording of both target total length of sewer inspected between manholes as well as actual length inspected.
- B. All CCTV/sonar operator(s) responsible for direct reporting of sewer condition shall have a minimum of 3 years previous experience in surveying, processing, and interpretation of data associated with CCTV and sonar inspections. The Contractor shall provide the designated Engineer with written documentation that all CCTV and sonar survey operators meet these experience requirements which shall include a list of projects undertaken as well as client name and telephone number for reference.
- C. All approved Contractors will be required to provide certification that they have undergone training prior to undertaking internal condition assessment work in the City of Atlanta. Material, Shape and Lining Coding used throughout the project will conform to the attached listing (Attachment C). General inspection logging requirements are also included with this Section

(Attachment D). Training will be carried out at the Contractor expense. No charge will be levied for the training, which is expected to last two days.

- D. The Contractor shall complete a daily written record (diary) detailing the work carried out and any small items of work which were incidental to the Contract.

#### **1.04 INSPECTION UNITS**

- A. The Contractor shall provide sufficient inspection units and all relevant ancillary equipment, including standby units in the event of breakdown, in order to complete all sewer and manhole inspections as specified.

#### **1.05 INSPECTION VEHICLE**

- A. The inspection vehicle shall comprise two totally separate areas. One of these, designated as the viewing area, shall be insulated against noise and extremes in temperature, include the provision for air conditioning, and shall be provided with means of controlling external and internal sources of light in a manner capable of ensuring that the monitor screen display is in accordance with the specification. Seating accommodation shall be provided by the Contractor to enable two people, in addition to the operator, to view clearly the on-site monitor, which shall display the inspection as it proceeds.
- B. The working area shall be reserved for equipment, both operational and stored, and no equipment utilized within the sewer shall be allowed to be stored in the viewing area.
- C. The Contractor shall allow in the rates and provide at no additional cost, a vehicle when required by the City, together with a driver, to assist with visual reconnaissance surveys and/or inspections. The vehicle shall be suitable for carrying the survey team and laborers and shall be equipped with the following:
  - 1. Equipment for easing and lifting manhole covers.
  - 2. Sewer safety equipment.
  - 3. Road safety equipment.
  - 4. Protective clothing for the survey/inspection teams comprising coveralls, boots, gloves, hard hat etc.

#### **1.06 CCTV INSPECTION AND OPERATIONAL EQUIPMENT REQUIREMENTS**

- A. The inspecting equipment shall be capable of inspecting a length of sewer up to at least 1500 ft. when entry onto the sewer may be obtained at each



end and up to 100 ft. by rodding or up to 750 ft. where a self propelled unit is used, where entry is possible at one end only. The Contractor shall maintain this equipment in full working order and shall satisfy the designated Engineer at the commencement of each working shift that all items of equipment have been provided and are in full working order.

- B. Each inspection unit shall contain a means of transporting the CCTV camera and/or sonar equipment in a stable condition through the sewer under survey and/or inspection. Such equipment shall ensure the maintained location of the CCTV camera or sonar equipment when used independently on or near to the central axis of a circular shaped sewer when required in the prime position.
- C. Where the CCTV camera and/or Sonar head are towed by winch and bond through the sewer, all winches shall be stable with either lockable or ratcheted drums. All bonds shall be steel or of an equally non-elastic material to ensure the smooth and steady progress of the CCTV camera and/or Sonar equipment. All winches shall be inherently stable under loaded conditions.
- D. Each unit shall carry sufficient numbers of guides and rollers such that, when surveying or inspecting, all bonds are supported away from pipe and manhole structures and all CCTV/Sonar cables and/or lines used to measure the CCTV camera's/sonar head location within the sewer are maintained in a taut manner and set at right angles where possible, to run through or over the measuring equipment.
- E. Each unit shall carry a range of flow control plugs or diaphragms for use in controlling the flow during the inspection. A minimum of one item of each size of plug or diaphragm ranging from 6 inches to 2 feet diameter inclusive shall be carried.
- F. Each inspection unit shall have on call equipment available to carry out the flushing, rodding and jetting of sewers as and when such procedures are deemed to be necessary.

#### **1.07 FIELD SUPERVISION BY CONTRACTOR**

- A. The Contractor shall maintain on site at all times a competent field supervisor in charge of the inspection, see item 3.1 below. The field supervisor shall be approved in writing by the designated Engineer prior to commencement of Work. Any change of supervision must also be approved in writing by the designated Engineer prior to the change. The field supervisor shall be responsible for the safety of all site workers and site conditions as well as ensuring that all work is conducted in conformance with these specifications and to the level of quality specified.

## **1.08 APPLICATION OF INSPECTION TYPE**

- A. The following guidelines concerning the use of CCTV and sonar shall be followed, subject to the review and approval of the designated Engineer:
1. Generally CCTV alone shall be used for internal condition assessment where the depth of flow of sewage is less than 25% of overall sewer diameter at the start of the survey. The Contractor will make an informed decision to continue should the depth of flow increase beyond the 25% level but no greater than 40% of overall sewer diameter at any time throughout the length.
  2. Generally CCTV combined with sonar shall be used for internal condition assessment where depth of flow of sewage varies from 25% to 75% of overall sewer diameter for sewers greater than 24-inches in diameter. Where the sewer is less than 24-inches in diameter and depth of flow of sewage exceeds 25% and is less than 75% of overall sewer diameter the designated Engineer shall instruct Contractor to either: (a) continue using CCTV (where depth of flow is only marginally greater than 25% of overall diameter) or (b) use sonar (by damming or plugging the sewer so that depth of flow exceeds 75% of overall diameter).
  3. Generally sonar alone shall be used where depth of flow in the sewer exceeds 75% of overall diameter and the level of the flow will be artificially increased, without the risk of flooding, to ensure that the pipe is completely surcharged.

## **PART 2 – PRODUCTS (Not Used)**

## **PART 3 – EXECUTION**

### **3.01 CLEANING PRIOR TO INTERNAL CONDITION INSPECTION**

- A. Where required by the City and only when instructed in writing, the Contractor shall clean the sewer prior to internal condition inspection. Cleaning shall be carried out in conformance with Section 02511 – Preconditioning and Cleaning of Manholes and Sewers.

### **3.02 SEWER CLEANING UNITS AND EQUIPMENT**

- A. The Contractor shall provide sufficient sewer cleaning units and equipment, including standby units in the event of breakdown, in order to complete cleaning operations as specified.

### 3.03 CCTV/SONAR – GENERAL

- A. CCTV Camera/Sonar Head Prime Position: The CCTV camera/sonar head shall be positioned to reduce the risk of picture distortion. In circular sewers the CCTV camera lens and/or sonar head shall be positioned centrally (i.e. in prime position) within the sewer. In non- circular sewers, picture orientation shall be taken at mid-height, unless otherwise agreed, and centered horizontally. In all instances the camera lens/sonar head shall be positioned looking along the axis of the sewer when in prime position. A positioning tolerance of  $\pm 10\%$  of the vertical sewer dimension shall be allowed when the camera is in prime position.
- B. CCTV Camera/Sonar Head Speed: The speed of the CCTV camera in the sewer shall be limited to 8 inches per second for surveys to enable all details to be extracted from the ultimate CD-ROM recording. Similar or slightly higher speed as agreed by the designated Engineer shall be provided for inspections. The speed of scanning sonar shall be limited to 4 inches per second.
- C. CCTV Color Camera: The Contractor shall provide a color pan and tilt camera(s) to facilitate the survey and inspection of all laterals, including defects such as hydrogen sulfide corrosion in the soffit of sewers and benching or walls of manholes over and above the standard defects that require reporting, where required by the designated Engineer. These will be carried out as part of the normal CCTV assessment as the survey or inspection proceeds when instructed by the designated Engineer. A 360° rotational scan indicating general condition must be implemented at every 50 feet interval (min.) along sewers, and at manholes and any salient, specified, defect features. The tilt arc must not be less than 225°.
- D. Linear Measurement:
  - 1. The CCTV/Sonar monitor display shall incorporate an automatically updated record in feet and tenths of a foot of the footage of the camera or center point of the transducer, whichever unit is being metered, from the cable calibration point. The relative positions of the two center points should also be noted.
  - 2. The Contractor shall use a suitable metering device, which enables the cable length to be accurately measured; this shall be accurate to  $\pm 1\%$  or 3 inches whichever is the greater.
  - 3. The Contractor shall demonstrate compliance with the tolerance in Sub-clause 3.7 D.2 is being complied with, using one or both of the following methods in conjunction with a linear measurement audit form which shall be completed each day during the survey:
    - a. Use of a cable calibration device

b. Tape measurement of the surface between manholes

A quality control form will be completed and submitted by the Contractor depicting the level of accuracy achieved.

4. If the Contractor fails to meet the required standard of accuracy, the designated Engineer shall instruct the Contractor to provide a new device to measure the footage. The designated Engineer retains the right to instruct the Contractor in writing, to re-survey those lengths of sewer first inspected with the original measuring device using the new measuring device.

E. Data Display, Recording and Start of Inspection:

1. At the start of each sewer length being inspected and each reverse set-up, the length of pipeline from zero footage, the entrance to the pipe, up to the cable calibration point shall be recorded and reported in order to obtain a full record of the sewer length. Only one survey shall be indicated in the final report. All reverse set-ups, blind manholes, and buried manholes shall be logged on a separate log. Video digits shall be recorded so that every recorded feature has a correct tape elapsed time stamp. Each log shall make reference to a start (ST) and finish (FH) manhole unless abandonment took place because of blockage. Manhole number shall be indicated in the remark's column of the detail report. Inspections must not extend over 2 CD-ROMs.
2. The footage reading entered on to the data display at the cable calibration point must allow for the distance from the start of the inspection to the cable calibration point such that the footage at the start of the survey is zero.
3. In the case of inspecting through a manhole where a new header sheet must be completed, the footage shall be set at zero with the camera focused on the outgoing pipe entrance.
4. At the start of each manhole length a data generator shall electronically generate and clearly display on the viewing monitor and subsequently on the CD-ROM recording a record of data in alpha-numeric form containing the following minimum information:
  - a. Automatic update of the camera's footage position in the sewer line from adjusted zero
  - b. Sewer dimensions
  - c. Manhole/pipe length reference numbers
  - d. Date of inspection

- e. Road name/location
  - f. Direction of inspection
  - g. Time of start of inspection
  - h. Sewer use (S-Sanitary Sewer, C-Combined Sewer, etc)
  - i. Material of construction of the pipe
5. The size and position of the data display shall be such as not to interfere with the main subject of the picture.
  6. Once the survey of the pipeline is under way, the following minimum information shall be continually displayed:
    - a. Automatic update of the camera's footage position in the sewer line from adjusted zero (see Sub-clause A4)
    - b. Sewer dimensions in inches
    - c. Manhole or pipe length reference number (PLR). General convention allows upstream manhole number to be designated PLR
    - d. Direction of survey, i.e., downstream or upstream
  7. Correct adjustment of the recording apparatus and monitor shall be demonstrated by use of the test tape or other device approved by the Contractor. Satisfactory performance of the camera shall be demonstrated by the recording of the appropriate test device at the commencement of each day for a minimum period of 30 seconds.
  8. Footage and corresponding time elapsed video digit shall be given throughout inspection for all construction features encountered unless otherwise agreed.
  9. Where silt encountered is greater than 10 percent of the diameter of the pipe, the depth of silt shall be measured and recorded at approximately 50-foot intervals.
  10. CD-ROM capacity shall be adequate to record two hours of video inspection. Recording of a single segment shall not extend over more than one CD-ROM. No unrecorded gaps shall be left in the recording of a segment between surveys/inspections as the original video tape.
  11. Only segments between manholes on the same sewer reach or basin shall be included on one CD-ROM. There shall be no “split surveys” or “split-basins” between CD-ROMs.

12. All continuous defects shall incorporate a start and finish abbreviation in the log report
- F. Coding: Material, Shape, and Lining Coding, and conventions used throughout the project will be provided by the designated Engineer. See Attachments to this Section. The CCTV Contractor must ensure that all operators conform to the detailed requirements of the reporting procedure concerning feature description and feature definition as well as the Sewer1.Dat computer file format attached. An example Sewer1.Dat Data File has also been provided in Attachment E.

### 3.04 CCTV AND SONAR SURVEY DATA SPECIFICATION

A. CCTV Reporting:

1. No later than fourteen days following the completion of a pipeline inspection, Contractor shall submit to the Engineer two hard copies of all details, i.e. typed “Full English” reports including two floppy diskettes containing the data transfer file and two CD-ROM’s shall be submitted to the designated Engineer. The supplied data and information shall remain the property of the City.
2. The report shall be computer validated using AMPS/EXAMINER software, or equivalent approved by the designated Engineer, and presented on two floppy diskettes to provide a summary listing of the number and type of features including defects found for each section of pipeline. The report format is shown in the attached specimen report. This specimen report sheet shall be accurately and fully adopted in style, format and in detail.
3. When requested, the Contractor shall provide hard copy output or manually completed site coding sheets at the time of the inspection and shall forward copies of these sheets to the designated Engineer, preferably each day, but at least every other day, together with a daily report on progress.
4. Inspection reports shall contain all header information. A summary observation shall be included as a comment in the header indicating the general condition of the segment for which the inspection was required. The detailed section of the report will include coding for the for the start (ST), manhole (MH), water level (WL), finish manhole (MH) where appropriate, and finish (FH) or survey abandoned (SA) as appropriate, together with all the supplemental information otherwise required for the “survey”.

- B. Site Coding Sheets: Each sewer length, i.e. the length of sewer between two consecutive manholes, shall be entered on a separate coding sheet or entered separately electronically. Thus where a Contractor elects to "pull

through" a manhole during a CCTV and/or Sonar inspection a new coding sheet shall be started at the manhole "pulled or walked through" and the footage re-set to zero on the coding sheet. Where a length of sewer between consecutive manholes is inspected from each end (due to an obstruction) two coding sheets should be used. Where a length of sewer between two consecutive manholes cannot be inspected or attempted for practical reasons a (complete header) coded sheet shall be made out defining the reason for abandonment. At uncharted manholes a new coding sheet must be started and the footage re-set to zero.

C. Measurement Units: All dimensions shall be in feet and inches. Measurement of sewers shall be to the nearest inch.

D. CCTV Photographs:

1. Photographs shall be taken of all defective laterals and pipeline defects where requested in writing. Where a defect is continuous or repeated the photographs shall be taken at the beginning of the defect and at not less than 10 foot intervals thereafter. Where photographs are not otherwise required a general condition photograph shall be taken not more than 50 feet after the previous photograph.
2. CCTV Photographs must clearly and accurately show what is displayed on the monitor, which shall be in proper adjustment.
3. Photographs must be durable and 3"x5" size and shall be supplied in a suitable album or storage drawer the standard of which shall be to the satisfaction of the designated Engineer.
4. Still photographs shall be durable and clearly identified in relation to the photograph number (cross referenced to the site survey sheet) street location, sewer dimensions, manhole start and finish numbers, survey direction, footage and date when the photograph was taken.
5. The annotation shall be clearly visible and in contrast to its background, shall have a figure size no greater than 14 point, and be type printed in upper case.
6. The annotation shall be positioned so as not to interfere with the subject of the photograph.
7. The Contractor shall provide color photographs using digital camera or such other mutually agreed upon hard copy color image together with electronic copy.

E. Control Sample Photographs and/or CD-ROMs: The designated Engineer may issue a written instruction to the Contractor to provide a sample of the

photographs and/or CCTV/Sonar video taken during the contract period which the Contractor shall provide within 5 working days of receiving the written instruction.

### 3.05 SERVICE LATERAL INSPECTION DATA SPECIFICATION

- A. For service line inspections launched from the mainline during a mainline inspection:
1. Contractors will assess and document the internal condition of all Connections and Junctions using the previously described procedures, with the exception of ending abandoned service line inspections launched from the mainline. Use “GOA” to note abandonment.
  2. A number will be entered into the “Photo No.” field that represents a sequential numbering of the services found. The services will be numbered 01, 02, 03, etc. When the inspection is a reverse setup and the number of services has not exceeded 50, the numbering shall begin with 51 on the reverse. (It is unlikely that there will be more than 50 services on the first survey that is abandoned, however, should this occur, numbering shall continue on the reverse with the same sequence begun on the first survey.)
  3. The end of the inspection of the service line at the property line shall be entered “GO” (General Observation code), along with the service line number in the “Photo No.” column, and the distance to the end of the survey in the “Remarks” column. The “Distance” will also be the same as for the Connection or Junction. When a survey is abandoned, the code “GOA” shall be used and the reason for the abandonment stated in the “Remarks” column.
  4. Measurements shall be taken from the wall of the mainline pipe.
- B. For service line inspections conducted from a cleanout (or as a separate inspection launched from the mainline), the inspection shall be recorded as a normal mainline inspection with the following exceptions:
1. When the mainline is inspected or surveyed, all services shall be numbered using a number in the “Photo No.” field, as explained above.
  2. The “Start Manhole” shall be entered as the upstream manhole followed by “\_01”, “\_02”, etc. Where the “\_01” corresponds to the service number assigned when the mainline was surveyed.
  3. The upstream manhole shall be entered as the PLR.



4. The “Address” shall be the address of the house connected by the service line.
5. If the inspection begins at a cleanout, the “Direction” is entered as “D”. If the inspection begins from the mainline, the “Direction” is entered as “U”.
6. “=Service Line=” shall be entered in the “Location Details” field.

### 3.06 CCTV/SONAR PERFORMANCE

- A. Color CCTV/Sonar: All CCTV and/or Sonar work shall use color CCTV/sonar reproduction.
- B. CCTV Picture Quality:
  1. An approved test device shall be provided and be available on site throughout the Contract, enabling the tests specified in this clause to be checked.
  2. The test card shall be Marconi Regulation Chart No. 1 or its approved derivatives with a color bar, clearly differentiating between colors, with no tinting, to show the following: White, Yellow, Cyan, Green, Magenta, Red, Blue, and Black.
  3. At the start of each and every working shift, the camera shall be positioned centrally and at right angles to the test card at a distance where the full test card just fills the monitor screen. The Contractor shall ensure that the edges of the test card castellations coincide with the edges of the horizontal and vertical scan (raster). The card shall be illuminated evenly and uniformly without any reflection. The illumination shall be to the same color temperature as the color temperature of the lighting that recorded for subsequent use by the designated Engineer, the recording time to be at least 30 seconds. The type of camera used is to be identified on the test recording. The recording must show the camera being introduced into the test device and reaching its stop position. Other test devices may be used subject to approval by the designated Engineer. Test recordings shall also include the time and date of the recording. Test recordings shall be delivered to the Engineer on a weekly basis. The test recordings may be delivered on VHS tape or CD-ROM.
  4. The electronic systems, television camera and monitor shall be of such quality as to enable the following to be achieved:
- C. Shades of Gray: The gray scale shall show equal changes in brightness ranging from black to white with a minimum of five clearly recognizable stages.

- D. Color: With the monitor adjusted for correct saturation, the six colors plus black and white shall be clearly resolved with the primary and complementary colors in order of decreasing luminance. The gray scale shall appear in contrasting shades of gray with no tint.
- E. Linearity: The background grid shall show squares of equal size, without convergence/divergence over the whole of picture. The center circle shall appear round and have the correct height/width relationship ( $\pm 5\%$ ).
- F. Resolution: The live picture must be clearly visible with no interference and capable of registering a minimum number of TV lines/pictures height lines. The resolution shall be checked with the monitor color turned down. In the case of tube cameras this shall be 600 lines.
- G. Color Constancy: To ensure the camera shall provide similar results when used with its own illumination source, the lighting shall be fixed in intensity prior to commencing the survey. In order to ensure color constancy, generally no variation in illumination shall take place during the survey.
  - 1. The Contractor shall note that the designated Engineer may periodically check both the live and picture color consistency against the color bar. Any differences will require re-survey of the new length or lengths affected, at the Contractor's expense.
- H. Playback and CD-ROM Labeling:
  - 1. Playback video shall be capable of a resolution of a minimum of 400 lines recorded at standard (SP setting) VHS speed. CD-ROM playback imaging shall be linked to electronic out put of alpha-numeric data so that if necessary direct interrogation of database can take place with simultaneous viewing of CCTV/sonar images.
  - 2. Each CD-ROM disc shall be labeled by reference to the header record for the survey section completed together with the following information:
    - a. Client Name: "City of Atlanta"
    - b. Project Name
    - c. Contractor's Name
    - d. Contractor's logo is optional
    - e. Survey date(s)
    - f. Survey Method: "CCTV – Internal Sewer Condition Assessment"
    - g. CD Volume Label – "XXXXXXYYZZTT", where:

- i. XXXXXX is the Sewershed abbreviation, as provided by the City
    - ii. YY is the Company abbreviation, as provided by the City
    - iii. ZZ is the unique crew leader initials
    - iv. TT is a sequence number maintained for the crew leader
  - h. Video Filename(s): Alphanumeric using any convention. Filename is to be included in the header field as specified. Filename is limited to 5 characters (e.g. “00001” to “00004”)
- I. CCTV Focus/Iris/Illumination: The adjustment of focus and iris shall allow optimum picture quality to be achieved and shall be remotely operated. The adjustment of focus and iris shall provide a minimum focal range from 6 inches in front of the camera's lens to infinity. The distance along the sewer in focus from the initial point of observation shall be a minimum of twice the vertical height of the sewer. The illumination must allow an even distribution of the light around the sewer perimeter without the loss of contrast picture, flare out or shadowing.
- J. Sonar Survey Requirements:
- 1. Rates shall allow for:
    - a. Complete structural and service assessment to the equivalent standard as that obtained through conventional CCTV imagery
    - b. The means of attenuating flow, where necessary, to facilitate appraisal of the full sewer cross section
    - c. Measurement of flow depth and silt depth.
  - 2. Rates shall allow for continuous output on conventional annotated CD-ROM format of all sewers surveyed, supported by complete defect code sheets. Additionally, silt levels shall be assessed as a percentage depth of sewers at 25 foot intervals for each pipeline surveyed. To facilitate this requirement, and in addition, to assist in diametrical measurement particularly where a sewer is deformed and/or where a sewer has suffered hydrogen sulfide corrosion; screen graphic facilities shall be made available to enable measurements to be taken in any position across the diametrical profile of the sewer as the sonar survey proceeds and where specifically directed by the designated Engineer.
  - 3. Where combined CCTV and Sonar imagery is required the output shall display combined CCTV and Sonar images of the sewer being

surveyed. The sonar image shall be superimposed on the real CCTV image as a combined operation.

4. Rates shall allow for a comprehensive final report on the findings concerning major defects, including fractures, displaced joints, deformation, corrosion and lateral intrusions, as well as dominant surface features, including encrustation and silt depths.
5. The monitor display resolution shall be a minimum of 512 x 512 pixels. The color palette shall have a minimum of 16 colors with text.
6. The picture update speed shall not compromise compliance with Sub-clause A (1) or result in unsatisfactory picture resolution.
7. The range of resolution shall be  $\pm 1/10$  inch.
8. The maximum beam width of sonar energy pulse shall be no greater than 2 degrees from the center of the transducer.
9. The transducer shall be of the continuous scanning type.

K. Contractor's Data Quality Control Procedure:

1. The Contractor shall operate a quality control system, to be approved by the designated Engineer, which will effectively gauge the accuracy of all survey reports produced by the operator.
2. The system shall be such that the accuracy of reporting is a function particularly of:
  - a. The number of faults not recorded (omissions).
  - b. The correctness of the coding and classification of each fault recorded.
3. The minimum levels of accuracy to be attained under the various survey headings are as follows:
  - a. Header Accuracy 95%
  - b. Detail Accuracy 85%

- L. The Contractor's data quality control program shall include routine outside auditing of the work completed by a qualified subcontractor. The qualified subcontractor shall meet the minimum specified Contract requirements for the performance of the work and shall be approved in writing by the Engineer. The accuracy of the Contractor's data shall be based on the percentage of the data confirmed correct by the subcontractor. The minimum acceptable accuracy of the data shall be 85%. The general sequence of the auditing shall be as follows:

1. The Engineer shall randomly select one day per month, typically in the first week of the month, and the work performed during this day shall be reviewed and/or repeated by the qualified subcontractor.
2. If the work is greater than or equal to 85% accurate, no further outside auditing will be required for the month unless requested by the Engineer at his sole discretion. The cost for this audit is included in the allowances specified in the Bid Form.
3. If the work is less than 85% accurate, the Contractor shall at his own expense repeat and/or correct the work and have the work re-audited by the qualified subcontractor.
4. If this work is still less than 85% accurate, the Contractor shall repeat and/or correct and have the work re-audited, at his own expense, until the work is greater than or equal to 85% accurate.
5. When this re-audited work is found to be greater than or equal to 85% accurate, the Contractor shall have the work of another randomly selected day in the same month reviewed and/or repeated by the qualified subcontractor at the Contractor's own expense.
6. Steps 2 through 5 shall be repeated at the Contractor's own expense until the selected day is 85% accurate on the initial audit.
7. The occurrence of five randomly selected days not achieving 85% accuracy on initial subcontractor review will constitute cause for dismissal.
8. If the Contractor successfully meets the 85% accuracy requirement for the initial randomly selected day for two consecutive months (Step 2 above), the Contractor may subsequently audit one day every other month. The Contractor may continue auditing one day every other month until the initial randomly selected day does not meet 85% accuracy, at which time it must resume auditing one day every month.

### **3.07 COLLAPSED SEWERS/DEFECTIVE MANHOLES**

- A. Any sewer found with greater than 10% deformation (i.e. collapsed or near to collapse) must be reported to the designated Engineer immediately for remedial action. In the event of emergency phone (404)-624-0751.

- B. Any manhole found broken, cracked, with missing covers or surcharged, must be reported to the designated Engineer immediately for remedial action. In the event of emergency phone (404)-624-0751.
- C. Any sewer found where the existing conditions pose a threat of personal injury to the public, such as a collapsed sewer with attendant depression to roadway, must be protected by the Contractor until the Engineer arrives at the job site. In the event of emergency phone (404)-624-0751.
- D. Any manhole found where the existing conditions pose a threat of personal injury to the public, such as broken, cracked or missing covers or covers found in traveled portions of any sidewalk or roadway must be protected by the Contractor until the Engineer arrives at the job site. In the event of emergency phone (404)-624-0751.

### **3.08 TRAFFIC CONTROL**

- A. Refer to Specification Section 01500: Temporary Control of Construction Operations for requirements.

# **ATTACHMENT A**

## **DEFINITIONS**

[This page intentionally left blank]



## DEFINITIONS

---

### Notes:

- Features that are visible in the sewer during surveys/inspections and other key items are defined below.
  - Sewer defects are categorized under the following headings: Structural, Service, Protective Lining, and Constructional.
  - Normal parts of speech abbreviations apply (e.g., (n) for noun, (v) for verb, etc.)
- 

### Sewer Defects - Structural

**Angular Joints:** Adjacent conduit sections are angularly displaced at the joint.

**Break:** Pieces of the sewer conduit are noticeably displaced, differentially, and some pieces could be missing. A broken sewer is the most structurally serious defect. A hole in the fabric of the sewer is also classified as broken. A chipped sewer wall is not coded as broken, but should be entered into the “general comments” section of the coding sheet as such.

**Crack:** Crack line visible on the sewer wall, with the pieces of the wall still in place. The crack may be either longitudinal (i.e., following the longitudinal axis of the sewer), circumferential (i.e., around the periphery of the sewer), or spiral (i.e. helically around the sewer). Cracks are not themselves serious defects, but are indicative of the initial stages of sewer deterioration. Multiple cracks are a combination of both longitudinal and circumferential cracks.

**Collapse:** Structural integrity of the sewer conduit has been completely lost and deformation is greater than 10 percent. Percentage loss of cross-section is estimated to the nearest 5 percent.

**Corrosion:** The destruction of a cementitious or metal wastewater component and its material properties, because of a reaction with its surroundings (the sewage environment). Corrosion is usually a defect observable specifically in the soffit, and generally above the springings of the sewer conduit and in the proximity of force main discharges. Four levels of corrosion are identifiable:

- *Light Corrosion* is characterized by a slightly depressed pH (<6.0), and a concrete surface that can be penetrated with a sharp instrument under moderate hand pressure with the removal of some concrete material. The original concrete surface is fully recognizable and aggregate may or may not be exposed.

- *Moderate Corrosion* is characterized by some concrete loss with aggregate slightly exposed, but the original concrete surface is still distinguishable. The surface may have a thin covering of pasty material that is easily penetrated. There is generally a depressed wall pH (<5.0).
- *Severe Corrosion* is characterized by significant measurable concrete loss or active corrosion. Aggregate and, occasionally, reinforcing steel is exposed. The original concrete surface is not distinguishable. The surface is covered with soft, pasty corrosion products where active scouring is not present. There is generally a depressed wall pH (<0.3) indicating active corrosion.
- *Extreme Corrosion* is characterized by corrosion so extensive that the wall of the sewer has been completely corroded and earth can be observed behind the sewer wall.

Normal pH ranges (around 6.0) are applicable. A normal concrete surface is defined as that which cannot be penetrated or removed by a sharp instrument under moderate hand pressure. The surface of the concrete may have biological growth (slime build) and moisture but the concrete is normal and aggregate is not exposed.

**Deformation:** A measure of the vertical and horizontal reduction or change in cross-section of a sewer as a result of self-weight or external forces. Three levels of deformation are normally reported. These are:

- 0-5 percent deformation is acceptable, may not need structural upgrading, and normally may require periodic monitoring.
- 5-10 percent deformation requires some form of structural enhancement, possibly a lining;
- >10 percent deformation is a collapse condition and the sewer needs replacing.

Brick sewers may have some irregular or misshapen cross-sections built into the original sewer. Plastic pipes can deform without structural defects. Normally a built-in deformation of 6 percent is allowable in plastic sewers.

For inspection purposes, deformation is normally recorded to the nearest 5 percent.

**Fracture:** Wall of sewer visibly separated along the length and/or circumference of the sewer with the pieces of the sewer wall in place. The fracture may be either longitudinal (i.e., following the longitudinal axis of the sewer), circumferential (i.e., around the periphery of the sewer, or spiral (i.e. helically around the sewer). The sewer may be seen to suffer from some distortion. The defect is indicative of the secondary stage of sewer deterioration and constitutes a more serious problem than a crack. Multiple fractures are a combination of both longitudinal and circumferential fractures.

**Offset (Displaced) Joint:** Adjacent conduit sections are not concentric at the joint. Displacements are recorded as a fraction of the wall thickness of the conduit (t) as follows:

- *slight* -  $< t$
- *medium* -  $1 < t < 1.5$
- *large* -  $> 1.5 t$

**Separated (Open) Joint:** Adjacent conduit sections are open at the joint. Displacements are recorded as a fraction of the wall thickness of the conduit (t) as follows:

- *slight* -  $< t$
- *medium* -  $1 < t, 1.5$
- *large* -  $1.5 t$

**Surface Damage:** Surface of sewer conduit is damaged by spalling, wear, erosion, or any other deleterious mechanism other than corrosion (see **Corrosion**).

### **Sewer Defects - Service**

**Debris:** Obstructions in a sewer line, excluding items mechanically attached to the line such as protruding service connections, protruding pipe and joint materials. Percentage loss is normally given to the nearest 5 percent. (See also Silt)

- Debris is normally identified by the following characteristics:
- *Debris.* Pebbles, pieces of concrete, wood chippings, sticks, brick, and other extraneous material that could cause turbulence and/or reduction in hydraulic capacity
- *Ragging.* Paper and sanitary products

**Encrustation:** Mineral deposits left on the wall or joint of a sewer by the effect of infiltrating groundwater containing dissolved salts. Normally described as being light, medium, or heavy, and characterized by loss of percentage cross-sectional area, thus:

- light -  $< 5$  percent
- medium -  $> 5$  loss  $< 20$  percent
- heavy  $> 20$  percent loss

**Ground Water Infiltration:** Water entering sewers and manholes via defective joints and connections, broken pipes, fractured manholes, etc., due to the effects of a high ground water table. Various levels of ground water infiltration are identified, namely as follows:

- Weeper - The slow ingress of infiltration through sewer/manhole joints or structural defects, identified by glistening effect of the water under the influence of survey lighting apparatus
- Dripper - Infiltration characteristically dripping into the wastewater system through sewer/ manhole joints or structural defects
- Runner - Infiltration running into the wastewater system through sewer/manhole joints or structural defects
- Gusher - Infiltration rapidly entering the wastewater system under hydrostatic pressure through sewer/manhole joints or structural defects

**Line Deviation:** Vertical or horizontal divergence of alignment of sewer conduit line encountered during inspection, also known as "change in direction" or "change in alignment."

**Obstruction:**An obstruction in the sewer conduit resulting in stoppage of the inspection or survey. Obstructions can be:

- *General*, e.g., shopping cart, ball, or rock
- *Mechanical*, e.g., water main installed through sewer
- *Structural*, e.g., support mechanism such as a pile or tie back anchor
- *Strata*, e.g., rock or stone which has become dislodged and fallen onto the invert

**Roots:** Intrusion of roots through defects in sewer conduits, laterals, or manholes. Described as fine, medium, or tap roots, depending on severity as follows:

- *Fine roots:* slender or thin fibrous roots that partially result in a reduction in flow capacity
- *Medium roots:* mass of fine roots less than 50% of the area of the pipe
- *Tap roots:* individual root strands more than 1/2 inch thick.
- *Ball roots:* mass of roots more than 50% of the area of the pipe

**Silt:** Any and all solid or semi-solid materials, including fine and granular material such as sand, grit, gravel and rock, as well as grease, sludge, slime, debris or any other loose material or encrustation lodged in the manhole or sewer.

**Water Level:** The depth of water at the observed point in the sewer conduit, in percentage to nearest 5 percent.

## **Sewer Defects - Protective Lining**

**Blister:** A concentrated swelling of the *protective coating* over the host conduit.

**Bulge:** A concentrated swelling of the *protective liner* over the host conduit.

**Degradation:** Break down by biological action of the protective liner, protective coating, or host conduit.

**Delamination:** Separation of internal layers of the protective lining material. Loss of internal bonding, chemical or mechanical.

**Detached:** Extensive separation of the protective lining material or protective coating from the host conduit.

**Missing:** Where the sewer conduit has no protective coating or protective lining through the sewer conduit as indicated on as-built drawings, or on job files.

**Tear:** When the protective lining has become torn.

**Weld Failure:** The opening up of the weld between adjacent pieces of protective lining due to physical or chemical breakdown.

**Wrinkle:** The incorporation of a longitudinal or circumferential fold, typically in a CIPP lining due to stretching or excessive material. Normally the wrinkle should not exceed more than 1 percent of diameter for protective linings equal to or greater than 24 inches, and more than 2 percent of diameter for protective linings in sewers less than 24 inches. (Establish using 3-dimensional templates or similar.)

## **Sewers - Construction**

**Battens:** Anchoring strips used to attach PE, PVC, or HDPE liners to the host sewer conduit (the sewer being treated) or annulus grout. Battens are normally made of plastic or stainless steel.

**Buried Manhole:** A manhole on a sewer, which is not visible at ground surface. A buried manhole may or may not be designated for assessment.

**Chimney:** The cylindrical, variable height access portion of the manhole structure. The chimney extends from the top of the corbel above the manhole chamber to the base of the manhole frame, and is used for adjusting the finished level of the manhole frame.

**Coal Tar Epoxy:** A chemically cured, two component coal tar coating which has been in use since the 1950's. In order to be successful as a coating, the surface preparation has to be of a very high order that is difficult, if not impossible, to achieve in the context of sewer conduits.

**Connection:** A sewer tap including break-in/hammer tap or saddle connection, of lateral sewer to another sewer.

**Construction Exit:** A stone-stabilized pad located at any point where traffic will be leaving a construction site to a public right-of-way, street, alley, sidewalk, or parking area.

**Corbel or Cone:** That portion of a manhole structure that slopes upward and inward from the barrel of the manhole to the frame diameter or required chimney (access shaft). Corbel refers to the oversailing brickwork that supports the cover and frame. Cone refers to a precast section.

**Critical Path Method (CPM):** A planning and scheduling technique involving the charting of all events and operations to be encountered in completing a given process, rendered in a form permitting determination of the relative significance of each event and establishing the optimum sequence and duration of operations.

**Crown:** The external elevation at the top of the sewer conduit (see also **Invert, Soffit**).

**Cured-in-Place (CIPP):** A pipe rehabilitation system in which the flexible lining (either epoxy resin or polyester resin) impregnated felt is water or air inverted or winched and inverted into an existing sewer and subsequently heat cured. The reformed pipe fits snugly into, and follows closely, the contours of the existing (host) pipe. The work also involves the reconnection of the existing sewer service property connections and television inspection of the lined pipeline.

**Designated Manhole (s):** Manholes identified by Engineer to be assessed.

**Drop Pipe:** The pipe that vertically connects the upstream sewer conduit to the invert of the through flow channel in a manhole. The drop pipe is strapped to the inside of the manhole, or surrounded in concrete if immediately outside the manhole.

**Float:** Float or slack time associated with one chain of activities is defined as the amount of time between earliest start date and latest start date or between earliest finish date and latest finish date for such activities, as calculated as part of the accepted Schedule Submittal.

**Flow bypass:** The transfer of flow from an upstream section or segment of sewer to the same sewer downstream (generally downstream of the section being rehabilitated) via temporary piping. Generally flow bypass and diversion pumping may be described as the efficient and effective installation and operation of bulkheads, plugs, hoses, piping, and pumps to maintain sewage flow and prevent backup, spillage, flooding or overflow.

**Flow diversion:** The transfer of sewage from an upstream section or segment of the originating sewer to another sewer. The flow is generally not returned to the originating sewer but may in some cases be transferred to another service area. Generally flow bypass and diversion pumping may be described as the efficient and effective installation and operation of bulkheads, plugs, hoses, piping, and pumps to maintain sewage flow and prevent backup, spillage, flooding or overflow.

**Fold and Form Pipe:** A pipe rehabilitation system in which the plastic pipe (either PVC or HDPE) is manufactured in folded shape of reduced cross-sectional area and is pulled into an existing sewer and subsequently expanded with pressure and heat. The reformed pipe fits snugly into and follows closely the contours of the existing (host) pipe.

**HDPE Liner:** The high density polyethylene (HDPE) pipe or sheeting that is used to renovate sewer conduits subject to structural and corrosive defects.

**Hobas Pipe:** Proprietary Glass Fiber Pipe used for sewer conduit renovation purposes.

**Invert:** The internal elevation at the bottom of the sewer (see also **Soffit, Crown**).

**Joints:** The means of connecting sectional lengths of sewer pipe into a continuous (flexible jointed or articulated) sewer line using various types of jointing materials. The number of joints depends on the lengths of the pipe sections used in the specific sewer construction work. See pipe manufactures catalogue.

**Junction:** A factory-made tap.

**Junction Box:** A subsurface structure normally constructed in reinforced concrete in which two or more sewer conduits meet.

**Lateral:** Building or house service connection to sewer or sewer to sewer connection.

**Lining:** (n) Also termed "insitu lining," is an internal lining material applied to the wall of an existing sewer for structural and/or protective reasons. (v) Active renovation (i.e., by insertion) of a prefabricated lining into an existing sewer.

**Manhole:** A subsurface structure in which two or more pipes meet, with person access from the ground surface.

**Manhole Structure:** Reference to and all activities relevant to manhole structures throughout the text shall also be taken to include junction boxes, inspection chambers, drop shafts, sumps, and all other auxiliary structures appurtenant to the sewerage system.

**Mapped Manhole:** A manhole that appears on the City's sewer system map. A mapped manhole may or may not be designated for assessment.

**Cured-In-Place Pipe (CIPP):** A system by which a burster unit splits the existing pipe while simultaneously installing a new polyethylene pipe. The new pipe may be of the same size or larger size. The work also involves the reconnection of the existing sewer service property connections and television inspection of the polyethylene pipe.

**Raised manhole:** *A manhole in which the cover and frame are above normal levels above ground, i.e., more than 30-inches above ground level. A raised manhole may or may not be designated for assessment.*

**Schedule of Record:** The Schedule of Record will be the Official Project Schedule for this Contract. All updates and/or revisions relating to coordinating the Work, scheduling the Work, monitoring the Work, reviewing the progress payment requests, evaluating time extension requests, and all other objectives shall be made to this Schedule. No other schedule will be recognized for this Contract.

**Sewer Inspection:** Viewing the sewer pre- or post preconditioning and/or pre-or post rehabilitation with the aid of CCTV and/or sonar equipment, and/or manually, to assess overall condition. No data logging is required.

**Sewer Survey:** Viewing the sewer with the aid of CCTV and/or sonar equipment, and/or manually, to assess internal structural and/or service condition as well as assess the structural and/or service condition of laterals. Data logging is required.

**Soffit:** The internal elevation at the top of the sewer (see also **Crown, Invert**).

**Stream crossing:** A temporary structure installed across a perennial or nonperennial stream or watercourse for use by construction equipment. Stream crossing shall be in accordance to detail in the Contract Drawings and the Georgia Erosion and Sedimentation Act of 1975 and its amendments.

**Tap (Connection):** Factory tap, break-in/hammer tap or saddle connection of lateral sewer to another sewer.

**Through Flow Channel:** The channel that passes sewage directly through the (concrete) manhole base from the upstream sewer to the downstream sewer, also called the manhole invert.

**T-Lock:** HDPE sheeting used specifically for protecting sewer conduits against corrosion.

**Unburied Manhole:** *A manhole on a sewer to be assessed formerly buried below ground surface. An unburied manhole may or may not be designated for assessment*

**Unmapped Manhole:** A manhole not included on the City's sewer system map. An unmapped manhole is also known as an uncharted manhole.

**Wet Well:** The wet side or inlet side of a wastewater pumping station.



## **Sewers - General**

**Abrasion:** Hydraulic wear or scour on the wall of a sewer, through-flow channel or manhole wall.

**Above Ground Sewer (Aerial Sewer):** An unburied sewer (generally a sanitary sewer), supported on piers, pedestals or bents to provide a suitable grade line.

**Aggressive:** A property of the sewage conveyed that results in accelerated corrosion of the conveying sewer conduit.

**Building Sewer:** The conduit that connects building wastewater sources to the public or street sewer, including lines serving homes, public buildings, commercial establishments and industry structures. Referred to also as house sewer, building connection, service connection or lateral connection.

**Cleaning:** Techniques used to clean sewer lines either hydraulically or mechanically. *Hydraulic cleaning* involves using water, such as water pumped at a high velocity spray and water flowing by gravity or head pressure. Devices include high-velocity jet cleaners, cleaning balls (or pigs) and hinged-disc cleaners. *Mechanical cleaning* includes methods utilizing rodding machines, bucket machines, kites, winch-pulled brushes and wheelbarrows with spades.

**Collector Sewer:** A sewer located in the public way that collects wastewater discharges through building sewers, and conducts such flows to larger interceptor sewers, lift stations and treatment works.

**Combined Sewer:** A sewer that is designed to serve as both a sanitary sewer and a storm sewer.

**Conduit:** A pipe or other opening, buried or above ground, for conveying hydraulic traffic, pipelines, cables or other utilities.

**Core Area:** That essential part of a sewer network containing critical sewers and other sewers where hydraulic problems are likely to be most severe, and that require detailed definition within a flow simulation model.

**Corrosion Rate:** The rate (usually an average) at which corrosion of a component of the wastewater network progresses; expressed as though it were linear in units of mdd (millimeters per square decimeter day) for weight change, or mpy (millimeters per year) for thickness changes.

**Corrosion Resistance:** Ability of a material to withstand corrosion within the wastewater network.

**Creep**: The dimensional change, with time, of a sewer renovation material (lining) under continuously applied stress after the initial elastic deformation.

**Critical Sewers**: The major sewers in a wastewater network that would exhibit the most significant consequences in the event of structural collapse.

**Critical Soils**: Appraisal of the nature of soils surrounding sewers. Soils of *High-Criticality* are composed of silts and sands. Those of *Medium-Criticality* consist of low plasticity clays and gravel. Soils of *Low-Criticality* consist of medium to high plasticity clays and all clays where the sewer was constructed in tunnel.

**Deflection**: Reduction in vertical diameter and/or distortion in shape of a conduit as a result of self-weight or external forces.

**Degradation**: Breakdown in chemical resilience of a plastic product.

**Effluent**: Outflow or discharge from a sewer or wastewater treatment product.

**Elastic Modulus**: Characteristic of the stress build-up associated with a given strain in a conduit or lining (see also **Flexural Modulus**). Typically a feature of the strength characteristics of lining materials in sewers.

**Elongation**: The increase in length of a material stressed in tension.

**Embrittlement**: Loss of ductility of a material, resulting from a chemical or physical change.

**Environmental Stress Cracking**: The visible manifestation of a material's susceptibility to crack under the influence of specific chemical or mechanical stresses.

**Epoxy**: Resin formed by the reaction of bisphenol and epichlorohydrin.

**Erosion**: Deterioration of the surface of a component of the wastewater system resulting from the action of harder material suspended in sewage on the wastewater component.

**Exfiltration**: The leakage or egress of sewage from the wastewater system into the surrounding area, usually the ground, through leaks in pipes, joints, manholes, or other sewer system structures and components; the reverse of infiltration.

**External Structural Condition**: Appraisal of a length of sewer between manholes in to identified external forces (e.g., from traffic load if less than 4 feet below highway; ground water pressure if below the water table, etc.) and nature of ground (e.g., soil criticality, chemical inertness, etc.).

**Flexural Modulus**: The slope of the elastic strain curve defined by flexural load versus resultant strain. A high flexural modulus indicates a stiffer material.

**Flexural Strength:** The strength of a material in bending expressed as the tensile stress of the outermost fibers at the instant of failure.

**Flow Attenuation:** The process of reducing the peak flow rate in a sewer system by redistributing the same volume of flow over a longer period.

**General Corrosion:** Uniform corrosion, usually a phenomenon observed above the flow line in the sewer.

**Ground Water Table (Level):** Upper surface of the zone of saturation in permeable strata. Of special relevance to sewer survey or inspection if immediately above or below the sewer. The sewer is more susceptible to ground water infiltration if above the sewer. (See also **Ground Water Infiltration**).

**Grout:** (1) A fluid mixture typically consisting of cement, water and sand that can be poured or pumped easily. (2) Chemical mixtures that have the capability of stopping water infiltration through small holes and cracks in sewers and manholes.

**Grouting:** (1) The joining together of loose particles of soil in such manner that the soil so joined becomes a solid mass impervious to water. (2) The process of introducing (typically by pumping) a cement and water grout into the annular space between a host pipe and a slipline pipe.

**Header:** All reference data at the head of the coding sheet, other than sewer condition data, attaching to the sewer being inspected.

**Hydraulic Gradient:** An imaginary line through the points to which water would arise in a series of vertical tubes connected to the sewer.

**Hydrogen Sulfide Corrosion:** Hydrogen sulfide corrosion is the attack of cementitious materials caused by the microbiological conversion of sulfates within sewage to gaseous sulfides and then to sulfuric acid. The corrosion causes a reduction in the sewer wall thickness and a loss of structural integrity.

**Infiltration:** See **Ground Water Infiltration**.

**Infiltration/Inflow (I/I):** Pertaining to the study and understanding of the undesirable ingress of infiltration and inflow into the wastewater system.

**Inflow:** The rain-induced water entering the sewerage or wastewater system from areas not intended to drain to the sewerage or wastewater system. Inflow is thus distinguished from infiltration. (See also **Ground Water Infiltration**).

**Interceptor Sewer:** A sewer that receives flow from collector sewers and conveys the wastewater to treatment facilities.

**Internal Condition Grade (ICG):** The relative state of the internal service or structural performance of the sewer in relation to specified criteria. In broad structural terms, it is a measure of the sewer's probability to collapse.

**Internal Sewer Service Condition:** The ability of a length of sewer between manholes to perform its intended function of conveying sewage, determined by the degree of non-structural defects within the sewer.

**Man Entry Sewers:** Those sewers considered to be large enough for safe manual (physical) inspection, survey and work activities (e.g., manual renovation and repair). Generally considered to be greater than 1,000 millimeters (around 40 inches) in size. Safety considerations are important before contemplating and undertaking such a survey.

**Manholes Length, Section or Segment:** The length of sewer between two adjacent manholes.

**Non-Man Entry Sewers:** Those sewers considered to be too small for manual inspection, survey and work activities (e.g., renovation and repair). Generally considered to be less than 1,000 millimeters (around 40 inches) in size. Normally, these sewers are inspected and surveyed using CCTV, and repairs are carried out robotically.

**Non-uniform Corrosion:** Corrosion that attacks small, localized areas of the sewer, usually resulting in material loss. Characteristic of poorly made non-uniform concrete.

**Overflow:** (a) The excess water that flows over the ordinary limits of the sewer, manhole, or containment structure. (v) An outlet, pipe, or receptacle for excess water.

**Oxidation:** Loss of electrons, as when metal goes from the metallic state to the corroded state.

**pH:** A measure of the acidity or alkalinity of sewage, expressed as the logarithm, base 10, of the inverse of the hydrogen ion concentration (the weight of the hydrogen ions multiplied by the activity coefficient, which is close to unity in most fresh waters and in other waters of relatively low ionic strength). Most aqueous solutions have pH values in the range 0-14, with pure water (which is neutral) having a pH value of 7. Values above or below 7 indicate alkalinity or acidity, respectively.

**Pipeline:** An alternative definition of a length of sewer that exists as a single branch within the wastewater network. It consists of many pipes and extends from manhole to manhole.

**Pipe Sealing:** Sealing of existing circumferential pipe crack or pipe joint using grouting materials under air pressure.

**Pipe Repair:** Repair of fracture, break or longitudinal crack or fracture in a pipeline by manual (in Man entry sewers) or robotic (in Non-man entry sewers) structural repair techniques.

**Pitting**: Localized corrosion resulting in deeper penetration of the concrete surface in only a few spots.

**Pitting Factor**: Depth of the deepest pit divided by the average penetration calculated from weight loss.

**Sanitary Sewer**: A sewer intended to carry only sanitary or sanitary and industrial wastewater from residences, commercial buildings, industrial parks, and institutions.

**Scaling**: Thin layer of deposit or remnant of sewer material observed during the course of inspection/ survey.

**Serviceability of the Sewer or Sewer System**: Continued service life with high degree of confidence that failure will not occur during its long-term service.

**Sewer**: An underground conduit designed to carry wastewater. A sewer can take the form of a pipe or tunnel and can be of many shapes (e.g., circular, ovoid, u-shaped, rectangular, oval, etc.) and materials (e.g., concrete, asbestos cement, truss, clayware, brick, steel, cast iron, etc.). Sewers convey either storm water or wastewater.

**Sewer Infiltration**: See **Infiltration**.

**Sewer Inflow**: See **Inflow**.

**Sewer Inspection**: Viewing the sewer primarily with the aid of sewer CCTV equipment, and or manually, to assess overall condition. No data logging is required. Inspection is normally carried out as an adjunct to other activities in the sewer such as preparatory cleaning or pre/post renovation measures. (See also **Sewer Survey**).

**Sewer Structural Condition**: Assessment of the structural integrity of the sewer.

**Sewer Service Condition**: Assessment of the service condition of the sewer, reflecting the sewer conduit's capacity, potential for blockage, and water tightness.

**Sewer Springings**: The imaginary points on the wall of the sewer at the ends of the horizontal diameter. Normally considered to be the position where the arch, or top half, of the sewer commences.

**Sewer Survey**: Viewing and appraising the sewer with the aid of:

Internally:

- *Sewer CCTV equipment*, and/or manually to assess internal structural and/or service condition of the sewer (as well as assess the structural and/or service condition and location of laterals). Data logging is required and the depth of flow is not more than 25 percent of the vertical dimension of the sewer;

- *Sewer profiling equipment*, to establish the dimensional configuration of the sewer (including percentage deformation). Flow is normally bypassed;
- *Sonar equipment*, when the sewer is flooded or partially flooded to assess internal structural and/or service condition of the sewer (as well as assess the structural and/or service condition and location of laterals). Data logging is required, though not with the same resolution as with CCTV;
- *A combination of sonar and CCTV equipment*, when the depth of flow is between 25 percent and 75 percent in sewers larger than 18 inches; and/or
- *Thermographic sensor-equipment*, to determine the position of laterals in lined sewers.

Externally:

- Ground probing radar antennae, to assess external conditions (e.g., voids) immediately relating to the sewer;
- Seismic resonance testing equipment, to assess stratification and nature of the ground between the ground surface and the sewer; and/or
- Such other equipment that provides insights into the nature of the sewer and its surrounding conditions.

A sewer survey normally forms the basis of an engineering interpretation of the internal condition of the sewer (see also **Sewer Inspection**).

**Springing**: See also **Sewer Springing**.

**Standard Dimension Ratio (SDR)**: Ratio of the pipe diameter to wall thickness.

**Surcharge**: Occurs and is witnessed when the sewer flow exceeds the hydraulic capacity of the sewer line.

**Uniform Corrosion**: Corrosion that results in an equal amount of material loss over an entire sewer surface

## **ATTACHMENT B**

# **INTERNAL SEWER CONDITION ASSESSMENT SAMPLE REPORTS**

**(For use with City of Atlanta Database)**

[This page intentionally left blank]



Date : 02 05 2000		Time : 10:28		SURVEY REPORT				Page Number : 167	
Contractor	Contract No	Job No	Drainage Area	Div	Dist	Pipe L. Ref			
ASI/DG	ASG/0001	0	0	0	000	23250201501X			
Location			Place Name						
BERKELE STREET			MCDANIEL BASIN						
Start Manhole No. :		23250201001		Depth :		08.0		Total Length : 365.0	
Finish Manhole No. :		23250201501		Depth :		09.0		Suyed Length : 280.7	
Use	Direction	Size	Shape	Material	Lining	Yr Laid	Pipe L		
COMBINED	UPSTREAM	8in	CIRC.	U. CLAY		2	3.00		
CD-ROM No	U. Model	Comments							
00016	-								
Purpose	Weather	Location	Further Information						
	DRY								

DETAIL				Page Number : 167	
Digit Ph.	Dist	CD Code	Other	Details	

0136	0.0	ST	Start of Survey	[0065]	
0280	0.0	MH	Manhole 23250201001		
0560	0.0	WL	Water Level is now 05%		
0163	30.2	JN	Junction. 6in at 03o/c	FW	
0180	41.6	JDM	Joint Displaced Medium		
0186	43.3	JN	Junction. 6in at 09o/c	SW	
0200	54.6	OJM	Open Joint Medium		
0203	56.3	JN	Junction. 6in at 09o/c	SW	
0226	79.0	JN	Junction. 6in at 03o/c	FW?	
0236	83.2	JN	Junction. 6in at 09o/c	FW	
0260	106.5	JN	Junction. 6in at 02o/c	FW?	
0270	108.5	JN	Junction. 6in at 09o/c	FW	
0286	120.9	CNI	Conn. Intruding by 1in. 6in Dia at 12o/c	FW	
0303	135.4	CL	Longitudinal Crack at 12o/c		
0310	136.0	CNI	Conn. Intruding by 1in. 6in Dia at 12o/c	FW?	
0326	147.2	JN	Junction. 6in at 03o/c	FW	
0333	149.8	JN	Junction. 6in at 09o/c	SW	
0346	157.5	JN	Junction. 6in at 03o/c	SW	
0366	175.9	JN	Junction. 6in at 10o/c	SW	
0376	181.0	JN	Junction. 6in at 02o/c	FW?	
0386	184.9	JN	Junction. 6in at 10o/c	SW	
0780	184.9	S1 DES	Debris Silt. 05% loss		
0416	209.3	JN	Junction. 6in at 10o/c	FW?	
0840	209.3	F1 DES	Debris Silt. 05% loss		
0433	218.9	JN	Junction. 6in at 02o/c	SW	
0453	234.2	JN	Junction. 6in at 10o/c	SW	
0470	244.8	FCJ	Circumferential Fracture at Joint at 03 to 05o/c		
0483	254.7	JN	Junction. 6in at 02o/c	FW?	
0970	254.7	S2 DES	Debris Silt. 05% loss		
1940	254.7	S3 RF	Fine Roots		
0490	257.5	JN	Junction. 6in at 09o/c	SW	
0513	279.5	C2 DES	Debris Silt. 50% loss		
0520	280.6	JN	Junction. 6in at 02o/c	SW	

DETAIL CONTINUED ON NEXT PAGE For Page Number : 167



Collier Rd. Outfall Sewer Improvements – Phases 1 & 2  
 Section 02752 – Internal Sewer Condition Assessment

SURVEY REPORT							Page Number : 170
Date : 02 05 2000				Time : 17:20			
Contractor	Contract No	Job No	Drainage Area	Div	Dist	Pipe L. Ref	
ASI/DG	ASG/0001	0	0	0	000	23250200401X	
Location			Place Name				
MCDANIEL STREET			MCDANIEL BASIN				
Start Manhole No. :	23250201901	Depth :	09.6	Total Length :	085.8		
Finish Manhole No. :	23250200401	Depth :	08.0	Suyed Length :	085.8		
Use	Direction	Size	Shape	Material	Lining Yr Laid	Pipe L	
COMBINED	UPSTREAM	12in	CIRC.	U. CLAY	2	3.00	
CD-ROM No	U. Model	Comments					
00016	-	-					
Purpose	Weather	Location	Further Information				
	DRY		-				

DETAIL				Page Number : 170
Digit Ph.	Dist	CD Code	Other Details	

0683	0.0	ST	Start of Survey	[0341]
1370	0.0	MH	Manhole 23250201901	
1940	0.0	WL	Water Level is now 05%	
0683	0.0	S1	DEG Debris Grease at 07o/c to 05o/c. 05% loss	
0693	13.9	JDM	Joint Displaced Medium	
0700	18.3	OB	Obstruction. 05% loss STONE	
0710	26.3	S2	DES Debris Silt. 05% loss	
0720	35.4	CXI	Conn Defect/Intr. by 3in. 6in Dia. At 10o/c SW	
1440	35.4	JN	Junction. 6in at 02o/c CAPPED OFF	
0736	40.5	JN	Junction. 6in at 02o/c CAPPED OFF	
0750	46.6	C2	DES Debris Silt. 15% loss	
0766	60.9	JN	Junction. 6in at 10o/c CAPPED OFF	
0783	73.7	JX	Junction. Defective. 6in Dia at 02o/c SW	
1570	73.7	B	Break. From 11o/c to 01o/c	
0796	81.1	JN	Junction. 6in at 10o/c	
0800	85.8	F1	DEG Debris Grease at 07o/c to 05o/c. 05% loss	
1600	85.8	F2	DES Debris Silt. 15% loss	
2400	85.8	MH	Manhole 23250200401	
0800	85.8	FH	Finish of Survey.	

SUMMARY				Page Number : 170
St Mh No. :	23250201901	Fh Mh No. :	23250200401	Suyed Length : 085.8
SOME MAJOR defects in this length :				Deformations : NO
Breaks/Holes		Mult/Long/Circ	Heavy/Medium	Gusher/Runner Mass
Fractures		Encrustation	Infiltration	Roots Obstructions
YES	NO	NO	NO	NO YES
Faulty Junctions/Connections :				YES
END OF SUMMARY				

< SURVEY REPORT >						Page Number : 184 >
Date : 02 07 2000			Time : 14:52			
Contractor	Contract No	Job No	Drainage Area	Div Dist	Pipe L. Ref	
ASI/DG	ASG/0001	0	0	0 000	23350305601X	
Location			Place Name			
GAULT STREET			BOULEVARD BASIN			
Start Manhole No.	: 23350305601	Depth :	22.0	Total Length :	501.2	
Finish Manhole No.	: 23350315501	Depth :	00.0	Suyed Length :	501.2	
Use	Direction	Size	Shape	Material	Lining Yr Laid	Pipe L
COMBINED	D/STREAM	12in	CIRC.	U. CLAY	2	3.00
CD-ROM No	U. Model	Comments				
00017	-	-				
Purpose	Weather	Location	Further Information			
DRY			-			

< DETAIL >				Page Number : 184 >
Digit Ph.	Dist	CD Code	Other Details	

0786	0.0	ST	Start of Survey	[0392]
1580	0.0	MH	Manhole 23350305601	
2360	0.0	WL	Water Level is now 05%	
0790	6.0	S1 EMJ	Encrust Med at Jnt. 15% loss at 07o/c to 05o/c CLOCKS VARY	
0800	12.9	EHJ	Encrust Heavy at Jnt. 25% loss at 12o/c to 05o/c	
0810	15.3	IDJ	Infiltration Dripping at Joint at 11o/c to 12o/c	
0816	18.6	EHJ	Encrust Heavy at Jnt. 25% loss at 01o/c to 05o/c	
0823	24.7	CL	Longitudinal Crack at 12o/c	
0830	31.5	FL	Longitudinal Fracture at 12o/c	
0840	43.2	EHJ	Encrust Heavy at Jnt. 30% loss at 07o/c to 05o/c	
0846	46.3	EHJ	Encrust Heavy at Jnt. 25% loss at 07o/c to 05o/c	
1700	46.3	S2 IDJ	Infiltration Dripping at Joint at 12o/c	
2600	46.3	RFJ	Fine Roots at Joint	
0856	50.9	EHJ	Encrust Heavy at Jnt. 50% loss at 09o/c to 03o/c OBSCURING VISION	
0920	87.5	F2 IDJ	Infiltration Dripping at Joint at 12o/c	
0956	147.1	IDJ	Infiltration Dripping at Joint at 12o/c	
0966	161.0	EHJ	Encrust Heavy at Jnt. 25% loss at 09o/c to 03o/c	
1940	161.0	IDJ	Infiltration Dripping at Joint at 11o/c	
3080	161.0	RFJ	Fine Roots at Joint	
0973	166.5	EHJ	Encrust Heavy at Jnt. 25% loss at 08o/c to 12o/c	
0983	171.1	IDJ	Infiltration Dripping at Joint at 11o/c	
0996	194.7	IDJ	Infiltration Dripping at Joint at 11o/c	
1003	202.4	IDJ	Infiltration Dripping at Joint at 01o/c	
1016	213.7	BJ	Break at Joint. From 06o/c to 08o/c	
1026	217.6	IDJ	Infiltration Dripping at Joint at 11o/c to 12o/c	
1033	225.2	IDJ	Infiltration Dripping at Joint at 01o/c	
1050	252.9	F1 EMJ	Encrust Med at Jnt. 15% loss at 07o/c to 05o/c CLOCKS VARY	
1300	252.9	S3 ELJ	Encrust Light at Joint at 07o/c to 05o/c CLOCKS VARY	
1066	286.4	IDJ	Infiltration Dripping at Joint at 12o/c	
1073	296.2	RMJ	Mass Roots at Joint. 30% loss	
1350	296.2	IDJ	Infiltration Dripping at Joint at 02o/c	

DETAIL CONTINUED ON NEXT PAGE For Page Number : 184

< CONTINUATION PAGE >			< Page Number : 184 >
Location GAULT STREET	Place Name BOULEVARD BASIN		
Start Manhole No. : 23350305601	Depth : 22.0	Total Length : 501.2	
Finish Manhole No. : 23350315501	Depth : 00.0	Suyed Length : 501.2	

< DETAIL CONTINUED >			< Page Number : 184 >
Digit Ph.	Dist	CD Code	Other Details

1086	304.2	RMJ	Mass Roots at Joint. 10% loss
1113	349.6	RMJ	Mass Roots at Joint. 65% loss
1130	367.7	RMJ	Mass Roots at Joint. 05% loss
1133	370.7	RMJ	Mass Roots at Joint. 60% loss
1146	375.8	RMJ	Mass Roots at Joint. 05% loss
1150	377.8	S4 RFJ	Fine Roots at Joint
1186	441.6	BJ	Break at Joint. From 09o/c to 12o/c
1193	442.7	B	Break. From 11o/c to 01o/c
1200	444.8	B	Break. From 11o/c to 01o/c REPAIRED
1206	446.3	CCJ	Circumferential Crack at Joint at 07o/c to 09o/c
1213	448.5	B	Break. From 10o/c to 01o/c REPAIRED
1220	451.8	B	Break. From 11o/c to 01o/c REPAIRED
1230	454.7	B	Break. From 10o/c to 12o/c REPAIRED
1240	457.2	B	Break. From 10o/c to 12o/c REPAIRED
1250	460.3	B	Break. From 09o/c to 01o/c REPAIRED
1256	462.1	B	Break. From 10o/c to 01o/c REPAIRED
1266	471.9	B	Break. From 11o/c to 02o/c REPAIRED
1273	478.5	RMJ	Mass Roots at Joint. 25% loss
1750	478.5	RTJ	Tap Roots at Joint
1346	485.1	RMJ	Mass Roots at Joint. 25% loss
1360	492.7	S5 DES	Debris Silt. 10% loss
1370	501.2	F3 ELJ	Encrust Light at Joint at 07o/c to 05o/c CLOCKS VARY
1940	501.2	F4 RFJ	Fine Roots at Joint
3080	501.2	F5 DES	Debris Silt. 10% loss
3760	501.2	MH	Manhole 23350315501
1370	501.2	FH	Finish of Survey.

< SUMMARY >			< Page Number : 184 >
St Mh No. : 23350305601	Fh Mh No. : 23350315501	Suyed Length : 501.2	
SOME MAJOR defects in this length : Deformations : NO			
Breaks/Holes	Mult/Long/Circ Fractures	Heavy/Medium Encrustation	Gusher/Runner Mass Infiltration
YES	LONG	HEAVY MEDIUM	NO MASS
Faulty Junctions/Connections : NO			
< END OF SUMMARY >			

[This page intentionally left blank]

## **ATTACHMENT C**

### **DEFECT, MATERIAL, SHAPE, AND LINING CODES**

[This page intentionally left blank]



**DEFECT CODES SORTED ALPHABETICALLY**

CONT. DEFECT	CODE	DEFINITION	DIAMETER	CLOCK AT	CLOCK TO	PERCENT / INTRUSION	REMARKS
Optional	<b>B</b>	Broken pipe	N/A	Req'd	Optional	N/A	Optional
N/A	<b>BR</b>	Branch major	Req'd	Optional	N/A	N/A	Optional
Optional	<b>CC</b>	Crack circumferential	N/A	Req'd	Req'd	N/A	Optional
Optional	<b>CL</b>	Crack longitudinal	N/A	Req'd	N/A	N/A	Optional
Optional	<b>CM</b>	Cracks multiple	N/A	Req'd	Req'd	N/A	Optional
N/A	<b>CN</b>	Connection	Req'd	Req'd	N/A	N/A	Enter Connection Material
N/A	<b>CNA</b>	Connection abandoned	Req'd	Req'd	N/A	N/A	Optional
N/A	<b>CNI</b>	Connection, intruding	Req'd	Req'd	N/A	Intr inches	- Enter Connection Material
N/A	<b>CXA</b>	Connection, defective abandoned	Req'd	Req'd	N/A	Intr inches	- Enter Connection Material
Optional	<b>CU</b>	Camera underwater	N/A	N/A	N/A	%	Optional
N/A	<b>CX</b>	Connection defective	Req'd	Req'd	N/A	N/A	Enter Connection Material
N/A	<b>CXI</b>	Connection defective, intruding	Req'd	Req'd	N/A	Intr inches	- Enter Connection Material
Optional	<b>D</b>	Deformed sewer	N/A	N/A	N/A	%	Optional
Optional	<b>DB</b>	Displaced bricks	N/A	Req'd	Optional	N/A	Optional
N/A	<b>DC</b>	Dimension of sewer changes	Req'd	N/A	N/A	N/A	Optional
Optional	<b>DE(J)</b>	Debris (non-silt/grease)	N/A	N/A	N/A	%	Optional
Optional	<b>DEG(J)</b>	Debris grease	N/A	Req'd	Req'd	%	Optional
Optional	<b>DES(J)</b>	Debris silt	N/A	N/A	N/A	%	Optional
Optional	<b>DH</b>	Deformed sewer, horizontal (brick sewers only)	N/A	N/A	N/A	%	Optional
Optional	<b>DI</b>	Dropped invert (brick sewer only)	N/A	N/A	N/A	N/A	Gap ... inches
Optional	<b>DV</b>	Deformed sewer, vertical	N/A	N/A	N/A	%	Optional
Optional	<b>EH(J)</b>	Encrustation heavy	N/A	Req'd	Req'd	%	Optional
Optional	<b>EL(J)</b>	Encrustation light	N/A	Req'd	Req'd	%	Optional
Optional	<b>EM(J)</b>	Encrustation medium	N/A	Req'd	Req'd	%	Optional
Optional	<b>ESH</b>	Scale heavy	N/A	Req'd	Req'd	%	Optional
Optional	<b>ESL</b>	Scale light	N/A	Req'd	Req'd	%	Optional
Optional	<b>ESM</b>	Scale medium	N/A	Req'd	Req'd	%	Optional

Collier Rd. Outfall Sewer Improvements – Phases 1 & 2  
Section 02752 – Internal Sewer Condition Assessment

Optional	<b>FC</b>	Fracture circumferential	N/A	Req'd	Req'd	N/A	Optional
N/A	<b>FH</b>	Finish Survey	N/A	N/A	N/A	N/A	Enter Finish MH Label
Optional	<b>FL</b>	Fracture longitudinal	N/A	Req'd	N/A	N/A	Optional
Optional	<b>FM</b>	Fractures multiple	N/A	Req'd	Req'd	N/A	Optional
N/A	<b>GO</b>	General observation at this point	N/A	N/A	N/A	N/A	Enter reason for general observation
N/A	<b>GOA</b>	General observation Abandonment of a Service Line Survey/Inspection	N/A	N/A	N/A	N/A	Enter reason for general abandonment and "D="
N/A	<b>GP</b>	General photograph number	N/A	N/A	N/A	N/A	Enter reason for general photograph
N/A	<b>H</b>	Hole in sewer	N/A	Req'd	Req'd	N/A	Indicate size of hole
Optional	<b>ID(J)</b>	Infiltration dripper	N/A	Req'd	Optional	N/A	Optional
Optional	<b>IG(J)</b>	Infiltration gusher	N/A	Req'd	Optional	N/A	Optional
Optional	<b>IR(J)</b>	Infiltration runner	N/A	Req'd	Optional	N/A	Optional
Optional	<b>IS(J)</b>	Infiltration seeper	N/A	Req'd	Optional	N/A	Optional
Optional	<b>JDL</b>	Joint displaced large	N/A	N/A	N/A	N/A	Optional
Optional	<b>JDM</b>	Joint displaced medium	N/A	N/A	N/A	N/A	Optional
N/A	<b>JN</b>	Junction	Req'd	Req'd	N/A	N/A	Enter Junction Material
N/A	<b>JNA</b>	Junction, abandoned	Req'd	Req'd	N/A	N/A	Optional
N/A	<b>JX</b>	Junction defective	Req'd	Req'd	N/A	N/A	Enter Junction Material and Defect Type
N/A	<b>JXA</b>	Junction defective abandoned	Req'd	Req'd	N/A	N/A	Enter Junction Material and Defect Type
N/A	<b>LC</b>	Lining of sewer changes/starts/finish es	N/A	N/A	N/A	N/A	Enter new lining or material code
N/A	<b>LD</b>	Line of sewer deviates down	N/A	N/A	N/A	N/A	Optional
Optional	<b>LL</b>	Line of sewer deviates left	N/A	N/A	N/A	N/A	Optional
Optional	<b>LN</b>	Lining defect	N/A	Req'd	Req'd	N/A	Optional
Optional	<b>LR</b>	Line of sewer deviates right	N/A	N/A	N/A	N/A	Optional
N/A	<b>LU</b>	Line of sewer deviates up	N/A	N/A	N/A	N/A	Optional
Optional	<b>MB</b>	Missing bricks	N/A	Req'd	Req'd	N/A	Indicate size of hole
N/A	<b>MC</b>	Material of sewer changes at this point	N/A	N/A	N/A	N/A	Enter new material
N/A	<b>MH</b>	Manhole/node	N/A	N/A	N/A	N/A	Enter the Start or Finish MH Label
Optional	<b>MM</b>	Mortar missing medium	N/A	Req'd	Req'd	N/A	Optional

Optional	<b>MS</b>	Mortar surface missing	N/A	Req'd	Req'd	N/A	Optional
Optional	<b>MT</b>	Mortar missing total	N/A	Req'd	Req'd	N/A	Optional
Optional	<b>OB(J)</b>	Obstruction	N/A	N/A	N/A	%	Enter the type of obstruction
Optional	<b>OJL</b>	Open joint large	N/A	N/A	N/A	N/A	Optional
Optional	<b>OJM</b>	Open joint medium	N/A	N/A	N/A	N/A	Optional
N/A	<b>PC</b>	Pipe Joint Length changes	N/A	N/A	N/A	N/A	Enter new pipe joint length, in feet
Optional	<b>RF(J)</b>	Roots fine (at joint)	N/A	Req'd	Req'd	N/A	Optional
Optional	<b>RM(J)</b>	Roots mass (at joint)	N/A	Req'd	Req'd	%	Optional
Optional	<b>RT(J)</b>	Roots tap (at joint)	N/A	Req'd	Req'd	N/A	Optional
N/A	<b>SA</b>	Survey abandoned	N/A	N/A	N/A	N/A	Enter Reason for abandoned survey
N/A	<b>SC</b>	Shape of sewer changes at this point	N/A	N/A	N/A	N/A	Enter code for new shape / other pertinent comments
Optional	<b>SSL</b>	Surface damage, spalling large	N/A	Req'd	Req'd	N/A	Optional
Optional	<b>SSM</b>	Surface damage, spalling medium	N/A	Req'd	Req'd	N/A	Optional
Optional	<b>SSS</b>	Surface damage, spalling slight	N/A	Req'd	Req'd	N/A	Optional
N/A	<b>ST</b>	Start of survey	N/A	N/A	N/A	N/A	Optional
Optional	<b>SWL</b>	Surface damage, wear large	N/A	Req'd	Req'd	N/A	Optional
Optional	<b>SWM</b>	Surface damage, wear medium	N/A	Req'd	Req'd	N/A	Optional
Optional	<b>SWS</b>	Surface damage, wear slight at	N/A	Req'd	Req'd	N/A	Optional
Optional	<b>V</b>	Vermin	N/A	N/A	N/A	N/A	Optional
Optional	<b>WL</b>	Water level	N/A	N/A	N/A	%	Optional
Optional	<b>X</b>	Sewer collapsed	N/A	N/A	N/A	%	Optional

## DEFECT CODES SORTED BY TYPE

### Pipe Material Codes:

AK	Alkathene
AC	Asbestos Cement
BR	Brick
CI	Cast Iron
SI	Spun Grey Iron
CMP	Corrugated Metal Pipe
CSB	Concrete Segment Bolted
CSU	Concrete Segment Unbolted
CO	Concrete
CC	Box Culvert
DI	Ductile Iron
GRC	Glass Reinforced Concrete
GRP	Fiberglass
PSC	Plastic / Steel Composition
PE	Polyethylene
PLP	PVC Fold & Form
PVC	PVC
RCP	Reinforced Concrete
RPM	Reinforced Plastic Matrix (Truss)
ST	Steel
VC	Vitrified Clay
PP	Polypropylene
WOD	Wood
PF	Pitch Fiber (Orangeburg)
MA	Masonry
XXX	Other (Comment)
ZZZ	Not Known

### Pipe Shape Codes:

A	Arched,
B	Barrel (Beer Barrel)
C	Circular
E	Egg Shape
H	Horseshoe
O	Oval
R	Rectangular
S	Square
T	Trapezoidal
U	U Shape w/ Flat Top
X	Other (Comments)

**Pipe Liner Codes:**

BL	Bitumin,
CPP	Cure In Place
CL	Cement,
IS	Soft Inversion,
PL	Plastic,
RL	Resin Liner,
XXX	Other,
ZZZ	Not Known

**Pipe Use Codes:**

C	Combined
F	Foul (Sanitary)
S	Surface Water
T	Trade Effluent
W	Watercourse (Culvert)
X	Other (Comment)
Z	Not Known

**Purpose Codes:**

A	Specific problems on sewer system related to structural or service condition
B	Specific problems on sewer system related to infiltration
C	Assessment of complete remedial or renovation works
D	Pre-adoption - normally new sewers for adoption
E	Pre-acceptance - new sewers (direct contract) constructed by sewerage undertakers
F	Sample survey to determine asset condition
G	Associated with future capital scheme including Drainage Area Planning
H	Resurvey for any reason
X	Other (state in Comments)
Z	Not Known

**Location:**

A	Main Road Urban
B	Main Road Rural
C	Lightly Traveled Road
D	Foot Path / Road Shoulder
E	Field
F	Garden
G	Woodlands
X	Difficult Access

**Weather Codes:**

1	Dry
2	Heavy Rain
3	Light Rain
4	Showers
5	Snow

[This page is intentionally blank]

## **ATTACHMENT D**

# **GENERAL INSPECTION LOGGING REQUIREMENTS**

[This page intentionally left blank]



## General reporting notes – Header Information

(to be read in conjunction with other related documentation, i.e. Clients Instructions or the Manual of Sewer Condition Classification):

- The Inspection company and the Inspectors name must be entered on the Header.
- The Date and accurate time of the inspection must also be recorded.
- Pipe sizes and shapes must also be recorded.
- **Recheck the accuracy of the Manhole Numbers and Road Names (for Road Names, i.e. 4711 Peachtree Street NE) as these are the “keys” to the whole inspection.**
- The Depth of the Start and Finish Manhole must be entered, but as a minimum, the Start Manhole depth is essential.
- A Total Length from center to center of manholes (Total Length Field) must be entered, either derived from the footage to the finish manhole (when the inspection successfully reaches the finish manhole) or estimated either from the Plan or by striding the length. It is fully understood that, in the case of an SA, the Total Footage is an estimate, **but it must not be the same as the Inspected length if SA.**  
If the Finish manhole cannot be found then enter a sensible footage (nominally 300 feet as an example) and NOT the footage of the abandonment. If the Total Length is estimated then just enter the text “Tot Length?” in Comments.
- If a Buried or Unmapped manhole is encountered then the Inspection report MUST finish with the MH / FH codes, and a new Inspection must be started. In the case of an unnumbered manhole being found, the numbering of the Manhole MUST be as advised by the client prior to the start of the Inspection/Contract.  
**Do not just make up a number. Update the map by marking the position of the Unmapped Manhole in red and writing its number in red.**
- If the inspection is abandoned from one direction and inspected from the other direction then the inspection from the first direction must be finished using SA **(plus a reason for the Inspection being Abandoned, SA)** and a new Header must be started for the “Reverse Inspection”. Note the reverse inspection by entering a “Y” in the proper field on line 1.
- If the inspection is not going to be carried out from the other Manhole, in the case of an SA, then a Header sheet MUST still be completed as if the inspection was to take place, with the reason for failing to carry out the inspection. **See the separate “No Access Instructions” appended to these guidelines.**
- Determine, prior to starting the contract, from Specification Section 02752, what text (data) must be displayed on the monitor (hence recorded). At the start of each inspection as much information as possibly needs to be recorded.
- **If using VHS tape, the video recorder MUST be set to SP and NOT EP or LP for the best quality** to be achieved especially if the Video is going to be encoded onto CD-ROM

**General reporting notes – Detail Information**

- The first three lines of each set of inspection details **must** have the codes ST, MH, and WL. **The Manhole Number must be entered in the Remarks column against the MH code** (this is essential as a number of Data Interrogation packages stores the Header and Detail records separately which are “connected” by an Index. To ensure data integrity, a QC check can be run against the Detail information to confirm that the correct Details are against the relevant Header).

i.e.: **V Digit Dist Code Remarks**  
**02305 0.0 ST**  
**0.0 MH SJ3425521**  
**0.0 WL 10**

- Each line of Detail must have the video digit (V Digit) entered against each code, presented in the following way:
  - The video digits must conform to the National elapsed time based standards (time into the tape) for Video Tape recorders:
    - Always have digits (hmmss).
    - Always right justified and zero filled.
    - The following elapsed time format **MUST** be adhered to, i.e.:  
**02305** is:  
**0** = Number of hours (Zero hours).  
**23** = Number of minutes (23 minutes).  
**0** = Units of 10 seconds each (0 seconds)  
**5** = Units of seconds (5 seconds).
  - Other examples:  
 00324 = 3 minutes and 24 seconds into the tape.  
 15039 = 1 hour, 50 minutes and 39 seconds into the tape.  
 24516 = 2 hours, 45minutes and 16 seconds into the tape.

This method locates the position of the defect/feature into the tape to within a few seconds, which is more than adequate.

- The final detail line for each inspection **MUST** end with a Termination code, either SA (Survey Abandoned) or FH (Survey Finished).

i.e. **24511 76.0F1FL 12**  
**24511 76.0 RMJ 30**  
**24511 76.0 SA DUE TO ROOTS MASS (or DUE TO RMJ)**  
 ----- or -----  
**14956 97.3 D 10**  
**15032 102.9 MH SJ35513464**  
**15032 102.9 FH**

***Each Inspection Report MUST only contain one Inspection hence, in the case of a Survey Abandonment or a buried or unmapped manhole being encountered, a new Header and Detail must be completed.***

***The above are essential for the Validation of the data to take place and to tie the data in with Mapping systems.***

## General reporting notes – Detail Information (Cont'd)

When a defect or feature is encountered, the camera must be stopped just prior to the defect/feature so that it can be clearly seen.

- The defect/feature must be recorded for a sufficient time to enable the engineer to assess the observation without recourse to using the “pause” facility.
- A video digit must be entered against the defect/feature in the format of time elapsed into video tape. The format is :h:mm:ss (explained above).
- If the defect spans for more than 3 feet or is repetitive over a number of joints (i.e. ELJ, Encrustation Light at Joint) then a Start Flag (S1, S2 etc, sequentially up to S9 then SA, SB --- SZ! can be used) can be entered against the code at the start footage. When the defect finishes the appropriate Finish Flag is inserted against the defect at the finish footage and the same Flag number is used to finish the defect off (S1 MUST finish with an F1 and so on). This aids the Rig Manager in reporting repeating defects without having to enter the code at every joint footage or every 3 feet.

**Note: The defect that has the start flag against it can change its position (i.e. a FL or CL) but not its magnitude (i.e. you cannot start with a CL and finish with a FL. You must “close”, or finish, the defect with the appropriate Finish Flag and then start the new defect with an UNUSED (in the current inspection) Start Flag.**

- If the inspection was abandoned (SA), then a reason for the abandonment MUST be entered in the Remarks column against the SA code. The description of the reason for the SA should contain the appropriate defect code that has caused the abandonment (i.e. If due to an intruding connection then the end of the report would read:

```
11025  342.8  CNI  04  11  02
11025  342.8  SA           DUE TO CNI
```

- If you are unsure of the defect magnitude (an FL or CL, for instance) then enter the worst code of the two, with its support information, and then in Remarks enter: CL ??

```
i.e. 00327  301.2  FL      11      CL??
```

- All defects and features MUST have the relevant support data (i.e. JN/CN must have sizes and positions. See Defect Code list for details)

## General Inspection Logging Requirements

(to be read in conjunction with other related documentation, i.e. Manual of Sewer Condition Classification):

The first three lines of each set of survey details **must** have the codes ST, MH, and WL (WL is optional but is important to the City of Atlanta as it directly relates to the sewer flow level at a certain time of day).

The Manhole Number must be entered in the Remarks column against the MH code (this is essential as a number of Data Interrogation packages stores the Header and Detail records separately which are “connected” by an Index. To ensure data integrity, a QC check can be run against the Detail information to confirm that the correct Details are against the relevant Header).

i. e.:

```
OD10230  0.0 ST
OD1      0.0 MH      SJ34255521
OD1      0.0 WL      10
```

Each line of Detail (or as a minimum the first and last Detail lines) must have the video digit entered against each code, presented in the following way:

– The video digits must conform to the National elapsed time based standards (time into the tape) for Video Tape recorders:

- Always four digits (hmms, where s = units of 10 seconds).
- Always right justified and zero filled.
- The following elapsed time format **MUST** be adhered to, i.e.:

0230

0 = Number of hours (Zero hours).

23 = Number of minutes (23 minutes).

0 = Units of 10 seconds each (0 seconds).

Other examples:

0032 = 3 minutes and 20 seconds into the tape.

0244 = 24 minutes and 40 seconds into the tape.

1503 = 1 hour, 50 minutes and 30 seconds into the tape.

2451 = 2 hours, 45minutes and 10 seconds into the tape.

**The final detail line for each survey must end with a Termination code, either SA or FH.**

i.e.

```
OD1      89.0 RMJ      30
OD1      89.0F1JDS
OD10410  89.0 SA      DUE TO ROOTS MASS
----- or -----
OD1      33.0 D      10
OD1      34.9 MH      SJ35513464
OD10670  34.9 FH
```

**Each Survey Report MUST only contain one survey hence, in the case of Survey Abandonment or a buried or uncharted manhole being encountered, a new Header and Detail must be completed. The above are essential for the Validation of the data to take place**

[This page intentionally left blank]

**DRAFT**  
**CITY OF ATLANTA – INTERNAL CONDITION ASSESSMENT LOG**

CD Volume Label	Contractor/Inspector	Basin Number	Sub Basin Number	Reverse	Spare	PLR
<input type="text"/>	<input type="text"/>	<input type="text"/>	<input type="text"/>	<input type="text"/>	<input type="text"/>	<input type="text"/>

Date (mmddyy)	Time	Address ( Street Number, NSEW, Name, Type, NSEW, Apt #)				Outfall / Trunk Name
<input type="text"/>	<input type="text"/>	<input type="text"/>	<input type="text"/>	<input type="text"/>	<input type="text"/>	<input type="text"/>

Start Manhole	Start Depth	Start Cover	Start Invert	Finish Manhole	Finish Depth	Finish Cover	Finish Invert
<input type="text"/>	<input type="text"/>	<input type="text"/>	<input type="text"/>	<input type="text"/>	<input type="text"/>	<input type="text"/>	<input type="text"/>

Use	Direction	Size 1 Dia/Hght	Size 2 Width	Shape	Material / Lining	Pipe Length	Total Length	Year Laid
<input type="text"/>	<input type="text"/>	<input type="text"/>	<input type="text"/>	<input type="text"/>	<input type="text"/>	<input type="text"/>	<input type="text"/>	<input type="text"/>

Video Name	Spare	Comments
<input type="text"/>	<input type="text"/>	<input type="text"/>

Purpose	Weather	Location	Location Details	Category Code	Pre-Cleaned
<input type="text"/>	<input type="text"/>	<input type="text"/>	<input type="text"/>	<input type="text"/>	<input type="text"/>

Video No.	Photo.No./S VC.No	Distance	Cont. Defect	Code	Diameter	Circumferential		Percent / Intrusion	Remarks
						Clock At	Clock To		
<input type="text"/>	<input type="text"/>	<input type="text"/>	<input type="text"/>	<input type="text"/>	<input type="text"/>	<input type="text"/>	<input type="text"/>	<input type="text"/>	<input type="text"/>
<input type="text"/>	<input type="text"/>	<input type="text"/>	<input type="text"/>	<input type="text"/>	<input type="text"/>	<input type="text"/>	<input type="text"/>	<input type="text"/>	<input type="text"/>
<input type="text"/>	<input type="text"/>	<input type="text"/>	<input type="text"/>	<input type="text"/>	<input type="text"/>	<input type="text"/>	<input type="text"/>	<input type="text"/>	<input type="text"/>
<input type="text"/>	<input type="text"/>	<input type="text"/>	<input type="text"/>	<input type="text"/>	<input type="text"/>	<input type="text"/>	<input type="text"/>	<input type="text"/>	<input type="text"/>

CD Volume Label	Contractor/Inspector	Date	Time	PLR
-----------------	----------------------	------	------	-----

Video No.	Photo No.	Distance	Cont. Defect	Code	Diameter	<u>Circumferential</u> Clock At    Clock To		Percent / Intrusion	Remarks



# **ATTACHMENT E**

## **SERVICE LATERAL DOCUMENTATION**

[This page intentionally left blank]

**Launch From Main:**

<b>CD Volume Label</b> PTO1XXAGCT01	<b>Contractor/Inspector</b> AG CT	<b>Basin Number</b> PTC	<b>Sub Basin Number</b> 01	<b>Reverse</b> 	<b>Spare</b> 	<b>PLR</b> 23260112301
--	--------------------------------------	----------------------------	-------------------------------	--------------------	------------------	---------------------------

<b>Date (mmddy)</b> 90502	<b>Time</b> 1245	<b>Address ( Street Number, NSEW, Name, Type, NSEW, Apt #)</b> 1234 PEACHTREE RD NE				<b>Outfall / Trunk Name</b> 
------------------------------	---------------------	--	--	--	--	---------------------------------

<b>Start Manhole</b> 23260112301	<b>Start Depth</b> 6.00	<b>Start Cover</b> 	<b>Start Invert</b> 	<b>Finish Manhole</b> 23260123401	<b>Finish Depth</b> 6.00	<b>Finish Cover</b> 	<b>Finish Invert</b> 
-------------------------------------	----------------------------	------------------------	-------------------------	--------------------------------------	-----------------------------	-------------------------	--------------------------

<b>Use</b> F	<b>Direction</b> D	<b>Size 1 Dia/Hght</b> 8	<b>Size 2 Width</b> 	<b>Shape</b> C	<b>Material</b> CO	<b>Lining</b> 	<b>Pipe Length</b> 3	<b>Total Length</b> 70.3	<b>Year Laid</b> 
-----------------	-----------------------	-----------------------------	-------------------------	-------------------	-----------------------	-------------------	-------------------------	-----------------------------	----------------------

<b>Video Name</b> 00000	<b>Spare</b> 	<b>Comments</b> 
----------------------------	------------------	---------------------

<b>Purpose</b> B	<b>Weather</b> 1	<b>Location</b> B	<b>Location Details</b> 	<b>Category Code</b> 	<b>Pre-Cleaned</b> N
---------------------	---------------------	----------------------	-----------------------------	--------------------------	-------------------------

Video No.	Photo/Svc No.	Distance	Cont.		Diameter	Circumferential		Percent / Intrusion	Remarks
			Defect	Code		Clock At	Clock To		
10020		0.0		ST					
10020		0.0		MH					23260112301
10110	01	22.1		JN	4	12			INSPECTION FROM CLEANOUT
10202	02	35.2		CN	4	11			SVC INSPECT
11030	03	50.6		CN	4	09			SVC INSPECT
11655		70.3		MH					23260123401
11655		70.3		FH					

**From Clean Out:**

<b>CD Volume Label</b>	<b>Contractor/Inspector</b>	<b>Basin Number</b>	<b>Sub Basin Number</b>	<b>Reverse</b>	<b>Spare</b>	<b>PLR</b>
CCO1XXCECN01	CE CN	CMC	01			23260112301

<b>Date (mmdyy)</b>	<b>Time</b>	<b>Address ( Street Number, NSEW, Name, Type, NSEW, Apt #)</b>					<b>Outfall / Trunk Name</b>
90502	1245	1268		PEACHTREE	RD	NE	

<b>Start Manhole</b>	<b>Start Depth</b>	<b>Start Cover</b>	<b>Start Invert</b>	<b>Finish Manhole</b>	<b>Finish Depth</b>	<b>Finish Cover</b>	<b>Finish Invert</b>
23260112301_01	6.00			23260123401	6.00		

<b>Use</b>	<b>Direction</b>	<b>Size 1 Dia/Hght</b>	<b>Size 2 Width</b>	<b>Shape</b>	<b>Material / Lining</b>	<b>Pipe Length</b>	<b>Total Length</b>	<b>Year Laid</b>
F	D	4		C	VC	3	55	

<b>Video Name</b>	<b>Spare</b>	<b>Comments</b>
00001		

<b>Purpose</b>	<b>Weather</b>	<b>Location</b>	<b>Location Details</b>	<b>Category Code</b>	<b>Pre-Cleaned</b>
B	1	F	=SERVICE LINE=		N

Video No.	Photo/Svc No.	Distance	Cont. Defect	Code	Diameter	Circumferential		Percent / Intrusion	Remarks
						Clock At	Clock To		
10020		0.0		ST					
10020		0.0		MH					23260112301_01 (CO)
10320		55		FH					MAIN LINE REACHED

## **ATTACHMENT F**

# **SEWER1.DAT DATA SPECIFICATION AND EXAMPLE OF SEWER1.DAT DATA FILE**

[This page intentionally left blank]

## **CCTV data transfer: Sewer1.Dat Description and Inspection Guidelines**

### Overview:

*The Sewer1.dat Inspection data transfer format has been in existence since 1984. Sewer1.dat has been developed because the technology available now means that longer lengths are being inspected resulting in the need for higher “numbers” being achieved and longer manhole identifiers are becoming the “norm”. Sewer1.dat reflects these needs.*

*Sewer1.dat is an “open architecture” format and was devised by a UK Government body called WRc to ensure that inspection data could be transferred between many applications and that no one contractor or software supplier had monopoly on inspection data input/interrogation software.*

*Sewer1.dat format basis is derived from the site data input form found in the Manual of Sewer Condition Classification Ver. 2 and 3. without the guideline boxes. Copies of the Manual are easily available. The form has been further customized for the City of Atlanta’s specific needs following the same general format.*

*There are at least 15 specialist software programs around worldwide that accepts this format, and can be imported into ACCESS, Dbase V (with the Sewer1.dat fields properly defined within such applications) and Geographical Information Systems. The specification for the format is “free issue” and devoid of “control characters” that can be found in some bespoke applications/data transfer specs.*

*A number of companies offer a free service to Contractors who wish to export to the Sewer1.dat format from their data handling software to test the correctness of the format and offer advice when necessary.*

To ensure that the data transfer file format is correct the following points are to be adhered to:

- Some Field labels are available for the Contractor’s use for their own purpose. These are labeled “Spare”.
- The file is to be in a standard ASCII text format (i.e. no control characters) therefore each line in the file should be terminated by an ASCII carriage return/linefeed combination i.e. ASCII code 13 followed by ASCII code 10 (the default termination on most text generating programs).
- *The maximum line length must not exceed 81 characters including the ASCII termination code, except for Line 1 where the contractor can have their own reference after the 80<sup>th</sup> character. Other information could be added after the last character in each line (except for Line 1) if the software that the data is going into is set up to import this extra data. Line 2, for instance, the position from character 64 to 81 is unused.*

- Decimal points must not be in any header field. The Format describes the mask of the field; the Actual Format shows how it should have been originally recorded/reported.
- Each Header line must start with a three character identifier "1Hn", *n* being between 1 and 6. The "1" before the "H" denotes that it is a **Sewer1.dat** specification.
- Each Detail line must start with a three character identifier "1D1". The "1" before the "D" denotes that it is a **Sewer1.dat** specification.
- Decimal points must be in Detail footage.
- N = Numeric ONLY field. If the Format is unspecified then Alpha Numeric characters are acceptable.



## DATA TRANSFER SPECIFICATION

		<b>Start Position</b>	<b>Number of Characters</b>	<b>Format/Actual Format -----Or Notes-----</b>
-				
<b>Line 1</b>	"1H1"	1	3	Line Identifier
	CD Volume Label	4	12	As per City Guidelines
	Contractor/Inspector	16	8	*-----Ditto-----
	Basin Number	24	10	*i.e. PTC or PTC-PRC
	Sub Basin Number	34	10	*i.e. 32/33/34
	Reverse		44	1 Indicate Y if reverse setup
	Spare	45	3	For Contractors Use
	PLR	48	17	Upstream Mh No. + X or
	Y			

**\* Specific format and Information supplied by City of Atlanta**

<b>Line 2</b>	"1H2"	1	3	Line Identifier
	Date	4	8	MMDDYYYY
	Time	12	4	hhmm
	Road Name	16	30	Where Upstream Mh
is.**	Place Name	46	20	Local name

**\*\* Specific format and Instructions for completion to be supplied by City of Atlanta**

<b>Line 3</b>	"1H3"	1	3	Line Identifier
	Start Manhole	4	16	
	Start Depth	20	5	(NNNNN)(nnn.nn)
	Start Cover	25	6	(NNNNNN)(nnnn.nn)
	Start Invert	31	6	(NNNNNN)(nnnn.nn)
	Finish Manhole	37 (was 38)	16	
	Finish Depth	53	5	(NNNNN)(nnn.nn)
	Finish Cover	58	6	(NNNNNN)(nnnn.nn)
	Finish Invert	64	6	(NNNNNN)(nnnn.nn)
<b>Line 4</b>	"1H4"	1	3	Line Identifier
	Use	4	1	
	Direction	5	1	Direction of inspection
U/D	Size 1	6	4	(NNNN)(nnnn)
	Size 2	10	4	(NNNN)(nnnn)
	Shape	14	1	
	Material	15	3	
	Lining	18	3	
	Pipe Length	21	4	(NNNN)(nnn.n)
	Total Length	25	5	(NNNNN)***(nnnn.n)
	Year Laid	30	4	

**\*\*\* Distance between the St. and Fh. Manholes, NOT inspected length unless the inspection was completed where it would be the same as the Inspected length.**

<b>Line 5</b>	"1H5"	1	3	Line Identifier
---------------	-------	---	---	-----------------

	Video Name	4	5	e.g. 00000, 00001, etc.
	Spare	9	10	
	Comments	19	40	
<b>Line 6</b>	"1H6"	1	3	Line Identifier
	Purpose	4	1	
	Weather	5	1	
	Location	6	1	
	Location Details	7	50	
	Category Code	57	1	
	Pre-Cleaned	58	1	
<b>Details</b>	"1D1"	1	3	Line Identifier
	Video Digit.	4	5	(NNNNN)(nnnnn)
	Photo/Svc No. (see Note 2.)	9	4	(NNNN)(nnnn)
	Distance	13	6	(NNNN.N)(nnnn.n)
	CD	19	2	Cont. Defect column
	Code	21	5	
	Diameter	26	4	(NNNN)(nnnn)
	Clock At	30	2	(NN)(nn)
	Clock To	32	2	(NN)(nn)
	<b>*Percentage %</b>	34	2	(NN)(nn)
	<b>*Intrusion</b>	34	4	(NNNN)(nnnn)
	Remarks	38	30	

**\*Note:** The position from character 29 to 32 is a shared field in that there is no defect or feature that would have both Percentage and Intrusion, hence if a Percentage the Start position would be 29 for two characters (99% max), and if an Intrusion the Start position would also be 29 but zero filled (20 inches would be 0020, for instance).

Note 2. In addition to the standard use as described in the Manual of Sewer Condition Classification, this field will also be used to number service connections/junctions in accordance with the attached clarification on CCTV Inspection of Private Service Connections and Junctions.

## Example of Sewer1.Dat Data File on Diskette

```
1H1CC02BXCECN02CECN CMC 02B 13930201601
1H20829200209162731 BLACK FOREST TR SW
1H313930201601 00915 13930201701 01427
1H4FD0008 CCO 004001881
1H5C0003
1H6B1B N
1D100027 0000.0 ST
1D100057 0000.0 MH MANHOLE 13930201601
1D100113 0000.0 WL 05
1D100532 0002.3 JN 000603 MATERIAL CO
1D100942 0005.1 JN 000609 MATERIAL CO
1D101253 0046.0 ELJ 070805
1D101427 0049.6 B 0304
1D101511 0051.4 JN 000603 MATERIAL CO
1D101619 0052.7 JDM 0105
1D101759 0068.5 FL 12
1D101924 0076.2 ELJ 010205
1D102056 0095.9 ELJ 030505
1D102214 0098.8 CX 000611 MATERIAL CO
1D102345 0105.1 JNA 000609 MATERIAL CO
1D102607 0138.3 FL 12
1D102713 0148.3 FL 12
1D102816 0159.6 JN 000603 MATERIAL CO
1D103002 0182.2 JX 000609 MATERIAL CO
1D103127 0188.1 MH MANHOLE 13930201701
1D103151 0188.1 FH
```

END OF SECTION

[This page intentionally left blank]

---

**SECTION 02757****Point Repair of Sanitary Sewers****PART 1 – GENERAL****1.01 SCOPE**

- A. This Section describes repairs to sections of existing sanitary sewers that require correction of isolated major defects, misalignments or collapses.
- B. External Point repairs include necessary external corrective action by means of open cut trench pipe replacement/renewal construction, both as an independent solution to a specific problem or to facilitate other rehabilitation methods such as pipe-bursting or lining.
- C. Internal Point Repairs include necessary internal corrective action using a short length tightly fitting cured-in-place (CIPP) liner for the local repair of an isolated defect or several adjacent defects that can be encompassed within the material length of an internal CIPP point repair within a sanitary sewer pipeline. The liner shall be smooth, hard, strong, chemically inert and free from blemishes.
- D. Furnish all products and perform all labor necessary to fulfill the requirements of these Specifications.

**1.02 APPLICABLE REHABILITATION METHODS**

- A. This specification applies to the following repair methods, varying only in length and purpose of repair as described below.
  - 1. Pipe Blockage External Point Repair - This rehabilitation method is for correcting a major offset, blockage or other type of restriction of a pipeline that would reasonably impede or prohibit pipe-bursting or push-bursting operations. Pipe Blockage Repair includes excavation, maintaining the trench until the new HDPE piping is in place after pipe-bursting, backfill and site restoration.
  - 2. Sanitary Sewer Sag External Point Repair - This rehabilitation method is for correcting a sag in a mainline so that pipe-bursting, horizontal directional drilling or push-bursting may proceed to line and grade. A Sag Repair means correcting a sag in a segment of pipeline where the lowest point of the “Sag” is subject to ponding that is greater than 25% of the diameter of the pipeline. Sag Repair includes excavation, maintaining the trench until the new piping is installed, backfill and site restoration including disposal of all excavated waste material.

3. External Point Repair - This rehabilitation method is for correcting a defect on a mainline that requires excavation. Pipe defect(s) may include collapsed pipe (>10% deformation), severely broken pipe, major dropped joint, major offset joint, or a severely defective service line connection. This type of repair shall include excavation, replacing a section of pipe up to sixteen (16) linear feet in length; replacing up to one (1) service connection, installation of flexible repair couplings or boots as applicable, backfill, disposal and site restoration

All pipe and fittings furnished for this work must comply with the requirements of Section 02730 of the Contract Documents. The replacement pipe section shall be the same size and material as the existing pipe unless the existing pipe is vitrified clay. In such case, PVC shall be used as the pipe section material unless otherwise directed by the Engineer.

It is the Contractor's sole responsibility to establish elevation and/or survey controls necessary to attain true line and grade for the replacement pipe section for all External Point Repairs. No abrupt deflections in line or grade will be allowed.

4. Internal CIPP Point Repair - This rehabilitation method is for correcting a defect on a mainline that can be rectified internally. Pipe defect(s) may include multiple cracks, fractures, deformed pipe (<10% deformation), minor dropped joint, minor offset joint, or a minor defective service line connection. This type of repair shall include lining a limited section of pipe up to seven (7) linear feet in length. Several internal point repairs may be installed in a single segment (length of sewer between manholes) to be determined by the Engineer.

All pipe and fittings furnished for this work shall comply with the requirements of Section 02730 of the Contract Documents.

- B. Point repairs are made at specific locations and involve relatively short lengths of sewer. Isolation of affected reaches of sewer, by plugging and/or bypass pumping if required, shall be performed in accordance with Section 02750 of the Contract Documents.
- C. After each designated Point Repair has been made, the Contractor will perform a CCTV inspection in accordance with Section 02752. The CCTV video and inspection report will be submitted to the City for review. The cost of the CCTV inspection shall be included in the unit price for the Point Repair. If a repaired joint or section should subsequently prove to be defective, the Contractor shall re-perform the work at no additional cost to

the City and shall also be responsible for the costs of any re-inspection required by the City to document the success of the re-work.

- D. Excavation, backfill, resolution of conflicts with other utilities, and miscellaneous work shall conform to the requirements of Sections 02730 and 02200 of the Contract Documents as appropriate.

### 1.03 SUBMITTALS

- A. The Contractor shall submit shop drawings for external point repair pipe material, couplings, CIPP point repair material and delineate staging, traffic control, and access arrangement when the complexity of the repair warrants, as determined by the Engineer and in accordance with Section 01340 of the Contract Documents **(30 Calendar Days before the Point Repair)**.
- B. All internal CIPP point repair submittals shall comply with the related requirements of Section 02520.
- C. Pre installation CCTV inspection reports and videos. Pre installation reports and videos shall be provided no later than 30 calendar days before the point repair installation **(30 Calendar Days before the Point Repair)**.
- D. Post installation CCTV inspection reports and videos. Post installation reports and videos shall be provided within 10 calendar days after the point repair and reinstatement of all laterals **(Within 10 Calendar Days of the Point Repair)**.

## PART 2 – PRODUCTS

### 2.01 PIPE AND PIPE FITTINGS

- A. All pipe and fittings for external point repairs shall be PVC, reinforced concrete pipe (RCP) or ductile iron pipe (DIP) as specified in Section 02730.
- B. All related sections for internal CIPP point repairs, materials, specifications, trial tests, warranty and standards for CIPP point repairs shall comply with the requirements of Section 02520, where applicable with the exception that only epoxy resins shall be used with internal CIPP point repairs.

## **PART 3 – EXECUTION**

### **3.01 GENERAL**

- A. The Contractor shall furnish all labor, tools, materials, and equipment necessary for installation and jointing of the pipe. All piping and lining shall be installed in accordance with the Contract Documents in a neat workmanlike manner and shall be set for accurate line and elevation. All piping shall be thoroughly cleaned before installation, and care shall be taken to keep the piping clean throughout the installation.

### **3.02 PREPARATION**

- A. Flow Control: Flow control shall be exercised as required to ensure that no flowing sewage comes into contact with sections of the sewer under repair or replacement in accordance with Section 02750 of the Contract Documents.
- B. Preconditioning and Cleaning (Manholes and) Sewer – Prior to installation of the CIPP point repair the entire sewer shall be preconditioned and cleaned in accordance with the requirements of Section 02511. Installation of CIPP point repair shall not proceed without the Engineers written permission.
- C. The engineers permission to proceed will be contingent on the acceptance of an internal condition assessment video of the prepared sewer to confirm that the sewer is free from all debris and inherent conditions that may adversely affect the smooth introduction of the CIPP point repair into the sewer to be repaired. The internal condition assessment shall accurately portray the position of defects and laterals affected by the proposed remediation. Any lateral introduced into the sewer being treated at the location of the CIPP point repair shall be introduced within the middle third of the repair. Internal condition assessment prior and post lining shall be included in the cost of the repair.

## **REQUIREMENTS SPECIFIC FOR THE CONSTRUCTION OF EXTERNAL POINT REPAIRS.**

### **3.03 REMOVAL AND REPLACEMENT OF SEWER**

- A. After the limits of a particular portion of the existing sewer have been established on the ground, operations shall progress generally as follows:



1. Carefully remove or protect surface features in work area. Expose a full section of existing pipe, including the joints at each end. Take adequate precautions not to disturb any other existing underground facilities. Handle all excavated materials as described in Section 02200 of the Contract Documents.
2. That section of pipe to be replaced shall be isolated by plugging and/or bypass pumping as described in Sections 02750 of the Contract Documents, or by any other method proposed by the Contractor and acceptable by the City.
3. After the defect is located and exposed, the defective pipe or fitting shall be removed by cutting each side along lines perpendicular to longitudinal axis of pipe so as to leave "spigot ends" to be connected to replacement pipe and dispose of the existing pipe and concrete encasement, if any.
4. Excavate the trench to a minimum of 8-inches below the proposed pipe bottom, place bedding material in the trench and shape to form continuous uniform support for the pipe barrel.
5. Pipe shall be installed and jointed, normally beginning at its low or outlet end and proceeding upstream, with the bell ends facing upstream toward the direction of flow. Make connections to existing manholes or existing pipe remaining in place. Install wyes or tees, with branches temporarily plugged, to make reconnections to existing service laterals, if any. Complete bedding or encasement and place compacted backfill as necessary to avoid flotation if water should enter the trench. Encasement will only be allowed if the Engineer confirms that future pipe-bursting will not be required.
6. Complete placement and compaction of backfill. For purposes of the external point repair, the material excavated is considered suitable backfill, provided the excavated material meets the requirements of section 02200 for suitable backfill.
7. Restore surface features to at least as good condition as existed before construction began, including landscaping, grass, roadways, driveways and walks.
8. For External Point Repairs only, perform leakage test in accordance with Section 02730.

### **3.04 EXCAVATION AND BACKFILL**

- A. The Contractor shall excavate and backfill in accordance with Section 02200 of the Contract Documents. Under no circumstances shall the

Contractor be allowed to remove concrete or asphalt without prior saw cutting. The saw cutting shall be deep enough to produce an even, straight cut.

### **3.05 LAYING PIPE**

- A. Proper and suitable tools and appliances for the safe convenient handling and laying of pipe shall be used and shall, in general, agree with manufacturer's recommendations. At the time of laying, the pipe shall be examined carefully for defects, and should any pipe be discovered to be defective after being laid, it shall be removed and replaced with sound pipe by the Contractor at his expense.
- B. Upon satisfactory completion of the pipe bedding, a continuous trough for the pipe barrel and recesses for the pipe bells, or couplings, shall be excavated by hand digging. When the pipe is laid in the prepared trench, true to line and grade, the pipe barrel shall receive continuous, uniform support and no pressure shall be exerted on the pipe joints from the trench bottom.
- C. Pipe shall be installed in accordance with the manufacturer's recommendation. Before being lowered into the trench, the pipes and accessories shall be carefully examined and the interior of the pipes shall be thoroughly cleaned of all foreign matter and other methods acceptable to the City.
- D. Lines shall be laid straight and depth of cover shall be maintained uniform with respect to finish grade, whether grading is completed or proposed at time of pipe installation. No abrupt changes in direction or grade will be allowed.
- E. After pipe has been laid, reviewed and found satisfactory, sufficient backfill shall be placed along the pipe barrel to hold the pipe securely in place during the test. No backfill shall be placed over the joints until the test is satisfactorily completed, leaving the exposed joints to view for the detection of visible leaks. Upon satisfactory completion of the test, backfilling of the trench shall be completed.

### **3.06 INSTALLATION OF PIPE**

- A. PVC, RCP and DIP shall be installed in accordance with Section 02730.

### **3.07 PIPE-TO-PIPE CONNECTIONS**

- A. Pipe-to-pipe connections shall be made in accordance with Section 02730 by using flexible banded couplings or adapters, couplings with compression joints in compliance with ASTM C 425.

### **3.08 PIPE-TO-MANHOLE CONNECTIONS**

- A. When a sound pipe stub-out exists from a manhole to which connection is to be made, a pipe-to-pipe connection shall be made as described above. If one is not present or is faulty, an opening shall be cut in the manhole wall and the connection, consisting of a pipe stub-out with an EPDM rubber boot assembly grouted into the opening with non-shrink grout shall be made to form a corrosion resistant, watertight seal. The invert, benches and floor inside the manhole shall be cut and reshaped as necessary.

### **3.09 TELEVISION INSPECTION**

- A. Post Construction CCTV inspection in accordance with Section 02752 of the Contract Documents is required for all Internal and External Point Repairs on sanitary sewers. The post-installation CCTV inspection shall take place as shortly after completion of each section as is feasible, but in no case more than ten (10) calendar days thereafter. The contractor is required to submit the post-installation CCTV videos within ten (10) calendar days of completing the rehabilitation of a segment of the sewer. The repairs shall demonstrate the full and effective rectification of the extant defect and/or obstruction, including infiltration etc., to the complete satisfaction of the Engineer. The Post Construction CCTV inspection is not required for Pipe Blockage Repairs or Sanitary Sewer Sag Repairs performed prior to pipe-bursting or pipe replacement.

### **3.10 TRAFFIC CONTROL**

- A. Refer to Specification Section 01500: Temporary Control of Construction Operations for requirements.

END OF SECTION

[This page intentionally left blank]

---

**SECTION 02900**

**Landscaping**

**PART 1 – GENERAL**

**1.01 SCOPE**

- A. The Contractor shall provide landscaping and appurtenant work, complete and in place, in accordance with the Contract Documents. All existing landscaping features and products removed or damaged in the performance of the Work shall be restored to original condition or better.
- B. Trees and shrubs removed or damaged in the performance of the Work shall be replaced with plantings of the same species and equivalent diameter-inch.

**1.02 DEFINITIONS**

- A. The terms "plant material" or "plants" refer to all vegetation, whether trees, shrubs, ground cover, or herbaceous vegetation.
- B. "Quality" refers to structure and form, as evidenced by density and number of canes and branches, compactness, symmetry, and general development without consideration of size or condition. "Standard quality" indicates the least acceptable quality. "Standard quality" plants shall be typical of the species and variety of good average uniform growth, shall be well formed and uniformly branched, and shall have the minimum number of canes indicated, free from irregularities, or shall conform to minimum quality index. Where the number of canes is not specifically stated in describing this grade, the "Horticultural Standards" as adopted by the American Association of Nurserymen shall apply. In such a case, the number of canes and other factors for the appropriate classification under "quality definition" in the Horticultural Standards shall be the Quality Index. Plant material below this standard will be considered "culls" and are not acceptable. Plants shall be nursery grown.
- C. "Specimen" means an exceptionally heavy, symmetrical, tightly-knit plant, so trained or favored in its development and appearance as to be outstanding, superior in form, number of branches, compactness, and symmetry.
- D. "Size" is the factor controlled by dimensions representing height or spread, or both, without consideration of quality or conditions. For

standard quality, a dimension is given for height or container size, or a dimension is given for height as well as container size.

- E. "Height" is usually indicated with a tolerance. The smaller dimension is the minimum acceptable. The larger dimension represents the maximum permissible. The average dimension of all plants shall equal the average of the tolerance figures for each item.
- F. "Condition" is the factor controlled by vitality and ability to survive, thrive, and be comparable with normal plants of the same species and variety in the vicinity at the same season of the year. Plants shall be free from physical damage or adverse conditions that would prevent thriving. "Condition" also sometimes refers to state of growth, i.e., whether "dormant condition" or "growing condition," and this state shall be comparable to plants of similar species in the vicinity for leaves, formation of buds, and the like.
- G. "Cane" means a primary stem which starts from the ground, or close to the ground, at a point not higher than 1/4 the height of the plant.
- H. "Caliper" shall be measured 12 inches above the finish grade or ground, as a guide, or where the trunk appears to form the head of the tree.
- I. "Foliage line" is maximum dimension in case of specimen plants. It measures from ground to lowest part of body of plant.

### **1.03 REFERENCE SPECIFICATIONS, CODES, AND STANDARDS**

A. Federal Specifications:

- 1. FS O-F-241DFertilizer, Mixed, Commercial

B. Commercial Standards:

- 1. ASTM D 422 Method for Particle-Size Analysis of Soils
- 2. ANSI Z60.1 Nursery Stock
- 3. American Association of Nurserymen, Inc.
- 4. Rules and Grading Provisions

### **1.04 CONTRACTOR SUBMITTALS**

- A. General: Submittals shall be furnished in accordance with General Conditions, Section 28.

B. Product Information:

1. Manufacturer's product information on fertilizer, peat moss, mulch, seed mixtures, sod, and tree paint.
2. Topsoil Analysis Report: A report certified by an analytical laboratory that shows results of analyzing representative samples of topsoil proposed for use. Approval of the report does not constitute final acceptance of the topsoil.

C. Certificate:

1. Certificates shall accompany each delivery stating source, quantity, and type of material. All certificates shall be submitted at the time of delivery.
2. Certificates of inspection of plant material, as may be required by federal, state, or other authorities having jurisdiction, which accompany the shipment, shall be submitted at delivery.

**1.05 QUALITY ASSURANCE**

- A. General: All plants shall be true to type or name as indicated in the Contract Documents and shall be tagged in accordance with standard practice; however, determination of plant species or variety will be made by the Engineer.
- B. All plants shall comply with federal and state laws requiring inspection for plant diseases and infestations.
- C. Inspections will be made by the Engineer or its representative. The Contractor shall request inspection at least 24 hours in advance of the time inspection is required. Inspection is required on the following stages of the Work:
1. During preliminary grading, soil preparation, and initial weeding.
  2. When trees are spotted for planting, but before planting holes have been excavated.
  3. When finish grading has been completed.
  4. When all Work except the maintenance period has been completed.
  5. Final inspection at the completion of the maintenance period.

- D. Plants shall be subject to inspection and approval or rejection by the Engineer at place of growth and upon delivery to the Site at any time before or during progress of the Work based on:
  - 1. Quantity, quality, size, and variety;
  - 2. Ball and root condition; and
  - 3. Latent defects and injuries resulting from handling, disease, and insects.
- E. Plants approved at pre-planting inspection are subject to rejection during planting if found to be defective.
- F. Rejected plants shall be identified as such in an obvious manner, shall be removed from the Site, and be replaced with acceptable plants.

**1.06 CLEAN-UP**

- A. Upon completion of all planting operations, the portion of the Site used for a work or storage area by the Contractor shall be cleaned of all debris, superfluous materials, and equipment. All such materials and equipment shall be entirely removed from the Site.
- B. All walks or pavement shall be swept or washed clean upon completion of the Work of this Section.
- C. During the entire Contract period, plant containers that have been cut or removed from plant materials shall be removed from the Site daily.

**1.07 MAINTENANCE OF LANDSCAPING PLANTING PRIOR TO ACCEPTANCE OF PROJECT**

- A. General: The Contractor shall be responsible for protecting, watering, and maintaining all planting and irrigation systems until final acceptance of all Work under the Contract.
- B. At time of acceptance of the complete project, the lawn shall be totally established with no bare spots, have been mowed a minimum of 4 times, and the grass shall be at least 1-1/4 to 2 inches in height.
- C. Watering: Trees and shrubs shall be thoroughly soaked after planting and provided with additional water at intervals as necessary to provide for good health and growth of the planting.
- D. Upon completion of lawn seeding, the entire area shall be soaked to saturation by a fine spray. The new planting shall be kept watered by the



sprinkling system existing on the Site during dry weather or whenever necessary for proper establishment of the lawn. Care shall be taken to avoid excessive washing or puddling on the surface and any such damage caused thereby shall be repaired.

- E. Protection: The Contractor shall provide adequate protection to all newly seeded areas, including the installation of approved temporary fences to prevent trespassing and damage, as well as erosion control, until the end of the correction of defects period.
- F. The Contractor shall replace any materials or equipment or which its employees or Subcontractors have damaged.
- G. Partial utilization of the project shall not relieve the Contractor of any of the requirements contained in the Contract Documents.
- H. Mowing of Lawn Areas: First mowing of lawn areas shall begin as soon as the grass has reached a height of 3 inches and subsequent mowing shall be at least once a week, or as often as necessary to maintain all lawn areas at a uniform height of 1-1/2 to 2 inches.
- I. All lawns shall be fertilized every 3 weeks with 6 lb of 16-16-8 commercial fertilizer per 1000 sq ft for the first 7 weeks and be fertilized thereafter once each 5 months prior to acceptance.
- J. Plants shall be maintained in a vigorous, thriving condition by watering, cultivating, weeding, pruning, spraying, and other operations necessary. No trees or shrubs will be accepted unless they are healthy and show satisfactory foliage conditions.
- K. All planted areas shall be cultivated at least every 2 weeks and be raked smooth to present a neat appearance, and additional mulch shall be added where necessary.
- L. Maintenance shall include, in addition to the foregoing, cleaning, edging, repairs to stakes, wire, and wrappings, the repair of erosion, and all other necessary work of maintenance. Sidewalks and other paved areas shall be kept clean while planting and maintenance are in progress.
- M. Any existing sprinkler lines broken or disrupted shall be replaced to proper working order prior to work under this Contract Dnd shall be acceptable to the City.

#### **1.08 FINAL INSPECTION AND GUARANTEE**

- A. Inspection of lawns and planting will be part of final inspection under the Contract.

- B. Written notice requesting inspection shall be submitted to the Engineer at least 10 days prior to the anticipated inspection date.
- C. Final acceptance prior to start of the guarantee period of the Contract will be on written approval by the Engineer, on the satisfactory completion of all Work, including maintenance, but exclusive of the replacement of plant material.
- D. Any delay in the completion of any item of work in the planting operation that extends the planting into more than one season shall extend the correction period in accordance with the date of completion given above.
- E. The Contractor shall replace, as soon as weather conditions permit, all dead plants and all plants not in a vigorous, thriving condition, which are noted at the end of the one-year correction period.
- F. Plants used for replacement shall be of the same size and variety as existing plants. Replacement plants shall be furnished, planted, staked, and mulched as indicated for new plants.
- G. All Work under this Section shall be left in good order to the satisfaction of the City and the Engineer, and the Contractor shall, without additional expense to the City, replace any trees, shrubs, etc., which develop defects or die during the one-year correction period.

#### **1.09 MAINTENANCE FOLLOWING ACCEPTANCE OF PROJECT**

- A. Begin maintenance of plantings immediately after each area is planted and continue for the periods required to establish acceptable vegetation, but no less than the following:
  - 1. Seeded lawns: at least 60 days, after date of substantial completion. If seeded in fall and not given full 60 days of maintenance, or if not considered acceptable at that time, continue maintenance during following spring until acceptable lawn is established.
  - 2. Sodded lawns: at least 30 days after date of substantial completion.
  - 3. Trees and shrubs: at least 60 days after date of substantial completion.
- B. Maintain lawns by watering, fertilizing, weeding, mowing, trimming and other operations such as rolling, re-grading, replanting as required to establish a smooth, acceptable lawn, free of eroded or bare areas.

- C. Re-mulch with new mulch in areas where mulch has been disturbed by wind or maintenance operations sufficiently to nullify its purpose. Anchor as required to prevent displacement.
- D. Replant bare areas with same materials specified for lawns.
- E. Watering: Provide and maintain temporary piping, hoses, and watering equipment to convey water from sources and to keep planted areas uniformly moist as required for proper growth.
- F. Lay out temporary watering system and arrange watering schedule to prevent puddling, water erosion, and displacement of seed or mulch (if any). Lay out temporary watering system to avoid necessity of walking over muddy or newly seeded areas.
- G. Mow lawns as soon as there is enough top growth to cut with mower set at specified height for principal species planted. Repeat mowing as required to maintain specified height. Remove no more than 40 percent of grass leaf growth in initial or subsequent mowings. Do not delay mowing until grass blades bend over and become matted. Do not mow when grass is wet. Time initial and subsequent mowings to maintain following grass height:  
  
Mow grass from 1-1/2 inches to 2 inches high. Do not mow to less than 1-1/2 inches.
- H. Apply second fertilizer application after first mowing and when grass is dry. Use fertilizer that will provide at least 1.0 lb. of actual nitrogen per 1,000 sq. ft. of lawn area.

## **PART 2 – PRODUCTS**

### **2.01 GENERAL**

- A. All landscaping materials for soil conditioning, weed abatement, or planting shall be first-grade, commercial quality and shall have certificates indicating the source of material, analysis, quantity, or weight attached to each sack or container or furnished with each delivery. Delivery certificates shall be given to the Engineer as each shipment of material is delivered. A list of the materials used, together with typical certificates of each material, shall be submitted to the Engineer prior to final acceptance.

## 2.02 TOPSOIL

- A. Topsoil shall be obtained from naturally drained areas and shall be fertile, friable loam suitable for plant growth. Topsoil shall be subject to inspection and approval at the source of supply and upon delivery.
- B. The topsoil shall be of uniform quality, free from subsoil, stiff or lumpy clay, hard clods, hardpan, rocks, disintegrated debris, plants, roots, seeds, and any other materials that would be toxic or harmful to plant growth. Topsoil shall contain no noxious weeds or noxious weed seeds.
- C. The topsoil shall contain at least 6 percent organic matter as determined by loss of weight after ignition of moisture-free samples in accordance with current methods of the Association of Official Agricultural Chemists.
- D. The acidity of the topsoil shall result in soil pH between 5.5 and 7.5. The salinity level shall be less than 3 millimhos/cm.
- E. Clay, as determined by the Bouyoucous hydrometer or by the decantation method, shall not exceed 60 percent of the topsoil material.
- F. Mechanical analysis shall be performed and shall conform to ASTM D 422.
- G. Soil mix for interior plants shall be sphagnum moss or a soil mix furnished in bags or other standard containers with name, weight, and guaranteed analysis of contents clearly marked thereon. The soil mix shall be a mix designed specifically for interior container or potted planting.

## 2.03 FERTILIZER AND ADDITIVES

- A. Fertilizer shall be furnished in bags or other standard containers with name, weight, and guaranteed analysis of contents clearly marked thereon.
- B. Chemical fertilizers shall be a mixed commercial fertilizer conforming to FS O-F-241D, Type I, with percentages of nitrogen, phosphoric acid, and potash at 5-10-5 or 6-10-4. Fertilizers shall be uniform in composition, dry, and free flowing.
- C. Animal fertilizer shall be well-rotted cattle manure, free from sawdust, shaving, or refuse of any kind, and shall contain not more than 25 percent straw by volume.
- D. Tablets shall be 12 grams each 20-10-5 "**Agriform**," "**Lesslie**," or equal.

- E. Lime shall be dolomitic limestone containing not less than 85 percent of total carbonates. Limestone shall be ground to such fineness that 100 percent will pass a No. 200 sieve.
- F. Agricultural gypsum shall be standard brand agricultural calcium sulfate intended for soil application and shall contain 19 percent combined sulfur.

#### **2.04 PEAT MOSS**

- A. Peat shall be a domestic product conforming to FS Q-P-166E and may be reed peat, sedge peat, moss peat, reed muck, or sedge muck. Moss shall be of horticultural grade (fine shreds).
- B. Sphagnum peat moss shall be good quality baled peatmoss free from injurious materials.

#### **2.05 MULCH**

- A. Mulching material shall be well-rotted sawdust a minimum of 2 years old, pine bark or tan bark, all free of sticks, stones, clay, or other foreign materials. Bark mulch shall be medium chunk size, fortified with 1 percent nitrogen. [Mulch shall consist of 1/3 cattle manure and 2/3 coarse granular sawdust. Mulch shall be composted at least 90 days with added nitrogen and shall be free of weed seed and roots, sticks, lumps, and other foreign matter].
- B. "Silva-fiber" mulch material shall be equal to "Silva-fiber" as manufactured by the Weyerhaeuser Company, Silva Products Department, Tacoma, Washington.
- C. Wood chip mulch in planting beds shall be clean, inexpensive, pulverized shavings, 2-inch minimum to 4-inch maximum length as produced by chipping tree branches or similar means, placed to a depth of 4 inches.
- D. Straw mulch or native hay for a soil/seed stabilizer shall be clean hay or straw applied at a rate of 3 tons per acre. Mulch is to be crimped into soil with a mulch crimper. Spacing on the blades of the mulch crimper shall be 6 inches minimum and 9 inches maximum. Blades shall be sufficiently weighted to penetrate the ground 3 inches.

#### **2.06 PLANT MATERIALS**

- A. Plants shall meet requirements of the Contract Documents and shall be in accordance with the botanical names and applicable standards of quality, size, condition, and type. Plants shall be true to name, genera, species, and variety in accordance with reference publications.

- B. Plant names are defined in "Standardized Plant Names" and "Bailey's Encyclopedia of Horticulture." When a name is not found in either reference, the accepted name used in the nursery trade shall apply.
- C. Plants shall be marked for identification. Each bundle of plants and at least 25 percent of each species and variety of separate plants in any one shipment shall have legible labels securely attached before delivery to the Site.
- D. Trees and shrubs shall be measured while their branches are in their normal position. Height and spread dimensions refer to the main body of the plant and not from branch or root tip to tip. No trees will be accepted with leaders cut or so damaged that cutting is necessary.
- E. All plants shall be symmetrical and shall conform to the size, age, and condition on the Plant List. Exceptions are as follows:
  - 1. Plants larger than indicated on the plant list may be used if approved by the Engineer, but approval of such plants shall not increase the Contract Price. If the use of larger plants is approved, the spread of roots or ball earth shall be increased in proportion to the size of the plant. Bare root plants furnished in size greater than indicated shall be balled and burlapped when required by the Engineer.
  - 2. Where caliper or other dimensions of any plant materials are omitted from the Plant List, it shall be understood that such plant materials shall be normal stock for type listed.
- F. Plants shall be of sound health, vigorous, and free from plant disease and shall be well-branched, shall have full foliage when in leaf, and shall have a healthy well-developed normal root system. Cold storage plants will not be accepted. Plants that are sensitive to shock from elevation change shall be grown for at least 2 years at elevations close enough to the Site to alleviate any plant damage due to such change.
- G. Bare rooted (BR) plants shall have well-developed branch systems and vigorous root systems. They shall be dug to sufficient depth to insure full recovery and development of the plants. Roots of these plants shall be covered with a uniformly thick coating of mud puddled immediately after they are dug.
- H. Balled and burlapped (BB) plants shall have firm, natural balls of earth of diameter not less than that indicated and be of sufficient depth to include all the fibrous and feeding roots. No plant moved with a ball will be

accepted if the ball is cracked or broken before or during plant operations, except on approval of the Engineer.

- I. Roots or balls of all plants shall be adequately protected at all times from sun and drying winds.
- J. Plants indicated to be in marked cans, pots, or other containers on the Plant List shall have been grown in the containers for a minimum of 6 months and a maximum of 2 years. Roots shall fill the containers but show no evidence of being or having been root bound.
- K. Trees shall have straight trunks and all old abrasions and cuts shall be completely callused over. In no case shall trees be topped before delivery.
- L. Plants shall have been transplanted or root-pruned at least once in the 2 years prior to delivery, but plants shall not be pruned immediately prior to delivery except as authorized by the Engineer.

## **2.07 SEED MIXTURES**

- A. Seed shall conform to applicable City, county, state, and federal regulations. Seed shall be mixed by dealer. The Contractor shall furnish dealer's guaranteed germination figure for each variety
- B. Grass seed shall be fresh, clean, new-crop seed, composed of the following varieties mixed in the proportions by weight. Purity and germination percentage shall be the results of testing.

<u>Common Names</u>	<u>Proportion by Weight (percent)</u>	<u>Purity (percent)</u>	<u>Germination (percent)</u>
<b>Type 1:</b>			
Baron Kentucky Blue Grass	100	90	90
<b>Type 2</b>			
Buffalo Grass	33	90	90
Creeping Red Fescue	25	90	90
Fuccinellia	25	90	90
Penn Fine Rye Grass	17	90	90
<b>Type 3:</b>			
Western Wheat Grass	33	90	90
Fairway Crested Wheat Grass	33	90	90
Buffalo Grass	34	90	90

**2.08 SOD GRASS**

- A. Sod shall contain at least 85 percent permanent grass suitable to the climate in which it is to be placed; shall not contain more than 25 percent nursing grass; shall not contain more than 10 percent weed and undesirable grasses, and shall be of good texture, free from obnoxious roots, stones, and foreign materials. The sod shall be cut in 16-inch squares, 16-inch wide strips, 4-ft wide strips, or 4-ft wide squares, uniformly 1-1/2 inches thick with clean cut edges.
- B. The sod shall be nursery grown Kentucky Bluegrass sod. It shall be uniformly cut approximately 3/4-inch or more thick and shall be well rooted, 2-year old growth of permanent and desirable grasses indigenous to this general location. The sod shall be practically free from weeds and undesirable grasses.

**2.09 WOOD EDGING**

- A. Wood edging shall be 2-inch x 4-inch redwood construction heart stock.

**2.10 STAKING MATERIALS**

- A. Stakes for supporting trees shall be sound No. 2 redwood of uniform size not less than 2-inch x 2-inch or 2-1/2-inch min diameter wood posts of lengths on the staking details. All knots shall be solid. Alternatively,



stakes may be galvanized iron pipe, 1-inch (ID) diameter with 2 coats of olive green flat enamel paint

- B. Hose for covering wire shall be new or used black or green 2-ply fiber-bearing garden hose, not less than 1/2-inch inside diameter.
- C. Wire for tree bracing and guying shall be double strand pliable No. 10-gage galvanized steel wire or vinyl-coated steel wire.
- D. Tree ties of other materials may be used with prior approval of Engineer.

## **2.11 MISCELLANEOUS MATERIALS**

- A. Wrapping material for trees, 2-inch diameter or larger, shall be 2 thicknesses of crinkled paper cemented together with bituminous material in strips 4-inch wide. Twine for tying shall be medium or coarse sisal yarn with a light impregnation of oil condensate from asphalt or tar.
- B. Soil mix for interior plants shall be sphagnum moss or an approved soil mix furnished in bags or other standard containers with name, weight, and guaranteed analysis of contents clearly marked thereon. The soil mix shall be a mix designed specifically for interior container or potted planting.

## **PART 3 – EXECUTION**

### **3.01 GENERAL**

- A. The landscape work shall not be performed at any time when it may be subject to damage by climatic conditions.
- B. Dimensions and plant locations shall be coordinated with Engineer and final location shall be Site-oriented by the planter and Engineer. Any discrepancies or inconsistencies shall be brought to the attention of the Engineer.
- C. Delivery of materials may begin only after samples and tests have been approved by the Engineer. Materials provided shall be not less quality than the approved sample.
- D. The Contractor shall provide temporary fencing, barricades, covering, or other protections to preserve existing landscaping items indicated to remain and to protect the adjacent properties and other structures when they may be damaged by the landscape work.

- E. The Contractor shall retain the services of a tree surgeon approved by the Engineer to repair damage to existing trees. Existing trees, which are to be saved, and which cannot be restored to full growth, as determined by tree surgeon, shall be removed and replaced with a new similar tree of 24-inch box size, unless otherwise approved by the Engineer.
- F. The Contractor shall remove and/or relocate landscape items such as trees, shrubs, grass, other vegetation, improvements, and obstructions as indicated.
- G. Waste materials shall be removed and disposed of off the Site, unless otherwise indicated.
- H. It shall be the responsibility of the Contractor to obtain information regarding utilities in the area of work and to prevent damage to the same. The Contractor shall protect the utilities as necessary.
- I. Burning of combustible materials on the Site shall not be permitted.
- J. The Contractor shall protect structures, sidewalks, pavements, and other facilities that are subject to damage during landscape work. Open excavations shall be provided with barricades and warning lights which conform to the requirements of governing authorities and the state's OSHA safety requirements from dusk to dawn each day and when needed for safety.
- K. Planting areas include all areas to be landscaped, unless indicated otherwise.

### **3.02 SOIL PREPARATION**

- A. The landscape work shall not begin until all other trades have repaired all areas of settlement, erosion, rutting, etc., and the soils have been re-established, re-compacted, and refinished to finish grades. The Engineer shall be notified of all areas that prevent the landscape work from being executed.
- B. Areas requiring grading by the landscaper, including adjacent transition areas, shall be uniformly level or sloping between finish elevations to within 0.10-ft above or below required finish elevations.
- C. The landscape work shall not proceed until after walks, curbs, pavings, edging, and irrigation systems are in place. Work under the Contract shall be completed to a point where the landscape areas will not be disturbed. The subgrade shall be free of waste materials of all kinds.

- D. During grading, waste materials in the planting areas, such as weeds, rocks 2 inches and larger, building materials, rubble, wires, cans, glass, lumber, sticks, etc., shall be removed from the Site. Weeds shall be dug out by the roots.
- E. Fertilizers, additives, seed, peat, etc., subject to moisture damage shall be kept dry in a weatherproof storage place.
- F. After removal of waste materials, the planting area subgrade shall be scarified and pulverized to a depth of not less than 6 inches, and all surface irregularities below the cover of topsoil shall be removed.
- G. Finish grading shall consist of:
  - 1. Final contouring of the planting areas
  - 2. Placing 4 inches of topsoil over all areas to be planted, unless indicated otherwise
  - 3. Placing all soil additives and fertilizers
  - 4. Tilling of planting areas
  - 5. After tilling, bringing areas to uniform grades by floating and/or hand raking
  - 6. Making minor adjustment of finish grades as directed by the Engineer
  - 7. Removing waste materials such as stones, roots, or other undesirable foreign material and raking, disking, dragging, and smoothing soil ready for planting
- H. Any unusual subsoil condition that will require special treatment shall be reported to the Engineer.
- I. Topsoil shall be uniformly distributed over all areas where required. Subgrade and topsoil shall be damp and free from frost.
- J. Surface drainage shall be provided as indicated by shaping the surfaces to facilitate the natural run-off of water. Low spots and pockets shall be filled with topsoil and graded to drain properly.
- K. Finish grade of all planting areas shall be 1½ inches below finish grade of adjacent pavement of any kind.

- L. In all shrub planting areas, 1½ inches of peat moss or soil-aid shall be raked into the top 3 inches of soil.

### **3.03 DELIVERY, STORAGE, AND HANDLING OF PLANT MATERIALS**

- A. No plants other than the required samples shall be dug or delivered to the Site until the required inspections have been made and the plant samples are approved.
- B. Plants shall not be pruned prior to delivery except upon approval by the Engineer.
- C. Plant material shall be planted on the day of delivery if possible. The Contractor shall protect the stock in a temporary nursery at the Site where it shall be protected from sun and drying winds and shall be shaded, kept moist, and protected with damp soil, moss, or other acceptable material. Plants shall be planted within 2 days after delivery.
- D. All balled and burlapped plants which cannot be planted immediately after delivery shall be set on the ground and be well protected with soil, wet moss, or other acceptable material. Bare rooted plants, which cannot be planted immediately, shall be planted in heeled-in trenches immediately upon delivery. No material heeled-in for more than one week may be used. Bundles of plants shall be opened and the plants separated before the roots are covered. Care shall be taken to prevent air pockets among the roots.
- E. During planting operations, bare roots shall be covered with canvas, wet straw, or other suitable materials. No plants shall be bound with wire or rope at any time so as to damage the bark or break branches.
- F. Plants shall not be picked up or moved by stem or branches, but shall be lifted and handled from the sides of the containers.
- G. Plants shall be lifted and handled from the bottom of the ball or container. Plants with balls cracked or broken before or during planting operations will not be accepted and shall be immediately removed from the Site.

### **3.04 TREE AND PLANT LOCATIONS**

- A. The Contractor shall locate and stake all tree and shrub locations and have the locations approved by the Engineer before starting excavation for same. The plant locations shall be observed, and their locations shall be adjusted as directed by Engineer before final approval.

- B. No trees shall be located closer than 72 inches to structures unless otherwise indicated. Ground covers and shrubs may be planted up to structures or curbs.

### **3.05 PLANT PITS**

- A. Plant pits, centered on location stakes, shall be excavated circular pits with vertical sides and flat or saucer shape bottom in accordance with the following sizes, unless indicated otherwise:
  - 1. Tree pits shall be at least 2 feet greater in diameter than the specific diameter of ball or spread of roots, and at least 6 inches below depth of ball or roots. A 3-inch layer of manure shall be worked thoroughly to a depth of 6 inches below the pit bottom.
  - 2. Shrubs shall be planted in pits or holes of soil 24 inches deep below finished grade, or deep enough to properly set the plant at finished grade with a minimum of 6 inches of planting soil under balls of all plants. Shrubs with balls shall be planted in pits that are at least 24 inches greater in diameter than the bottom of ball. Bare root shrubs shall be planted in pits at least 12 inches below the roots of the plant.

### **3.06 PREPARED BACKFILL**

- A. Tree and shrub pit backfilling soil shall consist of 3 parts topsoil, and 1 part peat or soil-aid by volume. Commercial fertilizer shall be sparingly mixed with the prepared topsoil, using 5 lb/cu yd or as required by manufacturer's printed recommendations.
- B. Materials shall be thoroughly rotary-mixed on the Site before placement. Mixing of materials in pits, bins, trenches or beds will not be permitted.
- C. Tree and shrub pits shall be provided with fertilizer tablets as follows:
  - 1. 1 per one-gallon can plant
  - 2. 3 per 5-gallon can plant
  - 3. 5 per 15-gallon can plant

### **3.07 ROCKS OR UNDERGROUND OBSTRUCTIONS**

- A. In the event that rock or underground obstructions are encountered in the excavation of plant pits, alternative locations will be selected by the

Engineer. Moving of trees to alternative locations shall not entail additional costs to the City.

### **3.08 SETTING PLANT MATERIALS**

- A. The soil shall not be worked when the moisture content is so great that excessive compaction will occur, or when it is so dry that a dust will form in the air or clods will not break readily. Water shall be applied if necessary to provide ideal moisture for filling and for planting.
- B. Plants shall be set plumb and straight in center of pits, and at such a level that after settlement that the crown of the plant will be 2 inches above the finished grade.
- C. Balled and burlapped trees shall have planting soil placed and compacted around base of ball to fill all voids. All burlap ropes or wires shall be removed from the sides and tops of balls.
- D. Roots of bare root plants shall be properly spread out and planting soil carefully worked in among them. All broken or frayed roots shall be cut off clean.
- E. Vines shall be removed from stakes, untied, and securely fastened in an approved manner to wall or fence next to which they are planted.
- F. Ground cover plants shall be evenly spaced, staggered in rows, and set at intervals indicated, so as to produce a uniform effect. Plants shall be watered immediately after planting operations have been completed.
- G. Shrubs and vines shall be pruned to remove damaged branches. All bare root shrubs shall be pruned and shaped to compensate for transplant root loss.
- H. Planting soil around roots or balls shall be thoroughly compacted and watered. After planting, the soil in the shrub beds shall be cultivated between shrubs, raked smooth, and neatly outlined. Muddy soil shall not be used for backfilling. All broken or frayed roots shall be properly cut off.
- I. Trees and shrubs on slopes steeper than 6 to 1 shall be provided with watering dams or berms at least 6 inches high and 8 inches wider than planting pit unless indicated otherwise.
- J. Trees shall be thoroughly watered immediately after planting.
- K. Remove all tags and labels when directed by Engineer.

- L. Trees shall have trunks wrapped in acceptable tree wrap material from base up to and above at least the second scaffold branch.

### **3.09 STAKING**

- A. Staking of trees shall be done immediately after planting. Plants shall stand plumb after staking. Staking shall be as indicated.
- B. No balled and burlapped specimen "tree-like" shrubs shall be staked.
- C. Trees of 2-inch caliper and larger shall be guyed at points of branching with 3 wires spaced equally around and outside the perimeter of the ball. Guy wires shall be covered with rubber hose at the bark, protected by approved material at points of contact. Each guy shall be positioned below crotches and fastened to a 4-inch diameter by 18-inch wood deadman, 12 inches below grade. One turnbuckle shall be provided for each guy.
- D. Trees less than 2-inch caliper shall be supported by 2 stakes placed diametrically opposite at perimeter line of ball and to sufficient depth to hold tree rigid. Stakes shall be driven vertically and not twisted or pulled. Trees shall be wired to each stake as indicated on staking details. Trees shall be protected with rubber hose over wires at points of contact. Evergreen trees shall be guyed.

### **3.10 PRUNING AND MULCHING**

- A. Each tree and shrub shall be pruned in accordance with standard horticultural practice to preserve the natural character of the plant in the manner fitting its use in the landscape design, as approved by the Engineer.
- B. All dead wood or suckers and all broken or badly bruised branches shall be removed by thinning out and shortening branches. Deciduous bare-rooted plants shall have not less than 1/3 of their respective leaf surfaces removed. All cuts shall be made just above a healthy bud. Pruning shall be done with clean, sharp tools.
- C. Cuts over 3/4-inch diameter shall be painted with approved tree paint. Paint shall cover all exposed cambium as well as other living tissue. Paint shall be waterproof, adhesive, and elastic antiseptic; shall be free from kerosene, coal tar, creosote, or other materials injurious to the life of the tree; and shall be approved before it is used.
- D. Plants shall be mulched after planting and cultivating have been completed. A layer of mulch materials shall be spread on finished

landscaping grade within all planting areas to a depth of 2 inches. The mulch around isolated plants shall be 6 inches greater in diameter than the planting hole. All shrub and ground cover beds shall be completely covered with the mulch.

- E. All deciduous tree trunks shall be thoroughly sprayed with a methoxychlor or similar insecticide, and wrapped immediately after planting, with wrapping material overlapping 1-1/2 inches, wound from ground line to the second branch, and securely taped in at least 5 places, including the top, middle, and bottom.

### **3.11 SODDING**

- A. Grass sod shall be provided where indicated and shall be maintained.
- B. The soil shall be prepared and fertilized before sodding. The Contractor shall prepare only enough ground that can be planted within 24 hours thereafter.
- C. Soil preparation shall consist of the following:
  - 1. Preparation of sub-grade grading shall be per the paragraphs titled "General" and "Soil Preparation" above.
  - 2. Finish grading shall be per the paragraph entitled "Soil Preparation," above. Topsoil required at areas to be sodded shall be 1-1/2 inches. The soil additives and fertilizer for finish grading shall consist of mulch at 5 cu yd/1000 sq ft and commercial fertilizer at 20 lb/1000 sq ft.
- D. Sod shall be cut and laid on Site the same day.
- E. The sod shall be placed over leveled, compacted, and prepared finish graded soil. The topsoil and sub-base shall be moist enough to resist shifting.
- F. Sod may be placed at any time when the ground is not frozen. The surface on which the sod is to be laid should be firm and free from footprints or other depressions. A string or line of boards may be used as a guide for setting the first line of sod across the area. Sods of the next course shall be matched against the edge of this first line in such a way the joints between the individual sod pieces in the 2 courses do not coincide. Successive courses shall be matched against the last line laid, in the same manner.



- G. Sod joints shall be closely laid and filled with a mixture of grass seed and screened topsoil at the rate of 2 lbs of seed to each cu yd of topsoil. Sod fill soil shall be thoroughly tamped to a true and even surface at the required finished grade.
- H. Sod on slopes should be staked down by driving a wooden peg through the sod. Wire stakes shall not be used for pegging sod.
- I. Sod shall always be laid across slopes.
- J. All new sod shall be rolled or firmly but lightly tamped with a suitable wooden or metal tamper, sufficiently to set or press sod into underlying soil.
- K. After sodding has been completed, the sodded area shall be cleaned up and thoroughly moistened by sprinklers.

### **3.12 SEEDING-GENERAL**

- A. Grass seeds shall be provided where lawn is indicated and shall be maintained.
- B. The soil shall be prepared and fertilized before seeding or shall be prepared per hydro-seeding instructions. The Contractor shall prepare only enough ground that can be planted within 24 hours thereafter.
- C. Soil preparation shall consist of the following:
  - 1. Preparation of sub-grade grading shall be per paragraphs titled "General" and "Soil Preparation," respectively, above.
  - 2. Finish grading of soil per paragraph entitled "Soil Preparation," above. The soil additives and fertilizer for finish grading shall consist of mulch at 5 cu yd/1000 sq. ft. and commercial fertilizer at 20 lb/1000 sq. ft.
- D. Sow seed at the rate of 2 lbs to 1000 sq ft of area. Equal quantities of seed shall be sown in the directions at right angles to each other to produce an even distribution of seed over the entire area.
- E. No seeding shall be done when wind velocity exceeds 4 mph, within 24 hours after rain, or if the surface has been compacted without first loosening the ground.
- F. The seed shall then be covered with a fine layer of soil to a depth not greater than 1/4-inch.

- G. All lawn areas shall be covered with sphagnum peat moss or clean straw uniformly at a rate of 1-1/2 standard bales per 1000 sq ft.
- H. After covering the seeds with soil and peat or straw, the planted area shall be rolled in 2 directions with a 200-lb roller or other roller designed for lawn seeding.
- I. All lawn slopes greater than 5 percent or places where erosion is a problem shall be mulched with straw at a rate of 2 bales per 1000 sq ft.
- J. Mechanical application (hydroseeding) is acceptable. The Contractor shall notify the Engineer of proposed method, mulch, and type of equipment to be used and shall receive approval before beginning this operation.

### **3.13 HYDRO-SEEDING**

- A. One-step hydro-seeding may be utilized. This method consists of preparing the seed bed; combining seed mixture at the rate of 6 lb per 1000 sq ft for Lawn Mix; fertilizer at the rate of 15 lb per 1000 sq ft; "Silva-fiber" or equal at the rate of 1400 lb per acre of area and water in tanks; agitating these compounds into a well-mixed slurry suspension; and spraying the mixture under pressure onto the prepared areas to be seeded.
- B. Two-step hydro-seeding may be utilized. This method consists of preparing the seed bed; sowing seed mixture at the rate of 6 lb per 1000 sq ft for Lawn Mix in two directions with an approved mechanical seeder; incorporating fertilizers; and spraying under pressure a mixture of water and "Silva-fiber" or equal at the rate of 1400 lb per acre onto prepared, seeded, and fertilized areas. Fertilizer can be applied with the water and "Silva-fiber" or equal mixture if desired.

### **3.14 MISCELLANEOUS ITEMS**

- A. After all steel edging, plants, and sprinkler emitters are in place, and the existing sod in all wood mulch, cobble, and gravel areas has been removed to a depth of 4 inches, place filter fabric over the entire area to receive wood mulch, cobble, or gravel.
- B. Wood chip mulch shall be placed in all shrub areas where indicated, spread carefully and evenly to a minimum depth of 4 inches, or to match existing, over planted areas.

- C. Gravel shall be placed in the planting areas as indicated, spread carefully and evenly to a minimum depth of 4 inches, or to match existing, over the entire area.
- D. Cobble shall be hand placed where indicated. Care shall be taken to fill all spaces, placing small cobble in the voids between the large cobble. When complete, Contractor shall fill all voids with sand and water thoroughly to ensure solid settlement of sand into all cracks and voids. Repeat as necessary to secure cobble from shifting.
- E. Boulders shall be placed in field as directed by Engineer.

END OF SECTION

[This page intentionally left blank]

---

**SECTION 02910**

**TREES, PLANTS AND GROUND COVERS**

**PART 1 GENERAL**

**1.01 SCOPE**

- A. The Contractor shall furnish and plant trees, plants and ground covers as shown on the Drawings and as specified herein.
- B. Under this section, the Contractor shall also replace trees, plants and ground covers damaged by his operations. Existing trees, plants and ground covers damaged by the Contractor's operations shall be replaced as directed by the Engineer, to the satisfaction of the Engineer and at no additional cost to the Owner.
- C. Work under this Section shall include, but not be limited to:
  - 1. Soil preparation.
  - 2. Planting mixes.
  - 3. Mulch and planting accessories.
  - 4. Furnishing and installing trees, plants and ground covers.
  - 5. Existing tree care.
  - 6. Filling around trees to remain.
  - 7. Maintenance.

**1.02 QUALITY ASSURANCE**

- A. Comply with requirements of Section 02000, Site Work
- B. Plant names shall comply with "Standardized Plant Names" as adopted by the latest edition of the American Joint Committee of Horticultural Nomenclature. Names of varieties shall conform generally with names accepted by the nursery trade. Provide stock true to botanical name and legibly tagged.
- C. Comply with sizing and grading standards of the latest edition of "American Standard for Nursery Stock". A plant shall be dimensioned as it stands in its

natural position.

- D. All plants shall be nursery grown under climatic conditions similar to those in the locality of the project.
- E. Stock furnished shall be at least the minimum size as stock to be replaced. Larger stock is acceptable, at no additional cost, and providing that the larger plants will not be cut back to the existing plant size.
- F. Provide "specimen" plants with height, shape and character of growth. Tag specimen trees or shrubs at the source of supply. The Engineer will inspect specimen selections at the source of supply for suitability and adaptability to selected location. When specimen plants cannot be purchased locally, provide sufficient photographs of the proposed specimen plants for approval.
- G. Plants may be inspected and approved at the place of growth, for compliance with specification requirements for quality, size, and variety. Such approval shall not impair the right of inspection and rejection upon delivery at the site or during the progress of the work.
- H. Contractor shall provide and pay for material testing. Testing agency shall be acceptable to the Engineer. Provide the following data:
  - 1. Test representative material samples proposed for use.
  - 2. Topsoil:
    - a. pH factor.
    - b. Mechanical analysis.
    - c. Percentage of organic content.
    - d. Recommendations on type and quantity of additives required to establish satisfactory pH factor and supply of nutrients to bring nutrients to satisfactory level for planting.
  - 3. Peat Moss:
    - a. Loss of weight by ignition.
    - b. Moisture absorption capacity.

### **1.03 SUBMITTALS**

- A. Submittals shall be made in accordance with the requirements of the General Conditions of the Contract Documents. In addition, the following specific information shall be provided:
  - 1. Mulch samples.

2. Planting accessories samples.
3. Certification for topsoil source and pH value; peat moss and plant fertilizer.
4. Material test reports.
5. Upon plant material acceptance, submit written instructions recommending procedures for maintenance of plant materials.

#### **1.04 DELIVERY, STORAGE AND HANDLING**

- A. Deliver fertilizer materials in original, unopened, and undamaged containers showing weight, analysis, and name of manufacturer. Store materials in a manner to prevent wetting and deterioration.
- B. Take all precautions customary in good trade practice in preparing plants for moving. Workmanship that fails to meet the highest standards will be rejected. Spray deciduous plants in foliage with an approved "Anti-Desiccant" immediately after digging to prevent dehydration. Dig, pack, transport, and handle plants with care to ensure protection against injury. Inspection certificates required by law shall accompany each shipment invoice or order to stock and on arrival, the certificate shall be submitted to the Engineer.
- C. Protect all plants from drying out. If plants cannot be planted immediately upon delivery, properly protect them with soil, wet peat moss, or in a manner acceptable to the Engineer. Water heeled-in plantings daily. No plant shall be bound with rope or wire in a manner that could damage or break the branches.
- D. Cover plants transported on open vehicles with a protective covering to prevent wind burn.
- E. Provide dry, loose topsoil for planting bed mixes. Frozen or muddy topsoil is not acceptable.

#### **1.05 PROJECT CONDITIONS**

- A. Notify Engineer at least 7 working days prior to installation of plant material.
- B. Protect existing utilities, paving, and other facilities from damage caused by landscaping operations.
- C. Locate and protect existing irrigation system(s) during planting operations. Repair irrigation system components, damaged during planting operations, at Contractor's expense.

## 1.06 WARRANTY

- A. Warrant plant material to remain alive and be in healthy condition for a period of 1 year after planting and acceptance. Inspection of plants will be made by the Engineer at completion of planting.
- B. Replace, in accordance with these specifications, all plants that are dead or, as determined by the Engineer, are in an unhealthy or unsightly condition, and have lost their natural shape due to dead branches, or other causes due to the Contractor's negligence. The cost of such replacement is at Contractor's expense. Warrant all replacement plants for 1 year after installation.
- C. Warranty shall not include damage or loss of trees, plants, or ground covers caused by fires, floods, freezing rains, lightning storms, or winds over 75 miles per hour, winter kill caused by extreme cold and severe winter conditions not typical of planting area; acts of vandalism or negligence on the part of the Owner.
- D. Remove and immediately replace all plants, as determined by the Engineer to be unsatisfactory during the initial planting installation.

## PART 2 PRODUCTS

### 2.01 MATERIALS

- A. Plants: Provide plants typical of their species or variety; with normal, densely-developed branches and vigorous, fibrous root systems. Provide only sound, healthy, vigorous plants free from defects, disfiguring knots, sunscald injuries, frost cracks, abrasions of the bark, plant diseases, insect eggs, borers, and all forms of infestation. All plants shall have a fully developed form without voids and open spaces. Plants held in storage will be rejected if they show signs of growth during storage.
  - 1. Dig balled and burlapped plants with firm, natural balls of earth of sufficient diameter and depth to encompass the fibrous and feeding root system necessary for full recovery of the plant. Provide ball sizes complying with the latest edition of the "American Standard for Nursery Stock". Cracked or mushroomed balls are not acceptable.
  - 2. Container-grown stock: Grown in a container for sufficient length of time for the root system to have developed to hold its soil together, firm and whole.
    - a. No plants shall be loose in the container.



- b. Container stock shall not be pot bound.
3. Provide new tree species to match existing tree species. New species shall be provided with a single main trunk. Trees that have the main trunk forming a "Y" shape are not acceptable.
4. Plants planted in rows shall be matched in form.
5. Plants larger than those existing may be used when acceptable to the Engineer. If the use of larger plants is acceptable, increase the spread of roots or root ball in proportion to the size of the plant.
6. No pruning wounds shall be present with a diameter of more than 1-inch and such wounds must show vigorous bark on all edges.
7. Shrubs and small plants shall meet the requirements for spread as follows:
  - a. The measurements for height shall be taken from the ground level to the height of the top of the plant and not the longest branch.
  - b. Single stemmed or thin plants will not be accepted.
  - c. Side branches shall be generous, well-twigged, and the plant as a whole well-bushy to the ground.
  - d. Plants shall be in a moist, vigorous condition, free from dead wood, bruises, or other root or branch injuries.

## 2.02 ACCESSORIES

- A. Topsoil for Planting Beds and Tree Pits: Fertile, friable, natural topsoil of loamy character, without admixture of subsoil material, obtained from a well-drained arable site, reasonably free from clay, lumps, coarse sands, stones, plants, roots, sticks, and other foreign materials, with acidity range of between pH 6.0 and 6.8.
  1. Topsoil that has been stripped and stockpiled on site shall be the topsoil to be utilized on this project. Provide additional topsoil if necessary.
  2. Provide topsoil free of substances harmful to the plants which will be grown in the soil. Provide 12-inches of topsoil in all plant beds and tree pits.
  3. Planting mixture shall be composed of four (4) parts topsoil, two (2) parts peat moss, one (1) part sand and one (1) part well rotted manure, mixed together thoroughly, and worked into existing soil.

- B. Peat Moss: Brown to black in color, weed and seed free granulated raw peat or baled peat, containing not more than 9% mineral on a dry basis. Provide ASTM D2607 sphagnum peat moss with a pH below 6.0 for ericaceous plants.
- C. Fertilizer:
  - 1. Plant Fertilizer Type "A": Commercial type approved by the Engineer, containing 5% nitrogen, 10% phosphoric acid, and 5% potash by weight. 1/4 of nitrogen in the form of nitrates, 1/4 in form of ammonia salt, and 1/2 in form of organic nitrogen.
  - 2. Plant Fertilizer Type "B": Approved acid-base fertilizer.
- D. Anti-Desiccant: Protective film emulsion providing a protective film over plant surfaces; permeable to permit transpiration. Mixed and applied in accordance with manufacturer's instructions.
- E. Premium grade shredded pine bark 3/4-inch to 1-1/2-inch diameter. Furnish in 3 cubic feet bags or bulk.
- F. Water: Free of substances harmful to plant growth. Hoses or other methods of transportation shall be furnished by the Contractor.
- G. Stakes for Staking: Hardwood, 2-inch x 2-inch x 8-feet long.
- H. Stakes for Guying: Hardwood, 2-inch x 2-inch x 36-inches long.
- I. Guying/Staking/Wire: No. 10 or 12, gage galvanized wire.
  - 1. For large trees (4-inch caliper and greater) use turnbuckles and heavier gage wire as indicated below
    - a. Stakes for Staking: Hardwood, 4-inches x 4-inches x 8-feet long.
    - b. Guying/Staking/Wire: No. 6 or 8 gage galvanized wire.
  - 2. Turnbuckles: Galvanized steel of size and gage required to provide tensile strength equal to that of the wire. Turnbuckle openings shall be at least 3-inches.
- J. Staking and Guying Hose: Two ply, reinforced garden hose not less than 1/2-inch inside diameter.
- K. Tree Wrap: Standard waterproofed tree wrapping paper, 2-1/2-inches wide, made of 2 layers of crepe kraft paper weighing not less than 30 lbs. per

ream, cemented together with asphalt. Tree wrap shall be removed at 12 months after installation of plant material.

- L. Twine: Two-ply jute material.
- M. Soil Separator: Rot resistant polypropylene filter fabric, water permeable, and unaffected by freezing and thawing.
- N. Drainage Tile: ASTM F405 corrugated polyethylene drainage tubing, perforated.
- O. Drainage Fill: AASHTO M43 #6 (3/8-inch to 3/4-inch) clean uniformly graded stone or gravel.

## **PART 3 EXECUTION**

### **3.01 INSPECTION**

- A. Examine proposed planting areas and conditions of installation. Do not start planting work until unsatisfactory conditions are corrected.

### **3.02 CARE OF TREES TO REMAIN**

- A. Minor fills of 6-inches or less: Fill with topsoil; hand grade to required finish grade elevation.
- B. Moderate fills of 12-inches or less: Place layer of 3/4-inch to 1-1/2-inch stone or gravel on grade. Provide aggregate depth 1/2 of fill height, minimum of 3-inches. Cover drainage fill with polypropylene filter fabric or 1" thickness straw choke. Fill remaining depth with loose topsoil; hand grade to required finish grade elevations.
- C. Deep fills over 12-inches: Place layer of 3/4-inch to 1-1/2-inch stone or gravel on grade. Extend drainage fill to within 2-inch of required finish grade. Cover drainage fill with polypropylene filter fabric or 1-inch thickness straw choke. Fill remaining depth with loose topsoil; hand grade to required finish grade elevation. Provide tile drainage system and vents as indicated.
- D. Deep fills over 18-inches: Place 4-inch depth of 1-inch to 2-inches stone or gravel fill on grade, extending three (3) feet beyond the outer branch drip line around tree branch perimeter. Cover drainage fill with polypropylene filter fabric or 1-inch thickness straw choke. Place 1-inch to 2-inches stone or gravel fill around tree trunk, extending to within 2-inches of required finish grade elevation. Fill remaining depth with loose topsoil; hand grade to required finish grade elevation. Do not place earth fill in contact with tree trunk, maintain 18-inches diameter of drainage fill exposed at finish grade.

### 3.03 PREPARATION

- A. Time of Planting:
  - 1. Evergreen material: Plant evergreen materials between September 1 and November 1 or in spring before new growth begins. If project requirements require planting at other times, plants shall be sprayed with anti-desiccant prior to planting operations.
  - 2. Deciduous material: Plant deciduous materials in a dormant condition. If deciduous trees are planted in-leaf, they shall be sprayed with an anti-desiccant prior to planting operation.
  - 3. Planting times other than those indicated shall be acceptable to the Engineer.
- B. Planting shall be performed only by experienced workmen familiar with planting procedures under the supervision of a qualified supervisor.
- C. Locate plants as indicated or as approved in the field after staking by the Contractor. If obstructions are encountered that are not shown on the drawings, do not proceed with planting operations until alternate plant locations have been selected.
- D. Excavate circular plant pits with vertical sides, except for plants specifically indicated to be planted in beds. Provide shrub pits at least 12-inches greater than the diameter of the root system and 24-inches greater for trees. Depth of pit shall accommodate the root system. Provide undisturbed tamped down topsoil to hold root ball at nursery grade as shown on the drawings. Remove excavated materials from the site.
- E. Provide pre-mixed planting mixture for use around the balls and roots of the plants consisting of planting topsoil and 1/2 lb. plant fertilizer Type "A" for each cu. yd. of mixture.
- F. Provide pre-mixed ground cover bed planting mixture consisting of 3 parts planting topsoil to 1 part peat moss and 1/2 lb. plant fertilizer Type "A" per cu. yd. Provide beds a minimum of 12-inches deep. If slopes are greater than 4 to 1 increase depth to 18-inches.
- G. Provide pre-mixed planting mixture for use around the balls and roots of ericaceous plants consisting of 2 part planting topsoil to 1 part sphagnum peat moss and 1/2 lb. plant fertilizer Type "B" per cu. yd. of mixture.

### 3.04 INSTALLATION

- A. Set plant material in the planting pit to proper grade and alignment. Set plants upright, plumb, and faced to give the best appearance or relationship to each other or adjacent structure. Set plant material 2-inches to 3-inches above the finish grade. No filling will be permitted around trunks or stems. Backfill the pit with planting mixture. Do not use frozen or muddy mixtures for backfilling. Form a ring of soil around the edge of each planting pit to retain water.
- B. After balled and burlapped plants are set, muddle planting soil mixture around bases of balls and fill all voids. Remove all burlap, ropes, and wires from the tops of balls of trees and remove entirely from all other plant material.
- C. Space ground cover plants in accordance with indicated dimensions. Adjust spacing as necessary to evenly fill planting bed with indicated quantity of plants. Plant to within 12-inches of the trunks of trees and shrubs within planting bed and to within 6-inches of edge of bed.
- D. Drain tile: The Contractor shall provide drainage tiles if he encounters standing water in planting pits or conditions warrant. Install drainage tile with perforations down and closed joints, firmly bedded in minimum 4-inch layer of granular fill material. Provide full bearing for each pipe section. Provide continuous slope in the direction of flow.
  - 1. Provide collars and couplings for all in-line joints and elbows for all corners and changes in direction.
  - 2. Provide unperforated run out pipe. Extend drainage tile to out fall indicated and make connection.
  - 3. Obtain required inspections and perform testing before backfilling. Remove obstructions, replace damaged components, and retest system as required. Provide a satisfactory free flowing drainage tile system.
  - 4. Place drainage fill over drain piping after satisfactory testing and acceptance. Compact drainage fill layers not exceeding 6" in loose depth. Exercise care to avoid damage or displacement of installed piping.
    - a. Completely cover drain lines to width of at least 6-inches each side of pipe and above top of pipe to within 18-inches of finish grade.
    - b. Provide soil separator over drainage fill prior to topsoil fill. Overlap a minimum of 6-inches.
  - 5. Install topsoil fill over compacted drainage fill. Compact topsoil fill in

layers not exceeding 6-inches in loose depth. Extend topsoil fill to indicated finish or existing grade elevations.

E. Mulching:

1. Mulch tree and shrub planting pits and shrub beds with required mulching material 3-inches deep immediately after planting. Thoroughly water mulched areas. After watering, rake mulch to provide a uniform finished surface.
2. Mulch ground cover beds with mulch 2-inches deep immediately after planting.

F. Wrapping, Guying and Staking:

1. Inspect trees for injury to trunks, evidence of insect infestation, and improper pruning before wrapping.
2. Wrap trunks of all trees spirally from bottom to top with specified tree wrap and secure in place.
  - a. Overlap 1/2 the width of the tree wrap strip and cover the trunk from the ground to the height of the second branch.
  - b. Secure tree wrap in place with twine wound spirally downward in opposite direction, tied around the tree in at least 3 places in addition to the top and bottom. Wrapping and twine to be removed 12 months after installation of plant material.
3. Staking/Guying:
  - a. Stake/guy all trees immediately after lawn seeding or sodding operations and prior to acceptance. When high winds or other conditions which may affect tree survival or appearance occur, the Engineer may require immediate staking/guying.
  - b. Stake deciduous trees under 3-inches in caliper. Stake evergreen trees under 8-feet tall.
  - c. Guy deciduous trees over 3-inches in caliper. Guy evergreen trees over 8-feet tall.
4. All work shall be acceptable to the Engineer.

G. Pruning:

1. Prune branches of deciduous stock, after planting, to balance the loss of roots and preserve the natural character appropriate to the particular

plant requirements. In general, remove 1/4 to 1/3 of the leaf bearing buds, proportion shall in all cases be acceptable to the Engineer. Remove or cut back broken, damaged, and unsymmetrical growth of new wood.

2. Multiple leader plants: Preserve the leader which will best promote the symmetry of the plant. Cut branches flush with the trunk or main branch, at a point beyond a lateral shoot or bud at a distance of not less than 1/2 the diameter of the supporting branch. Make cut on an angle.
3. Prune evergreens only to remove broken or damaged branches.

H. Care of Existing Trees:

1. Selectively prune existing trees in designated areas, under Engineer's direction. Remove sucker shoots, dead, rubbing, and damaged branching.
2. Fertilize designated existing trees with 2 to 3 lbs. of Type "A" plant fertilizer per inch of trunk diameter, for trees less than 6-inches in diameter and 3 to 5 lbs. for trees greater than 6-inches in diameter.
  - a. Fertilize in early spring before growth begins or in late October.
  - b. Fertilize at 2-feet to 3-feet on center in a triangular pattern to a depth of 18-inches within the dripline.
  - c. Injection or drilling fertilization methods, when used, shall be acceptable subject to Engineer's approval.
3. Water existing trees every 2 weeks until acceptance. Water thoroughly with a fine mist sprinkler head soaker hose or hose at a low flow rate over the entire drip line area as required to allow water to penetrate to a depth of 12-inches to 18-inches.

I. Tree Relocation:

1. Transplant trees designated for relocation to locations shown on the drawings. Prune, dig, ball and burlap, move and plant in accordance with specified tree planting requirements.

### 3.05 MAINTENANCE

- A. Maintain plantings until completion and acceptance of the entire project.
- B. Maintenance shall include pruning, cultivating, weeding, watering, and application of appropriate insecticides and fungicides necessary to maintain plants free of insects and disease.

1. Re-set settled plants to proper grade and position. Restore planting saucer and adjacent material and remove dead material.
2. Tighten and repair guy wires and stakes as required.
3. Remove tree wrapping and twine 12 months after installation of plant material.
4. Correct defective work as soon as possible after deficiencies become apparent and weather and season permit.
5. Water trees, plants, and ground cover beds within the first 24 hours of initial planting, and not less than twice per week until final acceptance.

### **3.06 ACCEPTANCE**

- A. Inspection to determine acceptance of planted areas will be made by the Engineer, upon Contractor's request. Provide notification at least 10 working days before requested inspection date. Planted areas will be accepted provided all requirements, including maintenance, have been complied with and plant materials are alive and in a healthy, vigorous condition.
- B. Upon acceptance, the Owner will assume plant maintenance.

### **3.07 CLEANING**

- A. Perform cleaning during installation of the work and upon completion of the work. Remove from site all excess materials, soils, debris, and equipment. Repair damage resulting from planting operations.

**+ + + END OF SECTION 02910 + + +**



---

**SECTION 02920**

**Site Restoration**

**PART 1 GENERAL**

**1. 1.01 SCOPE**

- A. The Contractor shall provide all, labor, materials, equipment and incidentals required for all site restoration and related operations necessary shown on the Drawings or specified in these Specifications.
- B. This section includes disposition of materials and structures encountered in the Work, all cleanup and any other similar, incidental, or appurtenant operations which may be necessary to properly complete the Work.

**1.02 SUBMITTALS**

- A. Submittals shall be made in accordance with the requirements of the General Conditions of the Contract Documents. In addition, the following specific information shall be provided:
  - 1. The Contractor shall submit certificates of inspection as required by government authorities. The Contractor shall submit other data substantiating that materials comply with specified requirements.
  - 2. The Contractor shall submit instructions recommending procedures to be established by the City for maintenance of site restoration work for one (1) full year.

**1.03 QUALITY ASSURANCE**

- A. The Contractor shall ship site restoration materials with certificates of inspection required by authorities having jurisdiction. The Contractor shall comply with regulations applicable to site restoration materials.
- B. If specified site restoration materials are not obtainable, the Contractor shall submit proof of non-availability to the Engineer together with proposal for use of equivalent material.

**1.04 SAFETY REQUIREMENTS**

- A. Hazards Control:
  - 1. The Contractor shall store volatile wastes in covered metal containers, and

remove from the site of the Work daily.

2. The Contractor shall prevent accumulation of wastes that create hazardous conditions.
  3. The Contractor shall provide adequate ventilation during use of volatile or noxious substances.
- B. The Contractor shall conduct cleaning and disposal operations in compliance with local ordinances and environmental laws and regulations.
1. The Contractor shall not burn or bury rubbish and waste materials on the site of the Work without prior written permission from the Engineer.
  2. The Contractor shall not dispose of volatile wastes such as mineral spirits, oil, or fuel in open drainage ditches or storm or sanitary drains.

#### **1.05 DELIVERY**

- A. The Contractor shall deliver packaged materials in containers showing weight, analysis, and name of manufacturer. The Contractor shall protect materials from deterioration during delivery and while stored at the site of the Work.

#### **PART 2 PRODUCTS**

**(NOT USED)**

#### **PART 3 EXECUTION**

##### **3.01 DISPOSITION OF MATERIALS AND STRUCTURES ENCOUNTERED IN THE WORK**

- A. Existing materials or structures that may be encountered (within the lines, grades, or trenching sections established for completion of the Work), if unsuitable or unacceptable to the Engineer for use in the Work, and for which the disposition is not otherwise specified, shall either be disposed of by the Contractor or shall remain the property of the City as further provided in this section.
- B. At the option of the City, any existing materials or structures of "value" encountered in the Work shall remain the property of the City. The term "value" shall be defined by the City.
- C. Any existing materials or structures encountered in the Work, and determined not to be of "value" by the City, shall be disposed of by the Contractor, in an approved manner.

### **3.02 JOB CONDITIONS**

- A. The Contractor shall determine the locations of underground utilities and perform Work in a manner which will avoid possible damage. The Contractor shall hand excavate, as required. The Contractor shall maintain grade stakes set by others until removal is mutually agreed upon by parties concerned.
- B. All bare earth areas within the limit of work shall be grassed, mulched, or covered with other plant material as shown on the Drawings.
- C. On a continuous basis, the Contractor shall maintain the site of the Work free from accumulations of waste, debris, and rubbish caused by his operations.
- D. At completion of the Work, the Contractor shall remove waste materials, rubbish, tools, equipment, machinery, and surplus materials, and clean all sight-exposed surfaces. The Contractor shall leave the site of the Work clean and ready for occupancy or use.
- E. The Contractor shall proceed with the complete site restoration work as rapidly as portions of the site of the Work become available, working within seasonal limitations for each kind of site restoration work required. The Contractor will not be allowed to postpone cleanup and seeding or sodding until the end of the Work.
- F. When conditions detrimental to plant growth are encountered, such as rubble fill, adverse drainage conditions, or obstructions, the Contractor shall notify the Engineer before planting.
- G. The Contractor shall install materials during normal planting seasons for each type of site restoration work.
- H. The Contractor shall plant or replace trees and shrubs after final grades are established and prior to planting of lawns, unless otherwise acceptable to the Engineer. If planting of trees and shrubs occurs after lawn work, the Contractor shall protect lawn areas and promptly repair damage to lawns resulting from planting operations. Refer to Section 02900, Trees, Plants and Ground Covers.
- I. The Contractor may, at his option, employ additional measures (other than those specified) to prevent loss of, or damage to the Work resulting from the effects of wind and/or water. No additional compensation will be made for the employment of such additional measures.

### **3.03 CLEANUP**

- A. During site restoration work, the Contractor shall keep pavements clean and the site of the Work in an orderly condition.

- B. The Contractor shall protect site restoration work and materials from damage due to site restoration operations, operations by other contractors, and trades and trespassers. The Contractor shall maintain protection during installation and maintenance periods. The Contractor shall treat, repair, or replace damaged site restoration work as directed by the Engineer.
- C. Immediately upon completion of any section of the Work and before payment therefore has been made, the Contractor shall remove from the site of the Work all construction equipment, temporary structures, and debris, and shall restore the site of the Work to a condition equal to or better than that which existed prior to construction. Waste materials shall be disposed of at locations satisfactory to the City or affected regulatory agencies.
- D. The Contractor shall not remove barricades and warning and direction signs until directed by the Engineer.
- E. After completion of all Work required by the Contract and before final payment has been made, the Contractor shall make a final cleanup of each separate part of the Work; shall restore all surfaces to a neat and orderly condition; and shall remove all construction equipment, tools, and supplies.

#### **3.04 INSPECTION AND ACCEPTANCE**

- A. When site restoration work is completed, including maintenance, the Engineer will, upon request, make an inspection to determine acceptability.
- B. Where inspected site restoration work does not comply with the requirements of the Engineer, the Contractor shall replace rejected work and continue specified maintenance until reinspected by the Engineer and found to be acceptable. The Contractor shall remove rejected plants and materials promptly from the site of the Work.

**+ + + END OF SECTION 02920 + + +**

**SECTION 02933  
SEEDING AND SODDING**

**PART 1 GENERAL**

**1.01 SCOPE**

- A. The work covered by this Section consists of furnishing all labor, equipment and material required to place topsoil, seed, commercial fertilizer, agricultural limestone and mulch material, including seedbed preparation, harrowing, compacting and other placement operations on graded earthen areas as described herein and/or shown on the Drawings.
- B. Seeding operations shall be conducted on all newly graded earthen areas not covered by structures, pavement or sidewalks; all cleared or grubbed areas which are to remain as finish grade surfaces; and on all existing turf areas which are disturbed by construction operations and which are to remain as finish grade surfaces. Areas disturbed by borrow activities shall also be seeded according to these Specifications.
- C. The Work shall also include temporary seeding operations to stabilize earthen surfaces during construction or inclement weather and to minimize stream siltation and erosion. Temporary seeding shall be performed at the times and locations as directed by the Engineer.

**1.02 SUBMITTALS**

- A. Submittals shall be made in accordance with the requirements of the General Conditions of the Contract Documents. In addition, the following information shall be submitted:
  - 1. Prior to seeding operations, labels or certified laboratory reports from an accredited commercial seed laboratory or a state seed laboratory showing the analysis and germination of the seed to be furnished. Acceptance of the seed test reports shall not relieve the Contractor of any responsibility or liability for furnishing seed meeting the requirements of this Section.
  - 2. Prior to topsoil operations, the Contractor shall obtain representative samples and furnish soil test certificates including textural, pH, and organic ignition analysis from the State University Agricultural Extension Services or other certified testing laboratory.

**PART 2 PRODUCTS**

**2.01 ACCEPTABLE MANUFACTURERS**

- A. Wood cellulose fiber mulch shall be manufactured by Weyerhaeuser Company or Conway Corporation.

## **2.02 MATERIALS AND CONSTRUCTION**

### **A. Topsoil**

1. Utilizing designated stockpiles or borrow areas on site, the Contractor shall place a minimum of 6-inches of topsoil over all graded earthen areas and over any other areas to be seeded. Sources of topsoil shall be approved by the Engineer prior to disturbance.
2. Topsoil shall be a friable loam containing a large amount of humus and shall be original surface soil of good, rich, uniform quality, free from any material such as hard clods, stiff clay, hardpan, partially disintegrated stone, pebbles larger than 1/2-inch in diameter, lime, cement, bricks, ashes, cinders, slag, concrete, bitumen or its residue, boards, sticks, chips or other undesirable material harmful or unnecessary to plant growth. Topsoil shall be reasonably free from perennial weeds and shall not contain objectionable plant material, toxic amounts of either acid or alkaline elements or vegetable debris undesirable or harmful to plant life.
3. Topsoil shall be natural topsoil without admixture of subsoil material, and shall be classifiable as loam, silt loam, clay loam, sandy loam or a combination thereof. The pH shall range from 5.5 to 7.0. Topsoil shall contain not less than 5 percent nor more than 20 percent, by weight, of organic matter as determined by loss on ignition of oven dried samples to 65 Degrees C.

### **B. Seed**

1. Seed shall be hulled common Bermuda (Cynodon Dactylon) guaranteed by the dealer to be 98% minimum purity and 90% minimum germination and certified free of giant strain Bermuda.
2. Seed shall be delivered in new bags or bags that are sound and labeled in accordance with the U.S. Department of Agriculture Federal Seed Act.
3. All seed shall be from the last crop available at time of purchase and shall not be moldy, wet or otherwise damaged in transit or storage.
4. Seed shall bear the growers analysis testing to 98 percent for purity and 90 percent for germination. At the discretion of the Engineer, samples of seed may be taken for check against the grower's analysis.
5. Species, rate of seeding, fertilization and other requirements are shown in

Table 02933-1 at the end of this Section.

C. Fertilizer and Liming Materials

1. Fertilizer and liming materials shall comply with applicable state, local and federal laws concerned with their production and use.
2. Commercial fertilizer shall be a ready mixed material and shall be equivalent to the grade or grades specified in Table 02933-1. Container bags shall have the name and address of the manufacturer, the brand name, net weight and chemical composition.
3. Agricultural limestone shall be a pulverized limestone having a calcium carbonate content of not less than 85 percent by weight.
4. Fertilizer shall be a complete fertilizer, the content of which shall meet the following minimum requirements: 10% nitrogen, 10% phosphoric acid, 10% potash, available materials. Fertilizer shall be uniform in composition, dry and free flowing, and shall be delivered to the site in original unopened containers bearing the manufacturer's statement of guarantee.
5. Ammonium Nitrate shall be a standard brand and shall be delivered to the site in original unopened containers. It shall contain not less than 33-1/3% Nitrogen.

D. Mulch Material

1. All mulch materials shall be air dried and reasonably free of noxious weeds and weed seeds or other materials detrimental to plant growth.
2. Mulch shall be composed of wood cellulose fiber, straw or stalks, as specified herein. Mulch shall be suitable for spreading with standard mulch blowing equipment.
3. Straw mulch shall be partially decomposed stalks of wheat, rye, oats or other approved grain crops.
4. Stalks shall be the partially decomposed, shredded residue of corn, cane, sorghum or other approved standing field crops.

E. Mulch Binder

1. Mulch on slopes exceeding 3 to 1 ratio shall be held in place by the use of an approved mulch binder. The mulch binder shall be non-toxic to plant life and shall be acceptable to the Engineer.
2. Emulsified asphalt binder shall be Grade SS-1, ASTM D977. Cutback

asphalt binder shall be Grade RC 70 or RC 250.

- F. Inoculants for Legumes: All leguminous seed shall be inoculated prior to seeding with a standard culture of nitrogen fixing bacteria that is adapted to the particular seed involved.
- G. Water: Water shall be clean, clear water free from any objectionable or harmful chemical qualities or organisms and shall be furnished by the Contractor.
- H. Sod
  - 1. Sod shall be living, growing sod of Bermuda hybrids "Tifway 419" or Tifgreen 328". This includes sod which is dormant during the cold or dry season and capable of renewing growth after the dormant period. All sod shall be obtained from approved sources. The presence of weeds or other noxious growth or any other foreign material which may be detrimental to the proposed planting will be cause of rejection. At least 85% of the plants in the sod shall be composed of the designated variety of Bermuda grass.
  - 2. The Engineer shall be notified of sources before it is harvested. Approval of such sources shall not be construed as an acceptance of the material. The sod will be subject to inspection while it is being planted and any material which has been permitted to dry out excessively or exposed to extreme heat, or which is not viable, will be rejected.
  - 3. In the harvesting of the sod, grass more than 3-inches tall shall be mowed to a height of 3-inches, raked and removed before sod cutting begins. The sod shall be cut into square or rectangular sections which may vary in length, but which shall be of uniform width and thickness, and shall have at least ½-inch of soil adhering firmly to the roots. Care shall be exercised at all times to retain the soil on the roots of the sod during the process of cutting, transporting and planting. Sod shall be transplanted within 24 hours from the time it is harvested. All sod stored shall be kept moist, shall be protected from exposure to the air and sun and from freezing, and shall not be stored for more than 10 days. Sod shall be cut and moved only when the soil moisture conditions are such that favorable results can be expected.

## **PART 3 EXECUTION**

### **3.01 SECURING AND PLACING TOPSOIL**

- A. Topsoil shall be secured from areas from which topsoil has not been previously removed, either by erosion or mechanical methods. Topsoil shall not be removed to a depth in excess of the depth approved by the Engineer.



- B. The area or areas from which topsoil is secured shall possess such uniformity of soil depth, color, texture, drainage and other characteristics as to offer assurance that, when removed the product will be homogeneous in nature and will conform to the requirements of these Specifications.
- C. All areas from which topsoil is to be secured, shall be cleaned of all sticks, boards, stones, lime, cement, ashes, cinders, slag, concrete, bitumen or its residue and any other refuse which will hinder or prevent growth.
- D. In securing topsoil from a designated pit, or elsewhere, should strata or seams of material occur which do not come under the requirements for topsoil, such material shall be removed from the topsoil or if required by the Engineer, the pit shall be abandoned.
- E. Before placing or depositing topsoil upon any areas, all improvement within the area shall be completed, unless otherwise approved by the Engineer.
- F. The areas in which topsoil is to be placed or incorporated shall be prepared before securing topsoil for use.

### **3.02 SEEDBED PREPARATION**

- A. Before liming, fertilizing and seeding, the topsoil surfaces shall be trimmed and worked to true line from unsightly variation, bumps, ridges and depressions and all detrimental material, roots and stones larger than 3-inches in any dimension shall be removed from the soil.
- B. Not earlier than 24 hours before the seed is to be sown, the soil surface to be seeded shall be thoroughly cultivated to a depth of not less than 2-inches with a weighted disc, tiller, pulvimixer or other equipment, until the surface is smooth and in a condition acceptable to the Engineer.
- C. If the prepared surface becomes eroded as a result of rain or for any other reason, or becomes crusted before the seed is sown, the surface shall again be cultivated for seeding.
- D. Ground preparation operations shall be performed only when the ground is in a tillable and workable condition, as determined by the Engineer.

### **3.03 FERTILIZATION AND LIMING**

- A. Following seedbed preparation, fertilizer shall be applied to all areas to be seeded so as to achieve the application rates shown in Table 02933-1 at the end of this Section.

- B. Fertilizer shall be spread evenly over the seedbed and shall be lightly harrowed, raked, or otherwise incorporated into the soil for a depth of 1/2-inch.
- C. Fertilizer need not be incorporated in the soil as specified above when mixed with seed in water and applied with power sprayer equipment. The seed shall not remain in water containing fertilizer for more than 30 minutes when a hydraulic seeder is used.
- D. Agricultural limestone shall be thoroughly mixed into the soil according to the rates in Table 02933-1. The specified rate of application of limestone may be reduced by the Engineer if pH tests indicate this to be desirable. It is the responsibility of the Contractor to obtain such tests and submit the results to the Engineer for adjustment in rates.
- E. It is the responsibility of the Contractor to make one application of a maintenance fertilizer according to the recommendations listed in Table 02933-1.
- F. On the approved grade, spread 20 lbs. per 1,000 sq. ft. of 10-10-10 fertilizer into top 3-inches, hand rake and smooth. The surface shall be brought to finish grade requirements, allowance being made for settlement. Finish grades shall be smooth and free from hollows or other inequalities.
- G. Three weeks after construction of lawns add ammonium nitrate at the rate of 5 lbs. per 1000 sq. ft. of lawn area, and thoroughly water in.

### **3.04 SEEDING**

- A. Seed of the specified group shall be sown as soon as preparation of the seedbed has been completed. No seed shall be sown during high winds, nor until the surface is suitable for working and is in a proper condition. Seeding shall be performed during the dates shown in Table 02933-1 unless otherwise approved by the Engineer. Seed mixtures may be sown together provided they are kept in a thoroughly mixed condition during the seeding operation.
- B. Seed shall be uniformly sown by any approved mechanical method suitable for the slope and size of the areas to be seeded, preferably with a broadcast type seeder, windmill hand seeder or approved mechanical power drawn seed drills. Hydro-seeding and hydro-mulching may be used on steep embankments, provided full coverage is obtained. Care shall be taken to adjust the seeder for seedings at the proper rate before seeding operations are started and to maintain their adjustment during seeding. Seed in hoppers shall be agitated to prevent segregation of the various seeds in a seeding mixture.
- C. Immediately after sowing, the seeds shall be covered and compacted to a depth of 1/8 to 3/8-inch by a cultipacker or suitable roller.

- D. Leguminous seeds shall be inoculated prior to seeding with an approved and compatible nitrogen-fixing inoculant in accordance with the manufacturer's mixing instructions.
- E. Italian rye grass (*Lolium Multiflorum*) shall be evenly seeded with a mechanical spreader at the rate of 5 lbs. per 1000 sq. ft. of area, lightly rake, suitably compact and thoroughly water. Before planting the permanent lawn, the rye shall be thoroughly scarified in a manner to incorporate it into the top three inches of the ground.
- F. The planting of bermuda grass shall be done only within the season extending from April 15 to August 1.

### 3.05 MULCHING

- A. All seeded areas shall be uniformly mulched in a continuous blanket immediately after seeding. The mulch shall be applied so as to permit some sunlight to penetrate and the air to circulate and at the same time shade the ground, reduce erosion and conserve soil moisture. Approximately 25 percent of the ground shall be visible through the mulch blanket.
- B. One of the following mulches shall be spread evenly over the seeded areas at the following application rates:

Wood Cellulose Fiber	1,400 pounds/acre
Straw	4,000 pounds/acre
Stalks	4,000 pounds/acre

- C. These rates may be adjusted at the discretion of the Engineer at no additional cost to the Owner, depending on the texture and condition of the mulch material and the characteristics of the seeded area.
- D. The Contractor shall cover structures, poles, fence and appurtenances if the mulch binder is applied in such a way that it would come in contact with or discolor the structures.
- E. Mulch and binder shall be applied by suitable blowing equipment at closely controlled application rates in a manner acceptable to the Engineer.

### 3.06 WATERING

- A. The Contractor shall be responsible for maintaining the proper moisture

content of the soil to insure adequate plant growth until a satisfactory stand is obtained. If necessary, watering shall be performed to maintain adequate water content in the soil.

- B. Watering shall be accomplished by hoses, tank truck or sprinklers in such a way to prevent erosion, excessive runoff and overwatered spots.

### **3.07 MAINTENANCE**

- A. Upon completion of seeding operations, the Contractor shall clear the area of all equipment, debris and excess material and the premises shall be left in a neat and orderly condition.
- B. The Contractor shall maintain all seeded areas without additional payment until final acceptance of the work by the Owner, and any regrading, refertilizing, reliming, reseeding or remulching shall be done at Contractor's own expense. Seeding work shall be repeated on defective areas until a satisfactory uniform stand is accomplished. Damage resulting from erosion, gulleys, washouts or other causes shall be repaired by filling with topsoil, compacting and repeating the seeding work at Contractor's expense.
- C. Contractor's guarantee of one (1) year shall also cover a fully rooted stand of grass.

**TABLE 02933-1**  
**SEEDING REQUIREMENTS**

Area	Sowing Season	Species	Seed	Rates per 1,000 Square Feet		
				Fertilizer	Limestone	Maintenance**
Flat to rolling terrain with slopes less than 3:1	3/1 to 4/15	Rebel II Turf-Type Tall Fescue	6-8 lbs.	30 lbs. 6-12-12	200 lbs.	10 lbs. 10-10-10
	9/1 to 11/15	Rebel II Turf-Type Tall Fescue	6-8 lbs.	30 lbs. 6-12-12	200 lbs.	15 lbs. 10-10-10
Embankments with slopes greater than 3:1	3/1 to 6/1	Crownvetch* Kentucky 31 Fescue Weeping Lovegrass	1 lb. 2 lbs. 1/4 lb.	30 lbs. 6-12-12	200 lbs.	10 lbs. 0-20-20
	8/1 to 11/1	Crownvetch* Kentucky 31 Fescue Annual Ryegrass	1 lb. 2 lb. 2 lb.	30 lbs. 6-12-12	200 lbs.	10 lbs. 0-20-20

\* Requires inoculation

\*\* Maintenance fertilizer shall be applied in early spring following initial establishment of cover

**+++ END OF SECTION 02933 +++**

---

**SECTION 03300**

**Concrete Work**

**PART 1 – GENERAL**

**1.01 SCOPE**

- A. The extent of concrete work is shown on the Drawings and indicated in the Specifications.

**1.02 QUALITY ASSURANCE**

- A. Codes and Standards: Comply with the provisions of the following codes, specifications and standards, except as otherwise shown or specified:
1. ACI 301 "Specifications for Structural Concrete for Buildings"
  2. ACI 311.4R "Guide for Concrete Inspection"
  3. ACI 318 "Building Code Requirements for Reinforced Concrete"
  4. ACI 347 "Recommended Practice for Concrete Formwork"
  5. ACI 304 "Recommended Practice for Measuring, Mixing, Transporting and Placing Concrete"
  6. Concrete Reinforcing Steel Institute, "Manual of Standard Practice"
  7. Where local building code requirements exist, comply with provisions of such codes that are more stringent than the preceding codes and standards.
- B. Workmanship: The Contractor is responsible for correction of concrete work that does not conform to the specified requirements, including strength, tolerances and finishes. Correct deficient concrete as approved by the Engineer.
- C. Construction Tolerances:
1. Variation from Plumb: For lines and surfaces of columns, piers, walls, and arises, do not exceed 1/4 inch in 10 feet nor more than one inch total; except for exposed corners, control joints and other conspicuous lines, do not exceed 1/4 inch in any story or 20 foot maximum, nor 1/2 inch in 40 feet or more.

2. Variation from Grade: For grades shown for slab soffits, ceilings, beam soffits, and in arises, do not exceed 1/4 inch in 10 feet, 3/8 inch in any bay or 20 foot maximum, nor 3/4 inch in 40 feet or more. For exposed lintels, sills, parapets, joints and other conspicuous lines, do not exceed 1/4 inch in any bay or 20 foot maximum, or 1/2 inch in 40 feet or more from horizontal or grade indicated.
3. Variation from Linear Building Line: For position shown in plan and related position of columns, walls, and partitions, do not exceed 1/2 inch in any bay or 20 foot maximum, nor one inch in 40 feet or more.
4. Variation in Cross-Sectional Dimensions: For columns and beams and thickness of slabs and walls, do not exceed minus 1/4 inch nor plus 1/2 inch.

### 1.03 CLASSES OF CONCRETE

- A. Class "A" concrete 4,000 psi compressive strength at 28 days shall be steel reinforced and includes the following:
  1. Foundations
  2. Walls
  3. Slab on grade
  4. Beams
  5. Elevated concrete floors
  6. Columns
- B. Class "B" concrete 3,000 psi compressive strength at 28 days shall be placed without forms or with simple forms, with little or no reinforcing, and includes the following:
  1. Sidewalks
  2. Curbs
  3. Pavement patch
  4. Thrust blocking
  5. Fence post footing
  6. Mud slabs
  7. Fill concrete
  8. Concrete encasement of pipe

**1.04 FACTORY TESTING AND MIX DESIGN**

- A. Testing Before Construction: Employ concrete testing laboratory, acceptable to Engineer, at Contractor's expense to perform material evaluation tests and to design concrete mixes.
- D. Tests for Concrete Materials:
1. Test aggregates by the methods of sampling and testing of ASTM C 33.
  2. For Portland cement, sample the cement and determine the properties by the methods of test of ASTM C 150.
  3. Certificates of material properties and compliance with specified requirements may be submitted in lieu of testing, when acceptable to the Engineer.
- C. Proportioning and Design of Mixes:
1. Submit written mix design to the Engineer for review and approval at least 15 days prior to start of work. Do not begin concrete work until the mix design has been approved by the Engineer.
  2. Prepare design mixes for each type of concrete. Use an independent testing facility acceptable to the Engineer for preparing and reporting proposed mix designs.
  3. Proportion mixes by either laboratory trial batch or field experience methods, using materials to be employed on the project for each class of concrete required, complying with ACI 211.1.
  4. Submit written reports to the Engineer of each proposed mix for each class of concrete at least 15 days prior to start of work. Do not begin concrete production until mixes have been reviewed by the Engineer.
- D. Laboratory Trial Batches:
1. When laboratory trial batches are used to select concrete proportions, prepare test specimens in accordance with ASTM C 192 and conduct strength tests in accordance with ASTM C 39, as specified in ACI 301.
  2. Establish a curve showing relationship between water-cement ratio (or cement content) and compressive strength with at least three



points representing batches that produce strengths above and below that required. Use not less than three specimens tested at 28-days, or an earlier age when acceptable to the Engineer, to establish each point on the curve.

E. Field Experience Method:

1. When field experience methods are used to select concrete proportions, establish proportions as specified in ACI 301.
2. Strength data for establishing standard deviation will be considered suitable if the concrete production facility has certified records consisting of at least thirty consecutive tests in one group or the statistical average for two groups totaling thirty or more tests, representing similar materials and projects conditions.

F. Standard Deviation:

1. If standard deviation exceeds 600 psi or if no suitable records are available, select proportions to produce an average strength of at least 1200-psi greater than the required compressive strength of concrete.
2. After sufficient experience and test data become available from the job, using ACI 214 methods of evaluation, the standard deviation may be reduced when the probable frequency of an average of three consecutive tests below required compressive strength will not exceed one in one hundred.

G. Adjustment to Concrete Mixes: Mix design adjustments may be requested by the Contractor when characteristics of materials, job conditions, weather, test results, or other circumstances warrant; at no additional cost to the City and as accepted by the Engineer. Laboratory test data for revised mix designs and strength results must be submitted to and accepted by the Engineer before using in the work.

H. Compressive Strength:

1. Design mixes for a specified strength of 3,500 psi at 28 days using a minimum of 5 1/4 bags of cement (94 pounds), and a maximum of 6 gallons of water per bag of cement, unless otherwise indicated.
2. Design mixes to provide concrete with the properties shown on the Drawings.

I. Admixtures:

1. Use air-entraining admixture in all concrete, unless otherwise shown or specified. Add air-entraining admixture at the manufacturer's prescribed rate to result in concrete at the point of placement having air content by volume within the following limits:
  - a. 6% to 9% for maximum aggregate 1/2 inch and under.
  - b. 4% to 6% for maximum aggregate over 1/2 inch through 1 1/2 inch.
  - c. 2.5% to 4.5% for maximum aggregate over 1 1/2 inch.

J. Slump Limits:

1. Proportion and design mixes to result in concrete slump at the point of placement as follows:
  - a. Ramps and Sloping Surfaces: Not more than 3 inches.
  - b. Reinforced Foundation Systems: Not less than 1 inch and not more than 3 inches.
  - c. All Other Concrete: Not less than 1 inch and not more than 4 inches.

## 1.05 TESTING DURING CONSTRUCTION

- A. All testing of samples will be done by a testing laboratory selected by the City in accordance with Section 01410. Testing shall be paid for separately by the City directly to the testing laboratory.
- B. Testing During Construction:
  1. Perform one slump test (ASTM C 143) for each concrete load at point of discharge, and prepare one set of three standard compressive strength cylinders (ASTM C 31) for each 50 cubic yards or fraction thereof of concrete placed in any one day. Store compressive strength cylinders in dampened protective material.
- C. The following quality control testing is required during construction:
  1. Sampling Fresh Concrete: ASTM C 172, except modified for slump to comply with ASTM C94.

2. Slump: ASTM C 143; one test for each concrete load at point of discharge; and one for each set of compressive strength test specimens; additional tests when concrete consistency seems to have changed.
- D. Compressive Strength:
1. ASTM C 39, one set of 6 standard cylinders (ASTM C 31) for each 50 cubic yards or fraction thereof, of each concrete class placed in any one day or for each 5,000 square feet of surface area placed; 2 specimens tested at 7 days, 3 specimens tested at 28 days, and one specimen retained in reserve for later testing if required.
  2. When the total quantity of a given class of concrete is less than 50 cubic yards, or the quantity of concrete or any single structure is less than 10 cubic yards, the Engineer may waive compressive strength testing, but such action shall not relieve the Contractor from responsibility for furnishing concrete of the required strength.
  3. The strength level of concrete will be considered satisfactory if the averages of all sets of three consecutive strength test results equal or exceed the specified strength and no individual strength test result falls below the specified strength by more than 500 psi.
- E. Air Content: ASTM C 231, pressure method or ASTM C 173; one for each set of compressive strength test specimens.
- F. Additional Tests: When test results indicate specified concrete strengths and other characteristics have not been attained, perform additional testing to determine the extent to which deficiencies exist. Where cored cylinders are utilized to determine adequacy of concrete, comply with ASTM C42.

## 1.06 SUBMITTALS

- A. Manufacturer's Data: For information only, submit manufacturer's specifications with application and installation instructions for proprietary materials and items, including reinforcement and forming accessories, admixtures, patching compounds, waterstops, joint systems, curing compounds and others as requested by the Engineer.
- B. Shop Drawings: Submit shop drawings for fabrication, bending, and placement of concrete reinforcement. Comply with the ACI Special Publication No. 66 (SP-66) "ACI Detailing Manual" showing bar schedules, stirrup spacing, diagrams of bent bars, and arrangements of concrete

reinforcement. Include special reinforcement required at openings through concrete structures.

- C. Laboratory Test Reports: Submit laboratory test reports for concrete materials and mix design test as specified.

## PART 2 – PRODUCTS

### 2.01 FORM MATERIALS

- A. Forms for Exposed Finish Concrete:
1. Unless otherwise shown or specified, construct all formwork for exposed concrete surfaces with plywood, metal, metal-framed plywood-faced or other acceptable panel-type materials, to provide continuous, straight, smooth, exposed surfaces. Furnish in largest practicable sizes to minimize number of joints and to conform to joint system shown on Drawings. Provide form material with sufficient thickness to withstand pressure of newly-placed concrete without bow or deflection.
  2. Where plywood is used in formwork, provide material complying with U.S. Product Standard PS-I "A-C or B-B High Density Overlaid Concrete Form", Class I, unless otherwise acceptable to Engineer.
- B. Forms for Unexposed Finish Concrete: Form concrete surfaces which will be unexposed in finished structure with plywood, lumber, metal or other acceptable material. Provide lumber dressed on at least two edges and one side for tight fit.
- C. Forms for Textured Finished Concrete: Form textured finish concrete surfaces with units of face design, size arrangement and configuration as shown on the Drawings. Provide solid backing and form supports to ensure stability of textured form liners.
- D. Cylindrical Columns and Supports: Form all round-section members with metal, fiberglass reinforced plastic, or paper or fiber tubes. Construct paper or fiber tubes of laminated plies using water-resistant type adhesive and wax-impregnated exterior for weather and moisture protection. Provide units with sufficient wall thickness to resist loads imposed by wet concrete without deformation.
- E. Curved Structures: Form round or curved surfaces to true arcs without flat planes unless otherwise indicated on the Drawings.

- F. Form Coatings: Provide commercial formulation form-coating compounds that will not bond with, stain nor adversely affect concrete surfaces, and will not impair subsequent treatments of concrete surfaces.

## 2.02 REINFORCING MATERIALS

- A. Reinforcing Bars: ASTM A 615, Grade 60 unless otherwise shown.
- B. Epoxy-Coated Reinforcing Bars: ASTM A 775.
- C. Steel Wire: ASTM A 82, plain, cold-drawn steel.
- D. Welded Wire Fabric: ASTM A 185, welded steel wire fabric.
- E. Supports for Reinforcement: Provide supports for reinforcement including bolsters, chairs, spacers and other devices for spacing, supporting and fastening reinforcing bars and welded wire fabric in place. Use wire bar type supports complying with CRSI recommendations, unless otherwise specified. Solid precast concrete block may be used for supporting footing and foundation mats against earth material. Wood, clay, brick and other non-standard devices will not be acceptable.
1. For slabs-on-grade, use supports with sand plates or horizontal runners where base materials will not support chair legs.
  2. For exposed-to-view concrete surfaces, where legs of supports are in contact with forms, provide supports with legs that are plastic protected or stainless steel protected.

## 2.03 CONCRETE MATERIALS

- A. Portland Cement:
1. ASTM C 150, Type I, unless otherwise acceptable to Engineer.
  2. Use only one brand of cement throughout the project, unless otherwise acceptable to Engineer.
- B. Aggregates: ASTM C 33, and as herein specified. Provide aggregates from a single source for all exposed concrete.
1. Fine Aggregate: Clean, sharp, natural sand free from loam, clay, lumps or other deleterious substances.

2. Coarse Aggregate: Clean, uncoated, crushed granite or similar hard stone processed from natural rock or stone, and containing no clay, mud, loam or foreign matter.
3. Maximum Aggregate Size: Not larger than one-fifth of the narrowest dimension between sides of forms, one-third of the depth of slabs, nor three-fourths of the minimum clear spacing between individual reinforcing bars or bundles of bars. Size limitations may be waived if, in the judgment of the Engineer, workability and methods of consolidation are such that concrete can be placed without honeycomb or voids.
4. Water: Clean, fresh, and safely drinkable by humans.
5. Air-Entraining Admixture: ASTM C 260.

## 2.04 RELATED MATERIALS

- A. Grout: Ready mixed Portland cement, sand and water mixture conforming with materials and mix design of highest strength project-required concrete except for deletion of coarse aggregate.
- B. Nonshrink Grout: Factory-premixed cementitious material containing no corrosive material, which is nonshrink from time of placement and shows no expansion after final set when tested under ASTM C 827, has an initial setting time of not less than 45 minutes, has a 24 hour compressive strength of not less than 3,000 psi under ASTM C 109 for a trowelable mix, and is selected and applied in conformance with manufacturer's recommendations.
- C. Compaction Grout:
  1. Compaction grouting of voids surrounding the exterior of sewers or manholes is accomplished with the constant placement of a stiff, mortar-type Portland cement based grout material at pressures not to exceed 100 psi at the pump, unless otherwise approved by the Engineer. Cement (if used) shall be Type I or Type II Portland Cement conforming to ASTM C150. Admixtures (if used) shall conform to ASTM C1017/C1017M, Standard Specification for Chemical Admixtures for Use in Producing Flowing Concrete. Grout shall either be ready-mix transported to the site, or mixed on-site. For each batch of ready-mix delivered to the site, the ready-mix plant shall issue a ticket recording the mix components, time mixed, water added, etc. The slump of the grout mix shall not exceed 3 inches.

2. The injected grout mass shall occupy the void space. The grout mass shall be injected at pressures which are requisite for the conditions encountered and shall not exceed 10 psi at the point of injection, unless otherwise approved by the Engineer. The grout volume shall expand and densify targeted soils in-place. The grout pressure produces soil compaction by displacing soil at depth until resisted by the weight of overlying soils. The grouting treatment is applied on a grid pattern, to accomplish improved compaction of displaced soils and greater uniformity of the treated soil mass.
  3. Provide positive displacement pumping units with variable speed capabilities. The pumping system shall be capable of pumping the grout at pressures up to 100 psi at the pump.
  4. Use steel injection pipes of sufficient diameter and wall thickness to allow grout injection to the pressure specified. Injection pipes may be installed from the interior of manholes. Otherwise, injection pipes shall be installed from the ground surface. The end of each injection pipe shall be sealed to prevent soil strata from entering the pipe during installation.
- D. Waterstops (Plastic): Provide flat, dumbbell type or centerbulb type waterstops at construction joints and other joints as indicated. Size to suit joints. Use polyvinyl chloride (PVC) waterstops complying with Corps of Engineers Spec. CRD-C572.
- E. Waterstops (Copper): Provide formed-sheet, annealed copper waterstops as shown.
- F. Joint Sealing Compound: One component, non-sag, low modulus polyurethane or polysulfide sealant conforming to Federal Specification TT-S230C, Class A, Type II and ASTM C920, Type S, Class 25, Grade NS.
- G. Moisture Barrier: Polyethylene sheet not less than 8 mils thick.
- H. Liquid Chemical Floor Hardener: Colorless aqueous solution containing a blend of magnesium fluosilicate and zinc fluosilicate combined with a wetting agent, containing not less than two pounds of fluosilicates per gallon.
- I. Absorptive Cover: Burlap cloth made from jute or kenaf, weighing approximately nine ounces per square yard, complying with AASHTO M182, Class 2.

- J. Moisture-Retaining Cover: One of the following, complying with ASTM C 171.
1. Waterproof Paper.
  2. Polyethylene Film.
  3. Polyethylene-coated burlap.
- K. Membrane-Forming Curing Compound: ASTM C 309, Type I unless other type acceptable to Engineer.

## 2.05 CONCRETE MIXING

A. Job-Site Mixing:

1. Mix materials for concrete in an acceptable drum type batch machine mixer. For mixers of one cubic yard, or smaller capacity, continue mixing at least 1 1/2 minutes, but not more than 5 minutes after all ingredients are in the mixer, before any part of the batch is released. For mixers of capacity larger than one cubic yard, increase the minimum 1 1/2 minutes of mixing time by 15 seconds for each additional cubic yard, or fraction thereof.
2. Provide a batch ticket for each batch discharged and used in the work, indicating the project identification name and number, date, mix time, quantity, and amount of water introduced.

B. Ready-Mix Concrete:

1. Comply with the requirements of ASTM C 94, and as herein specified.
2. Delete the references for allowing additional water to be added to the batch for material with insufficient slump. Addition of water to the batch will not be permitted.
3. During hot weather, or under conditions contributing to rapid setting of concrete, a shorter mixing time than specified in ASTM C 94 may be required.
4. When the air temperature is between 85F and 90F, reduce the mixing and delivery time from 1 1/2 hours to 75 minutes, and when the air temperature is above 90F, reduce the mixing and delivery time to 60 minutes.



## 2.06 FLOWABLE FILL

- A. Furnish and place flowable fill as directed by the Engineer. Applications include bedding, encasement and closures for pipe, and general backfill for trenches.
- B. All materials shall conform to the requirements of the Georgia Department of Transportation Specifications, current edition, Section 600 for controlled low strength flowable fill.
- C. The Contractor shall submit mix designs for flowable fill to the Engineer for approval.

## PART 3 – EXECUTION

### 3.01 FORMS

- A. Design, erect, support, brace and maintain:
  - 1. Design, erect, support, brace and maintain formwork to support vertical and lateral loads that might be applied until such loads can be supported by the concrete structure. Construct formwork so concrete members and structures are of correct size, shapes, alignment, elevation and position.
  - 2. Design formwork to be readily removable without impact, shock or damage to cast-in-place concrete surfaces and adjacent materials.
  - 3. Construct forms complying with ACI 347, to sizes, shapes, lines and dimensions shown, and to obtain accurate alignment, location, grades, level and plumb work in finished structures. Provide for openings, offsets, sinkages, keyways, recesses, moldings, rustications, reglets, chamfers, blocking, screeds, bulkheads, anchorages and inserts, and other features required in work. Use selected materials to obtain required finishes. Solidly butt joints and provide back-up at joints to prevent leakage of cement paste.
  - 4. Fabricate forms for easy removal without hammering or prying against the concrete surfaces. Provide crush plates or wrecking plates where stripping may damage cast concrete surfaces. Provide top forms for inclined surfaces where slope is too steep to place concrete with bottom forms only. Kerf wood inserts for forming keyways, reglets, recesses, and the like, to prevent swelling and for easy removal.

5. Provide temporary openings where interior area of formwork is inaccessible for cleanout, for inspection before concrete placement, and for placement of concrete. Securely brace temporary openings and set tightly to forms to prevent loss of concrete mortar. Locate temporary openings on forms at inconspicuous locations.
  6. Chamfer exposed corners and edges as shown, using wood, metal, PVC or rubber chamfer strips fabricated to produce uniform smooth lines and tight edge joints.
- B. Form Ties:
1. Factory-fabricated, adjustable-length, metal form ties, designed to prevent form deflection, to prevent spalling concrete surfaces upon removal, and to prevent passage of water along tie surface through concrete.
  2. Provide ties so portion remaining within concrete is at least 1 inch inside concrete, and do not leave holes larger than one-inch diameter in concrete surface.
- C. Provisions for Other Trades: Provide openings in concrete formwork to accommodate work of other trades. Determine size and location of openings, recesses and chases from trades providing such items. Accurately place and securely support items built into forms.
- D. Cleaning and Tightening: Thoroughly clean forms and adjacent surfaces to receive concrete. Remove chips, wood, sawdust, dirt or other debris just before concrete is placed. Retighten forms and bracing after concrete placement if required to eliminate mortar leaks and maintain proper alignment.

### 3.02 PLACING REINFORCEMENT

- A. Comply with the specified codes and standards, and Concrete Reinforcing Steel Institute's recommended practice for "Placing Reinforcing Bars", for details and methods of reinforcement placement and supports, and as herein specified.
- B. Clean reinforcement of loose rust and mill scale, earth, ice, and other materials that reduce or destroy bond with concrete.
- C. Accurately position, support and secure reinforcement against displacement by formwork, construction, or concrete placement operations. Locate and support reinforcing by metal chairs, runners, bolsters, spacers and hangers, as required.

- D. Place reinforcement to obtain at least the minimum coverages for concrete protection. Arrange, space and securely tie bars and bar supports to hold reinforcement in position during concrete placement operations. Set wire ties so ends are directed into concrete, not toward exposed concrete surfaces.
- E. Do not place reinforcing bars more than 2 inches beyond the last leg of continuous bar support. Do not use supports as bases for runways for concrete conveying equipment and similar construction loads.
- F. Install welded wire fabric in as long lengths as practicable. Lap adjoining pieces at least one full mesh and lace splices with wire. Offset end laps in adjacent widths to prevent continuous laps in either direction.

### 3.03 JOINTS

A. Construction Joints:

- 1. Locate and install necessary construction joints, which are not shown on the Drawings, so as not to impair the strength and appearance of the structure, as acceptable to the Engineer.
- 2. Provide keyways in all construction joints in walls, slabs and between walls and footings; accepted bulkheads designed for this purpose may be used for slabs. Construct keyways 1 1/2 inches deep unless otherwise detailed.
- 3. Place construction joints perpendicular to the main reinforcement. Continue all reinforcement across construction joints.

B. Waterstops: Provide waterstops in construction joints as indicated. Install waterstops to form a continuous diaphragm in each joint. Make provisions to support and protect waterstops during the progress of the work. Fabricate field joints in waterstops in accordance with manufacturer's printed instructions. Protect waterstop material from damage where it protrudes from any point.

C. Isolation Joints in Slabs-on-Ground: Construct isolation joints in slabs on ground at all points of contact between slabs on ground and vertical surfaces, such as column pedestals, foundation walls, grade beams and elsewhere as indicated.

D. Control Joints in Slabs-on-Ground:

1. Construct control joints in slabs-on-ground to form panels of patterns as shown. Use inserts 1/8 to 1/4 inch wide x 1/4 of the slab depth, unless otherwise shown.
2. Form control joints by inserting a premolded plastic, hardboard or fiberboard strip into the fresh concrete until the top surface of the strip is flush with the slab surface. Tool slab edges round on each side of insert. After the concrete has cured, remove inserts and clean groove of loose debris.

### 3.04 INSTALLATION OF EMBEDDED ITEMS

- A. General: Set and build into the work anchorage devices and other embedded items required for other work that is attached to, or supported by, cast-in-place concrete. Use setting drawings, diagrams, instructions and directions provided by suppliers of the items to be attached thereto.
- B. Edge Forms and Screed Strips for Slabs: Set edge forms or bulkheads and intermediate screed strips for slabs to obtain the required elevations and contours in the finished slab surface. Provide and secure units sufficiently strong to support the types of screeds required. Align the concrete surface to the elevation of the screed strips by the use of strike-off templates or accepted compacting type screeds.

### 3.05 PREPARATION OF FORM SURFACES

- A. Clean re-used forms of concrete matrix residue, repair, and patch as required to return forms to acceptable surface condition. Coat the contact surfaces of forms with a form-coating compound before reinforcement is placed.
- B. Thin form-coating compounds only with thinning agent of type, and in amount, and under conditions of the form-coating compound manufacturer's directions. Do not allow excess form-coating material to accumulate in the forms or to come into contact with concrete surfaces against which fresh concrete will be placed. Apply in compliance with manufacturer's instructions.
- C. Coat steel forms with a non-staining, rust-preventative form oil or otherwise protect against rusting. Rust-stained steel formwork is not acceptable.

### 3.06 CONCRETE PLACEMENT

#### A. Pre-Placement Inspection:

1. Before placing concrete, inspect and complete the formwork installation, reinforcing steel, and items to be embedded or cast-in. Notify other crafts to permit the installation of their work; cooperate with other trades in setting such work, as required. Moisten wood forms immediately before placing concrete, where form coatings are not used.
2. Coordinate the installation of joint materials and moisture barriers with placement of forms and reinforcing steel.

#### B. Construction Sequence: Before placing any concrete, complete blasting, heavy earthwork and other construction operations that might cause damage to concrete structures.

##### 1. General:

- a. Comply with ACI 304, and as herein specified.
- b. Deposit concrete continuously or in layers of such thickness that no concrete will be placed on concrete which has hardened sufficiently to cause the formation of seams or planes of weakness within the section. If a section cannot be placed continuously, provide construction joints as herein specified. Deposit concrete as nearly as practicable to its final location to avoid segregation due to rehandling or flowing.
- c. At all horizontal waterstops, place 1/2 inch of grout for each foot of wall pour height in bottom of forms immediately before pouring concrete walls.

##### 2. Placing Concrete in Forms:

- a. Deposit concrete in forms in horizontal layers not deeper than 24 inches and in a manner to avoid inclined construction joints. Where placement consists of several layers, place each layer while preceding layer is still plastic to avoid cold joints.
- b. Consolidate placed concrete by mechanical vibrating equipment supplemented by hand spading, rodding, or tamping. Use equipment and procedures for consolidation

of concrete in accordance with ACI 309 recommended practices.

- c. Do not use vibrators to transport concrete inside of forms. Insert and withdraw vibrators vertically at uniformly spaced locations not farther than the visible effectiveness of the machine. Place vibrators to rapidly penetrate the placed layer of concrete and at least 6 inches into the preceding layer. Do not insert vibrators into lower layers of concrete that have begun to set. At each insertion limit the duration of vibration to the time necessary to consolidate the concrete and complete embedment of reinforcement and other embedded items without causing segregation of the mix.

3. Placing Concrete Slabs:

- a. Deposit and consolidate concrete in a continuous operation, within the limits of construction joints, until the placing of a panel or section is completed.
- b. Consolidate concrete during placing operations so that concrete is thoroughly worked around reinforcement and other embedded items and into corners.
- c. Bring slab surfaces to the correct level with a straightedge and strikeoff. Use bull floats or darbies to smooth the surface, leaving it free of humps or hollows. Do not disturb the slab surfaces prior to beginning finishing operations.
- d. Maintain reinforcing in the proper position during concrete placement operations.

4. Cold Weather Placing:

- a. Protect concrete work from physical damage or reduced strength that could be caused by frost, freezing actions, or low temperatures, in compliance with ACI 306R and as herein specified.
- b. When air temperature has fallen to or is expected to fall below 40F, uniformly heat all water and aggregates before mixing to obtain a concrete mixture temperature of not less than 50F, and not more than 80F at point of placement.

- c. Do not use frozen materials or materials containing ice or snow. Do not place concrete on frozen subgrade or on subgrade containing frozen materials.
- d. Do not use calcium chloride, salt and other materials containing antifreeze agents or chemical accelerators, unless otherwise accepted in writing by the Engineer.

5. Hot Weather Placing:

- a. When hot weather conditions exist that would seriously impair the quality and strength of concrete, place concrete in compliance with ACI 305R and as herein specified.
- b. Cool ingredients before mixing to maintain concrete temperature at time of placement below 90F. Mixing water may be chilled, or chopped ice may be used to control the concrete temperature, provided the water equivalent of the ice is calculated to the total amount of mixing water.
- c. Cover reinforcing steel with water-soaked burlap if it becomes too hot, so that the steel temperature will not exceed the ambient air temperature immediately before embedment in concrete.
- d. Fog spray forms, reinforcing steel and subgrade just before concrete is placed.
- e. Do not use retarding admixtures without the written acceptance of the Engineer.

### 3.07 FINISH OF FORMED SURFACES

- A. Concealed Surfaces: For formed concrete surfaces not exposed-to-view in the finished work, leave surface finish imparted by the form facing material used, with defective areas and form tie voids repaired and patched as specified, and fins and other projections exceeding 1/4 inch in height rubbed flush.
- B. Visible Surfaces: For formed concrete surfaces exposed-to-view, including those surfaces of water or other material holding structures visible when the structure is empty, or surfaces that are to be covered with a thin or flexible finish material bonded to the concrete, perform finish operations as specified above under "Concealed Surfaces," and in addition wet and rub entire surfaces with a carborundum stone of medium fineness until all form marks and other surface irregularities have been removed and a uniform

surface appearance achieved. Do not create a plaster coating on concrete.

- C. Unformed Visible Surfaces: At tops of walls, horizontal offsets and similar unformed surfaces occurring adjacent to formed surfaces, strike-off smooth and finish with a texture matching adjacent formed surfaces. Continue final surface treatment of formed surfaces uniformly across adjacent unformed surfaces.

### 3.08 MONOLITHIC SLAB FINISHES

A. Scratch Finish:

1. Apply scratch finish to monolithic slab surfaces that are to receive concrete floor topping or mortar setting beds for tile, Portland cement terrazzo, and other bonded applied cementitious finish flooring material, and as otherwise indicated.
2. After placing slabs, plane surface so that depressions between high spots do not exceed 1/2 inch under a 10-foot straightedge. Slope surfaces uniformly to drains where required. After leveling, roughen surface before final set, with stiff brushes, brooms or rakes.

B. Float Finish:

1. Apply float finish to monolithic slab surfaces that are to receive trowel finish and other finishes as hereinafter specified, and slab surfaces which are to be covered with membrane or elastic waterproofing, membrane or elastic roofing, or sand-bed terrazzo, and as otherwise indicated.
2. After screeding, consolidating and leveling concrete slabs, do not work surface until ready for floating. Begin floating when surface water has disappeared or when concrete has stiffened sufficiently to permit operation of floats. Consolidate surface with power-driven floats, or by hand-floating if area is small or inaccessible to power units. Check and level surface plane so that depressions between high spots do not exceed 6/16 inch under a 10 foot straightedge. Cut down high spots and fill low spots. Uniformly slope surfaces to drains. Immediately after leveling, refloat surface to a uniform, smooth, granular texture.

C. Trowel Finish:



1. Apply trowel finish to monolithic slab surfaces that are to be exposed-to-view, unless otherwise shown, and slab surfaces that are to be covered with resilient flooring, carpet, ceramic or quarry tile, paint or other thinfilm finish coating system.
2. After floating, begin first trowel finish operation using a power-driven trowel. Begin final troweling when surface produces a ringing sound as trowel is moved over surface. Consolidate concrete surface by final hand-troweling operation, free of trowel marks, uniform in texture and appearance, and with a level surface plane so that depressions between high spots do not exceed 1/8 inch under a 10 foot straightedge. Grind smooth surface defects that would telegraph through applied floor covering system.

D. Chemical-Hardener Finish:

1. Apply chemical-hardener finish to interior concrete floors where indicated. Apply liquid chemical-hardener after complete curing and drying of the concrete surface. Dilute liquid hardener with water, and apply in three coats; first coat, 1/3 strength; second coat, 1/2 strength; third coat, 2/3 strength. Evenly apply each coat, and allow 24 hours for drying between coats.
2. Apply proprietary chemical hardeners, in accordance with manufacturer's printed instructions.
3. After final coat of chemical-hardener solution is applied and dried, remove surplus hardener by scrubbing and mopping with water.

E. Non-Slip Broom Finish:

1. Apply non-slip broom finish to exterior concrete platforms, steps and ramps, and elsewhere as indicated.
2. Immediately after trowel finishing, slightly roughen concrete surface by brooming with fiber bristle broom perpendicular to main traffic route. Coordinate required final finish with the Engineer before application.

F. Trowel and Fine Broom Finish: Where ceramic or quarry tile is to be installed with thin-set mortar, apply trowel finish as specified, then immediately follow with slightly scarifying surface by fine brooming.

### 3.09 CONCRETE CURING AND PROTECTION

#### A. General:

1. Protect freshly placed concrete from premature drying, and excessive cold or hot temperature, and maintain without drying at a relatively constant temperature for a period of time necessary for hydration of cement and proper hardening.
2. Start initial curing as soon as free water has disappeared from concrete surface after placing and finishing. Weather permitting, keep continuously moist for not less than 7 days.
3. Begin final curing procedures immediately following initial curing and before concrete has dried. Continue final curing for at least seven days and in accordance with ACI 30I procedures. Avoid rapid drying at end of final curing period.

#### B. Curing Methods: Perform curing of concrete by one or more of the following methods as selected by the Contractor:

1. Provide moist curing: by covering concrete surfaces with specified absorptive cover, thoroughly saturating cover with water and keeping continuously wet. Place absorptive cover to provide coverage of concrete surfaces and edges, with 4 inch lap over adjacent absorptive cover.
2. Provide moisture-cover curing: by covering concrete surfaces with moisture-retaining cover, placed in widest practicable width with sides and ends lapped at least 3 inches and sealed by waterproof tape or adhesive. Immediately repair any holes or tears during curing period using cover material and waterproof tape.
3. Provide membrane curing: by applying compound to damp concrete surfaces as soon as film has disappeared. Apply uniformly in continuous operation by power-spray or roller equipment in accordance with manufacturer's directions. Recoat areas that are subjected to heavy rainfall within three hours after initial application. Maintain continuity of coating and repair damage during curing period.
4. Do not use membrane curing compounds on surfaces which are to be covered with a coating material applied directly to concrete or with a covering material bonded to concrete, such as other concrete, liquid floor hardener, waterproofing, dampproofing,

membrane roofing, flooring, painting, and other coatings and finish materials, unless otherwise acceptable to the Engineer.

- C. Curing Formed Surfaces: Cure formed concrete surfaces, including undersides of beams, supported slabs and other similar surfaces by moist curing with forms in place for full curing period or until forms are removed. If forms are removed, continue curing by methods specified above, as applicable.
- D. Curing Unformed Surfaces: Initially cure unformed surfaces, such as slabs, floor topping, and other flat surfaces by moist curing. Final cure unformed surfaces, unless otherwise specified, by methods specified above, as applicable.

### 3.10 FORM REMOVAL

- A. In all cases, time and sequence of concrete form removal is at Contractor discretion. Formwork supporting weight of concrete, such as beams and slabs, must remain in place at least 14 days and until concrete has attained minimum design 28 day compressive strength. Formwork not supporting weight of concrete, such as sides of beams, walls and columns, may be removed no sooner than 48 hours after placement of concrete or when concrete is sufficiently hard as not to be damaged by form removal operations.

### 3.11 RE-USE OF FORMS

- A. Clean and repair surfaces of forms to be re-used in the work. Split, frayed, delaminated or otherwise damaged form facing material will not be acceptable. Apply new form coating compound as specified for new formwork.
- B. When forms are extended for successive concrete placement, thoroughly clean surfaces, remove fins and laitance, and tighten forms to close joints. Align and secure joints to avoid offsets. Do not use "patched" forms for exposed concrete surfaces, except as acceptable to Engineer.

### 3.12 MISCELLANEOUS CONCRETE ITEMS

- A. Filling-In: Fill-in holes and openings left in concrete structures for passage of work by other trades, unless otherwise shown or directed, after work of other trades is in place. Mix, place and cure concrete as herein specified, to blend with in-place construction. Provide other miscellaneous concrete filling shown or required to complete work.

- B. Curbs: Provide monolithic finish to interior curbs by stripping forms while concrete is still green and steel-troweling surfaces to a hard, dense finish with corners, intersections and terminations slightly rounded.
- C. Equipment Bases and Foundations: Provide machine and equipment bases and foundations, as shown on Drawings. Set anchor bolts for machines and equipment to template at correct elevations, complying with certified diagrams or templates of manufacturer furnishing machines and equipment. Grout base plates and foundations as indicated, using specified non-shrink grout. Use non-metallic grout for exposed conditions, unless otherwise indicated.
- D. Steel Pan Stairs: Provide concrete fill for steel pan stair treads and landings and associated items. Cast-in safety inserts and accessories as shown on Drawings. Screed, tamp, and finish concrete surfaces as scheduled.
- E. Reinforced Masonry: Provide concrete grout for reinforced masonry lintels and bond beams where indicated on Drawings and as scheduled. Maintain accurate location of reinforcing steel during concrete placement.
- F. Compaction Grouting: The Contractor shall confirm the Engineer's approximate location of void areas around the suspect sewer or manhole prior to installation of the injection pipes. All costs associated with the void investigation shall be incidental to the compaction grouting work. If necessary, the grouting operation shall be delayed until the Contractor can perform point repairs or other rehabilitative measures to restore structural stability to the sewer. The grout injection rate shall not exceed 4.0 cubic feet per minute, unless authorized by the Engineer. Progress the grouting process in stages using the "bottom up" method. The "bottom up" method stages start at the bottom of the grouting pipe, at least 1 foot into the underlying dense soil strata, progressing upward at maximum intervals of 2 feet. The Contractor shall carefully control grout pumping rates and injection pressures. Injection holes lost during grouting operations shall be replaced by the Contractor at no additional cost to the Owner. For injection pipes installed from the interior of manholes, remove the injectors and patch the holes with quick setting hydraulic cement.

### 3.13 FLOWABLE FILL

- A. Furnish and place flowable fill concrete as directed by the Engineer. Typical applications include bedding, encasement and closures for pipe and general backfill of trenches.
- B. Contractor shall flood the pipeline, sequence Flowable Fill placement, provide straps, soil anchors or other approved means of restraint to

prevent flotation or misalignment that may occur at no additional cost to the City.

- C. Flowable fill shall be protected from freezing for a period of 36 hours after placement.
- D. All flowable fill shall be furnished and installed in accordance with Georgia Department of Transportation Standard Specification Section 600 – Controlled Low Strength Flowable Fill and/or City of Atlanta Department of Public Works flowable fill requirements whichever is deemed appropriate by the Engineer.

### 3.14 CONCRETE SURFACE REPAIRS

#### A. Patching Defective Areas:

- 1. Repair and patch defective areas with cement mortar immediately after removal of forms, but only when acceptable to Engineer.
- 2. Cut out honeycomb, rock pockets, voids over 1/8 inch in any dimension and holes left by tie rods and bolts, down to solid concrete but, in no case to a depth of less than one inch. Make edges of cuts perpendicular to the concrete surface. Thoroughly clean, dampen with water and brush-coat the area to be patched with neat cement grout. Proprietary patching compounds may be used when acceptable to Engineer.
- 3. For exposed-to-view surfaces, blend white Portland cement and standard Portland cement so that, when dry, patching mortar will match color of surrounding surface. Provide test areas at inconspicuous location to verify mixture and color match before proceeding with patching. Compact mortar in place and strike-off slightly higher than surrounding surface.

#### B. Repair of Formed Surfaces:

- 1. Remove and replace concrete having defective surfaces if defects cannot be repaired to satisfaction of Engineer. Surface defects, as such, include color and texture irregularities, cracks, spalls, air bubbles, honeycomb, rock pockets and holes left by tie rods and bolts; fins and other projections on surface; and stains and other discolorations that cannot be removed by cleaning. Flush out form tie holes, fill with dry pack mortar, or precast cement core plugs secured in place with bonding agent.

2. Repair concealed formed surfaces, where possible, that contain defects that adversely affect the durability of the concrete. If defects cannot be repaired, remove and replace the concrete.

C. Repair of Unformed Surfaces:

1. Test unformed surfaces, such as monolithic slabs, for smoothness and to verify surface plane to tolerances specified for each surface and finish. Correct low and high areas as herein specified. Test unformed surfaces sloped to drain for trueness of slope, in addition to smoothness, using a template having required slope.
2. Repair finished unformed surfaces that contain defects that adversely affect durability of concrete. Surface defects, as such, include crazing, cracks in excess of 0.01 inch wide or which penetrate to reinforcement or completely through non-reinforced sections regardless of width, spalling, pop-outs, honeycomb, rock pockets, and other objectionable conditions.
3. Correct high areas in unformed surfaces by grinding, after concrete has cured at least 14 days.
4. Correct low areas in unformed surfaces during, or immediately after completion of surface finishing operations by cutting out low areas and replacing with fresh concrete. Finish repaired areas to blend into adjacent concrete. Proprietary patching compounds may be used when acceptable to the Engineer.
5. Repair defective areas, except random cracks and single holes not exceeding one-inch diameter, by cutting out and replacing with fresh concrete. Remove defective areas to sound concrete with clean, square cuts and expose reinforcing steel with at least 3/4 inch clearance all around. Dampen concrete surfaces in contact with patching concrete, and brush with a neat cement grout coating or concrete bonding agent. Place patching concrete before grout takes its initial set. Mix patching concrete of same materials to provide concrete of the same type or class as original concrete. Place, compact and finish to blend with adjacent finished concrete. Cure in the same manner as adjacent concrete.
6. Repair isolated random cracks and single holes not over one inch in diameter by dry-pack method. Groove top of cracks and cutout holes to sound concrete and clean of dust, dirt and loose particles. Dampen cleaned concrete surfaces and brush with neat cement grout coating or concrete bonding agent. Place dry-pack before cement grout takes its initial set. Mix dry-pack, consisting of one

part Portland cement to 2 1/2 parts fine aggregate passing a No. 16 mesh sieve, using only enough water as required for handling and placing. Compact dry-pack mixture in place and finish to match adjacent concrete. Keep patched areas continuously moist for not less than 72 hours.

7. Repair methods not specified above may be used, subject to acceptance of Engineer.
8. Agreement by the Engineer to permit repair or patching of concrete does not waive the Engineer's authority to require complete removal and replacement of defective concrete pours should the patch not prove satisfactory to the Engineer, due either to deficiency in strength, function or appearance.

END OF SECTION